

Thick Film, Resistor Array

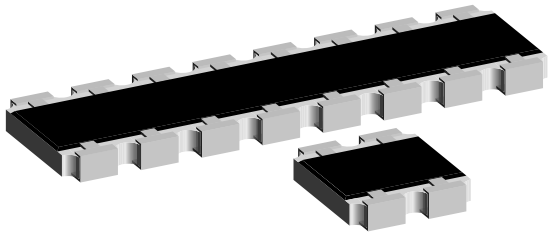

FEATURES

- Convex terminal array available with either scalloped corners (E version) or square corners (S version)
- 4, 8, 10, or 16 terminal package with either isolated resistors or bussed resistors
- Single component reduces board space and component counts
- Automatic placement capability
- Wave and solder paste reflow compatible
- Thick film resistance element
- Solderable wrap around termination
- Nickel barrier for inner electrode protection
- Standard E-24 ($\pm 2\%$ and $\pm 5\%$) and E-96 ($\pm 1\%$) resistance values
- Operating temperature range of -55°C to $+150^{\circ}\text{C}$
- Consult factory for additional schematics, values, etc

STANDARD ELECTRICAL SPECIFICATIONS

MODEL	POWER RATING $P_{70^{\circ}\text{C}}$ W	CIRCUIT	LIMITING ELEMENT VOLTAGE MAX V_{\cong}	TEMPERATURE COEFFICIENT ppm/ $^{\circ}\text{C}$	TOLERANCE %	RESISTANCE RANGE Ω	E-SERIES
CRA12E & S	0.100	01, 02, 20	50	200	2, 5	10R – 1M Ω	24
	0.125	03		100	1	10R – 1M Ω	24 – 96
				Jumper: Zero Ohm Resistor on Request			

- Power rating depends on the max. temperature at the solder point, the component placement density and the substrate material
- Operating temperature Range: -55°C to $+150^{\circ}\text{C}$
- Ask about further value ranges
- Packaging: according to EIA 481
- 100ppm TC is standard with 1% values and 200ppm TC is standard for 5% values

TECHNICAL SPECIFICATIONS

PARAMETER	UNIT	CRA12E & S 01 / 02 / 20 CIRCUIT	CRA12E & S 03 CIRCUIT
Rated Dissipation at 70°C	W	0.1	0.125
Limiting Element Voltage ¹⁾	V_{\cong}	50	
Insulation Voltage (1min)	$V_{\text{dc/ac peak}}$	100	
Category Temperature Range	$^{\circ}\text{C}$	$-55 / +150$	
Insulation Resistance	Ω	$> 10^9$	

¹⁾Rated voltage: $\sqrt{P \times R}$

ORDERING INFORMATION

CRA12E	04	01	105	G	RB8
MODEL	TERMINAL COUNT	CIRCUIT TYPE	R-VALUE Ω	TOLERANCE $\pm\%$	PACKAGING
CRA12E	04, 08, 10, 16	01, 02, 03, 20	First two digits (three for 1%)	F = $\pm 1\%$	Paper tape 2000pcs
CRA12S	08, 10	01, 02, 03, 20	are significant. Last digit is the multiplier	G = $\pm 2\%$	
				J = $\pm 5\%$ Z = 0 Ω Jumper	

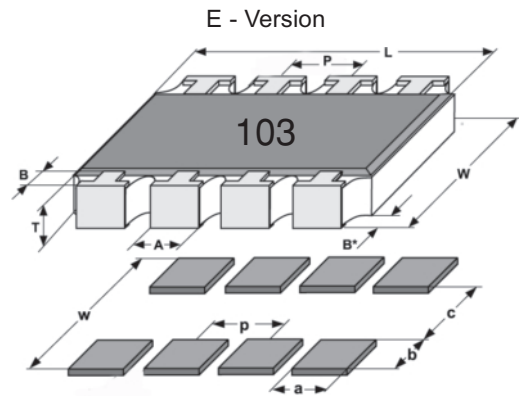
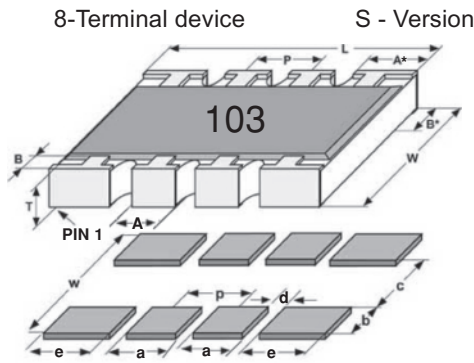

MODEL	PIN NO#	DIMENSIONS [in millimetres]							
		L	A	A*	B	B*	P	T	W
12E	4	2.54	0.79	-	0.51	0.38	1.27	0.53	3.05
12E	8	5.08	0.79	-	0.51	0.38	1.27	0.53	3.05
12S	8	5.08	0.79	0.89	0.51	0.38	1.27	0.53	3.05
12E	10	6.40	0.79	-	0.51	0.38	1.27	0.53	3.05
12S	10	6.40	0.79	0.89	0.51	0.38	1.27	0.53	3.05
12E	16	10.30	0.79	-	0.51	0.38	1.27	0.53	3.05
	Tol	-0.15	-0.15	-0.15	-0.25	-0.2	-0.1	-0.1	-0.15

	SOLDER PAD DIMENSIONS [in millimetres]						
	c	w	d	p	a	b	e
WAVE	2.2	4.3	0.57	1.27	0.71	1.05	1.09
REFLOW	2.2	3.9	0.57	1.27	0.71	0.86	1.09

The dimensions shown are for 8 pin part. For parts with different pin numbers use the same pitch and add or subtract pads as required.

CIRCUIT SCHEMATICS

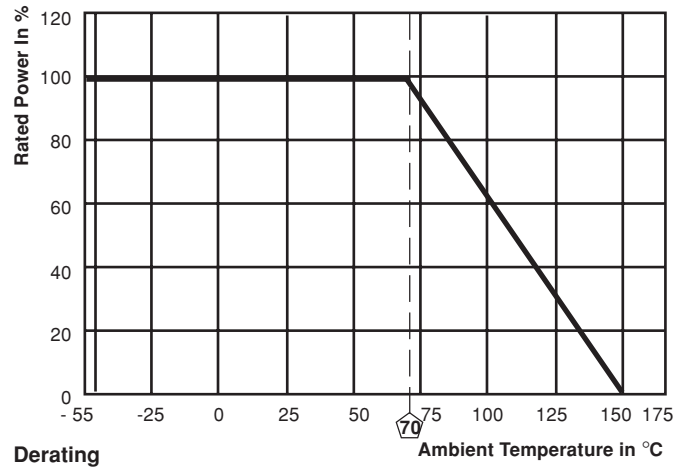
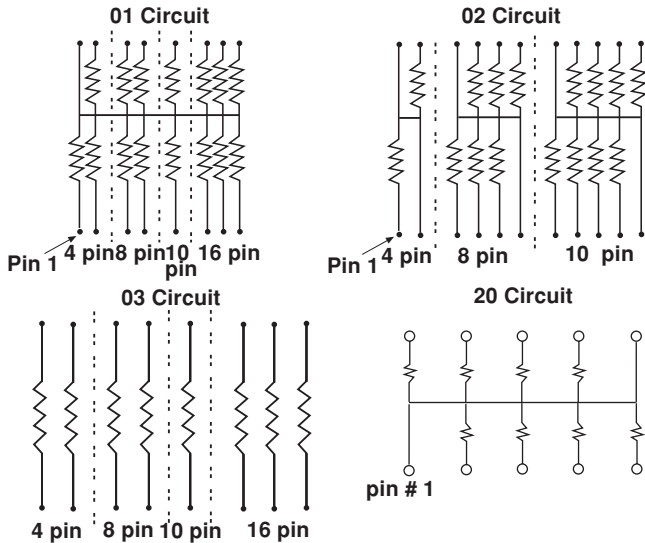

PERFORMANCE		
TEST	CONDITIONS OF TEST	TEST RESULTS
Endurance Test at 70°C per EIA 575-3.14	1000 hours at 70°C, 1.5 hours "ON", 0.5 hours "OFF"	± 1.0%
Overload per EIA 575-3.6	Short time overload 2.5 x rated continuous working voltage for 5 seconds. Not to exceed 2 x max operating voltage	± 0.5%
Thermal Shock	per EIA 575-3.5	± 0.5%
Moisture Resistance	per EIA 575-3.10	± 1.0%
Resistance to Soldering Heat EIA 575-3.8	10 seconds at 260°C solder bath temperature	± 2.0%
High Temperature Exposure	per EIA 575-3.7	± 1.0%
Low Temperature Operations	per EIA 575-3.6	± 0.5%
Solderability & Leaching	EIA 575-3.12	95% Coverage