

Resin-Molded, Radial-Lead Solid Tantalum Capacitors

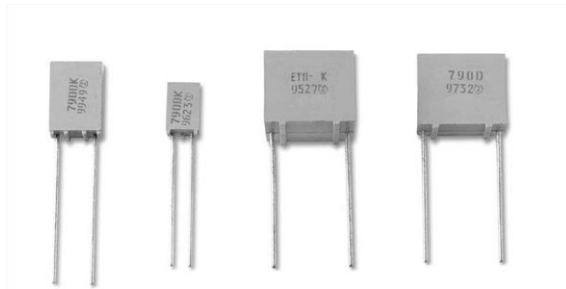

FEATURES

- Terminations: Tin/lead (SnPb), 100 % tin (Sn)
- Four case sizes precisely molded with a flame retardant epoxy resin
- Stand off on all case sizes
- Available on tape for automatic insertion equipment (only A- and B-case, C- and D-case on request)
- Low leakage current
- Low impedance
- Extended value ranges available
- Compliant to RoHS directive 2002/95/EC



RoHS*
COMPLIANT

PERFORMANCE CHARACTERISTICS

Operating Temperature: - 55 °C to + 125 °C

ORDERING INFORMATION							
790D	157	X0	006	R	2	P	E3
MODEL	CAPACITANCE	CAPACITANCE TOLERANCE	DC VOLTAGE RATING	CASE CODE	STYLE NUMBER	PACKAGING	ROHS COMPLIANT
790D = Standard and extended range	Expressed in picofarads. The first two digits are the significant figures. The third is the number of zeros following.	X0 = ± 20 % X9 = ± 10 %	Expressed in volts. To complete the three-digit block, zeros precede the voltage rating. A decimal point is indicated by an "R" (6R3 = 6.3 V)	See ratings and case codes table	Insulated case (standard)	See taping specification B : Bulk G : Ammopack H = 16.5 mm H : Ammopack H = 18.5 mm I : Ammopack shouldered Leads (A case) X : Reel Pack H = 16.5 mm Y : Reel Pack H = 18.5 mm Z : Reel pack shouldered Leads (A case)	E3 = 100 % tin termination (RoHS compliant) Blank = SnPb termination

DIMENSIONS in millimeters

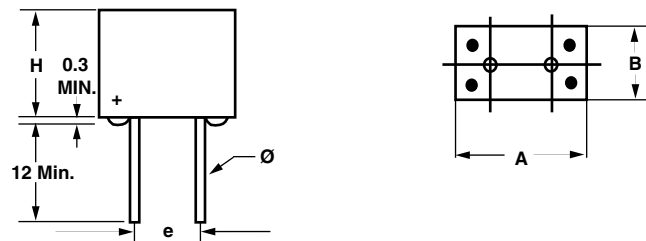

CASE CODE	H MAX. (mm)	A MAX. (mm)	B MAX. (mm)	E ± 0.15 (mm)	Ø 0.05 (+ 10 %) (mm)
A	7.3	4.7	4.2	2.54	0.5
B	10.5	7.3	4.8	5.08	0.5
C	10.5	12.3	7.3	10.16	0.6
D	10.5	12.3	12.3	10.16	0.6

PACKAGING QUANTITIES

CASE CODE	REEL X/Y	AMMO G/H	BULK B
A	1000	1000	500
B	1000	1000	250
C	300 ⁽¹⁾	300 ⁽¹⁾	100
D	200 ⁽¹⁾	200 ⁽¹⁾	50

Note

⁽¹⁾ Non preferred configuration on request only

* Pb containing terminations are not RoHS compliant, exemptions may apply



RATINGS AND CASE CODES																
C _R μF	RATED VOLTAGE U _R AT + 85 °C															
	6.3 V		10 V		16 V		20 V		25 V		35 V		40 V		50 V	
	CATEGORY VOLTAGE U _C AT + 125 °C															
	4.0 V		6.3 V		10 V		13 V		16 V		23 V		25 V		32 V	
	Std.	Ext.	Std.	Ext.	Std.	Ext.	Std.	Ext.	Std.	Ext.	Std.	Ext.	Std.	Ext.	Std.	Ext.
0.10														A		A
0.15																A
0.22																A
0.33														A		
0.47														A		
0.68																A
1.0														A		
1.5									A					B		A
2.2					A		A							B		B
3.3					A								A	B		B
4.7			A							A				B		B
6.8	A							A						B		B
10						A			B				B	C		C
15				A	B		B			B				C		C
22		A			B			B		B				C		C
33			B			B			C				C			
47	B			B	C			C								
68		B		B	C			C								
100			C		D	C	D									
150	C			C												
220		C	D													
330	D															

STANDARD/EXTENDED RATINGS					
CAPACITANCE C_R (μ F)	CASE CODE	PART NUMBER	MAX. DCL AT + 25 °C (μ A)	MAX. DF 120 Hz, AT + 25 °C (%)	MAX. IMPEDANCE 100 kHz, AT + 25 °C (Ω)
$U_R = 6.3$ V AT + 85 °C, SURGE = 8 V . . . $U_C = 4$ V AT + 125 °C, SURGE = 5 V					
6.8	A	790D685X(*)6R3A2(#)	1.0	6	4.0
22	A	790D226X(*)6R3A2(#)	1.3	6	2.1
47	B	790D476X(*)6R3B2(#)	2.9	6	1.3
68	B	790D686X(*)6R3B2(#)	4.2	6	1.3
150	C	790D157X(*)6R3C2(#)	9.4	6	0.6
220	C	790D227X(*)6R3C2(#)	13.8	6	0.6
330	D	790D337X(*)6R3D2(#)	20.7	8	0.4
$U_R = 10$ V AT + 85 °C, SURGE = 13 V . . . $U_C = 6.3$ V AT + 125 °C, SURGE = 8 V					
4.7	A	790D475X(*)010A2(#)	1.0	6	4.0
15	A	790D156X(*)010A2(#)	1.5	6	2.5
33	B	790D336X(*)010B2(#)	3.3	6	1.3
47	B	790D476X(*)010B2(#)	4.7	6	1.4
68	B	790D686X(*)010B2(#)	6.8	6	1.3
100	C	790D107X(*)010C2(#)	10.0	6	0.6
150	C	790D157X(*)010C2(#)	15.0	6	0.6
220	D	790D227X(*)010D2(#)	22.0	8	0.4
$U_R = 16$ V AT + 85 °C, SURGE = 20 V . . . $U_C = 10$ V AT + 125 °C, SURGE = 13 V					
2.2	A	790D225X(*)016A2(#)	1.0	6	5.5
3.3	A	790D335X(*)016A2(#)	1.0	6	4.4
10	A	790D106X(*)016A2(#)	1.6	6	2.7
15	B	790D156X(*)016B2(#)	2.4	6	1.6
22	B	790D226X(*)016B2(#)	3.5	6	1.3
33	B	790D336X(*)016B2(#)	5.2	6	1.6
47	C	790D476X(*)016C2(#)	7.5	6	0.8
68	C	790D686X(*)016C2(#)	10.8	6	0.6
100	C	790D107X(*)016C2(#)	16.0	6	0.7
100	D	790D107X(*)016D2(#)	16.0	6	0.5
$U_R = 20$ V AT + 85 °C, SURGE = 26 V . . . $U_C = 13$ V AT + 125 °C, SURGE = 16 V					
2.2	A	790D225X(*)020A2(#)	1.0	6	5.5
6.8	A	790D685X(*)020A2(#)	1.3	6	3.5
15	B	790D156X(*)020B2(#)	3.0	6	1.5
22	B	790D226X(*)020B2(#)	4.4	6	2.1
47	C	790D476X(*)020C2(#)	9.4	6	0.7
68	C	790D686X(*)020C2(#)	13.6	6	0.8
100	D	790D107X(*)020C2(#)	20.0	6	0.7

Note

- Extended Ratings in bold print
- (*) Insert 0 for ± 20 % tolerance or 9 for ± 10 %
- (#) See order information, packaging code



Resin-Molded, Radial-Lead
Solid Tantalum Capacitors

Vishay Sprague

STANDARD/EXTENDED RATINGS					
CAPACITANCE C _R (μF)	CASE CODE	PART NUMBER	MAX. DCL AT + 25 °C (μA)	MAX. DF 120 Hz, AT + 25 °C (%)	MAX. IMPEDANCE 100 kHz, AT + 25 °C (Ω)
U_R = 25 V AT + 85 °C, SURGE = 32 V . . . U_C = 16 V AT + 125 °C, SURGE = 20 V					
1.5	A	790D155X(*)025A2(#)	1.0	6	6.0
4.7	A	790D475X(*)025A2(#)	1.1	6	4.5
10	B	790D106X(*)025B2(#)	2.5	6	1.6
15	B	790D156X(*)025B2(#)	3.7	6	2.4
22	B	790D226X(*)025B2(#)	5.5	6	2.1
33	C	790D336X(*)025C2(#)	8.2	6	0.8
U_R = 35 V AT + 85 °C, SURGE = 45 V . . . U_C = 23 V AT + 125°C, SURGE = 29 V					
3.3	A	790D335X(*)035A2(#)	1.2	6	6.0
10	B	790D106X(*)035B2(#)	3.5	6	2.6
33	C	790D336X(*)035C2(#)	11.6	6	1.3
U_R = 40 V AT + 85 °C, SURGE = 52 V . . . U_C = 25 V AT + 125 °C, SURGE = 32 V					
0.10	A	790D104X(*)040A2(#)	1.0	6	30
0.33	A	790D334X(*)040A2(#)	1.0	6	14
0.47	A	790D474X(*)040A2(#)	1.0	6	11
1.0	A	790D105X(*)040A2(#)	1.0	6	6.5
1.5	B	790D155X(*)040B2(#)	1.0	6	5.2
2.2	B	790D225X(*)040B2(#)	1.0	6	4.0
3.3	B	790D335X(*)040B2(#)	1.3	6	2.8
4.7	B	790D475X(*)040B2(#)	1.8	6	2.0
6.8	B	790D685X(*)040B2(#)	2.7	6	1.6
10	C	790D106X(*)040C2(#)	4.0	6	1.3
15	C	790D156X(*)040C2(#)	6.0	6	1.0
22	C	790D226X(*)040C2(#)	8.8	6	0.8
U_R = 50 V AT + 85 °C, SURGE = 65 V . . . U_C = 32 V AT + 125 °C, SURGE = 41 V					
0.10	A	790D104X(*)050A2(#)	1.0	6	30
0.15	A	790D154X(*)050A2(#)	1.0	6	24
0.22	A	790D224X(*)050A2(#)	1.0	6	18
0.68	A	790D684X(*)050A2(#)	1.0	6	8.0
1.0	A	790D105X(*)050A2(#)	1.0	6	6.5
1.5	B	790D155X(*)050B2(#)	1.0	6	5.2
2.2	B	790D225X(*)050B2(#)	1.1	6	4.0
3.3	B	790D335X(*)050B2(#)	1.6	6	2.8
4.7	B	790D475X(*)050B2(#)	2.3	6	2.0
6.8	C	790D685X(*)050C2(#)	3.4	6	1.6
10	C	790D106X(*)050C2(#)	5.0	6	1.3
15	C	790D156X(*)050C2(#)	7.5	6	1.0

Note

- Extended Ratings in bold print
- (*) Insert 0 for ± 20 % tolerance or 9 for ± 10 %
- (#) See order information, packaging code

MAXIMUM PERMISSIBLE RIPPLE VOLTAGE AT + 25 °C

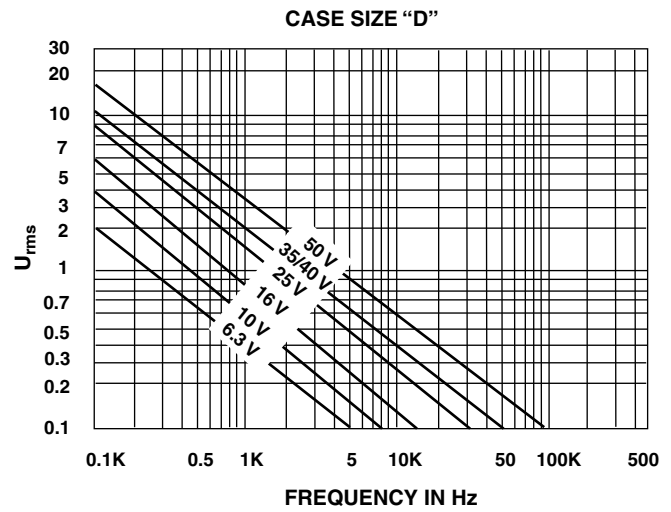
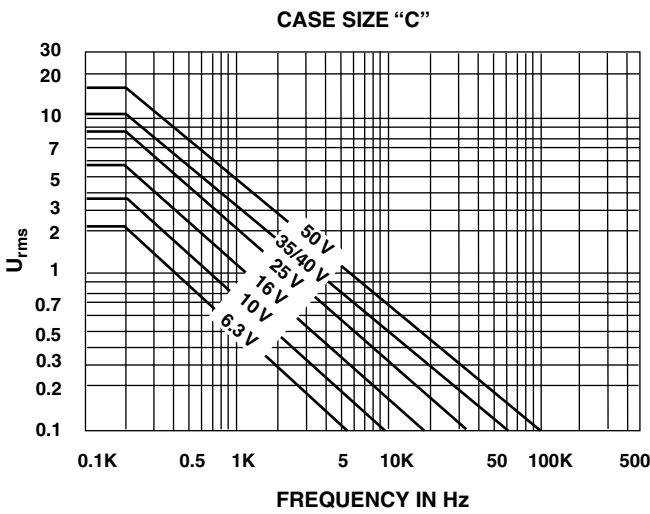
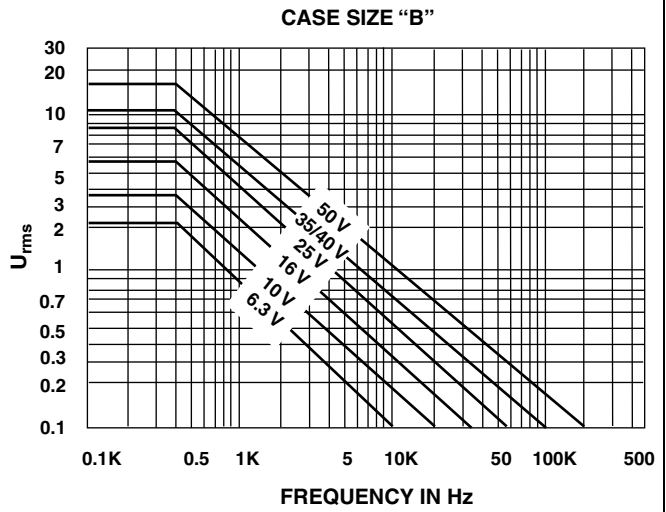
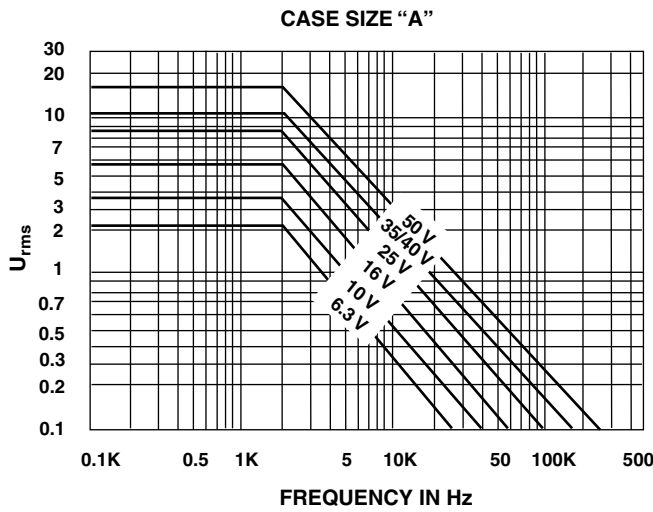

TYPICAL CURVES OF IMPEDANCE VS FREQUENCY

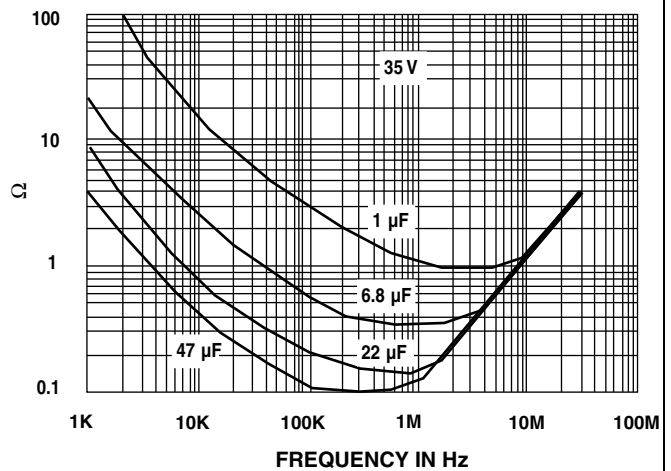
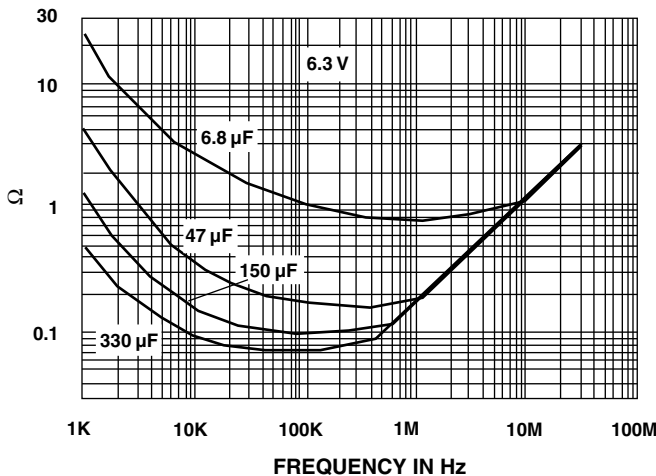



PERFORMANCE CHARACTERISTICS

1. **Operating Temperature:** - 55 °C to + 85 °C with rated voltage U_R applied. + 85 °C to 125 °C with linear voltage derating to category voltage U_C (see general information) applied.
2. **Capacitance and Tolerance:**
Capacitance measured at 100 Hz and + 25 °C shall be within the specified tolerance limits of the nominal rating
3. **Reverse Voltage:** 15 % of rated voltage at + 25 °C
5 % of rated voltage at + 85 °C
4. **Surge Voltage:** 130 % of U_R at + 85 °C
130 % of U_C at + 125 °C
5. **Impedance at 100 kHz:** Measured at + 20 °C ± 5 °C, impedance shall not exceed the values listed in data sheet.
6. **Stability at low and high temperatures**
Capacitance change with temperature, dissipation factor and DC leakage current shall not exceed the limits of the following table.
7. **Life Test:** 2000 h at + 85 °C with rated voltage applied
2000 h at + 125 °C. with category voltage applied
 $\Delta C/C \leq 10\%$ of initial value
 $IL \leq 1.25$ initial limit
 $DF \leq$ initial limit
8. **Humidity Test:** 56 days at + 40 °C, 90 % relative humidity
 $\Delta C/C \leq 8\%$ of initial value
 $IL \leq$ initial limit
 $DF \leq$ initial limit
- **Charge and Discharge Test:**
1 million cycles at + 85 °C,
0.5 s charge at U_R
0.5 s discharge
Series resistance < 0.5 Ω
 $\Delta C/C \leq 5\%$ of initial value
 $IL \leq$ initial limit
 $DF \leq$ initial limit

10. **Marking:**
Top: Rating and polarity
Front: Type, date code, Sprague trademark

TEMP.	CAPACITANCE CHANGE $C_R U_R \leq 1900$ $C_R U_R > 1900$	DISSIPATION FACTOR I_L	LEAKAGE CURRENT
- 55 °C	- 10 %	9 %	-
		11 %	
+ 25 °C	-	6 %	0.01 $C_R \times U_R$ or 1 μA whichever is greater
		8 %	
+ 85 °C	+ 12 %	9 %	0.1 $C_R \times U_R$ or 10 μA whichever is greater
		11 %	
+ 125 °C	+ 15 %	12 %	0.125 $C_R \times U_R$ or 12.5 μA whichever is greater
		14 %	

TAPE AND REEL PACKING

"A" AND "B" CASES ONLY (MEETS IEC 286-2)

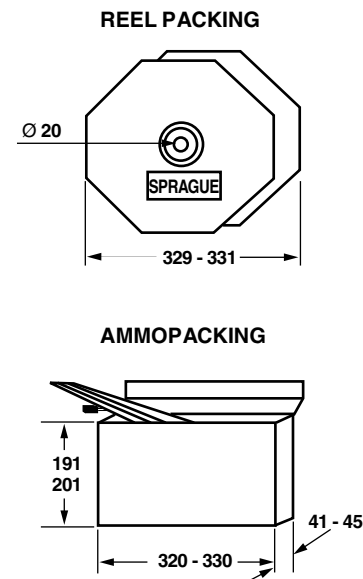
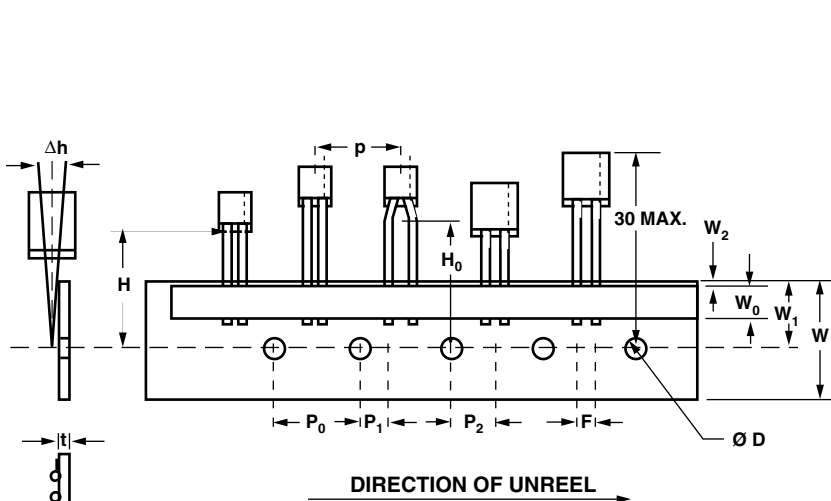

CASE CODE	TAPE WIDTH [mm]	DIMENSIONS (mm)/UNITS PER REEL		
Pitch of component	P	12.7 ± 1.0		
Feed hole pitch	P ₀	12.7 ± 0.3		
Tape width	W	18 (+ 1/- 0.5)		
Hold down tape width	W ₀	5.0		
Hole position	W ₁	9 (+ 0.75/-0.5)		
Hold down tape position	W ₂	0 (+ 3/-0)		
Feed hole diameter	D ₀	4.0 ± 0.3		
Tape thickness	T	0.5 ± 0.2		
Component alignment	Δh	0 ± 2		
Lead clinch height	H ₀	16.0 ± 0.5		
Hole center to component center	P ₂	6.35 ± 1.3		
Lead wire spacing Feed hole center to wire center	F P ₁	CASE A 2.5 + 0.6, - 0.1 5.1 ± 0.7	CASE B 5 + 0.6, - 0.1 3.85 ± 0.7	CASE B 5 + 0.6, - 0.1 3.85 ± 0.7
Reel pack options	H = 16.5 H = 18.5	X Y	Z	X Y
Ammopack options	H = 16.5 H = 18.5	G H	I	G H
Quantity per reel/box		1000	1000	1000



Disclaimer

ALL PRODUCT, PRODUCT SPECIFICATIONS AND DATA ARE SUBJECT TO CHANGE WITHOUT NOTICE TO IMPROVE RELIABILITY, FUNCTION OR DESIGN OR OTHERWISE.

Vishay Intertechnology, Inc., its affiliates, agents, and employees, and all persons acting on its or their behalf (collectively, "Vishay"), disclaim any and all liability for any errors, inaccuracies or incompleteness contained in any datasheet or in any other disclosure relating to any product.

Vishay makes no warranty, representation or guarantee regarding the suitability of the products for any particular purpose or the continuing production of any product. To the maximum extent permitted by applicable law, Vishay disclaims (i) any and all liability arising out of the application or use of any product, (ii) any and all liability, including without limitation special, consequential or incidental damages, and (iii) any and all implied warranties, including warranties of fitness for particular purpose, non-infringement and merchantability.

Statements regarding the suitability of products for certain types of applications are based on Vishay's knowledge of typical requirements that are often placed on Vishay products in generic applications. Such statements are not binding statements about the suitability of products for a particular application. It is the customer's responsibility to validate that a particular product with the properties described in the product specification is suitable for use in a particular application. Parameters provided in datasheets and/or specifications may vary in different applications and performance may vary over time. All operating parameters, including typical parameters, must be validated for each customer application by the customer's technical experts. Product specifications do not expand or otherwise modify Vishay's terms and conditions of purchase, including but not limited to the warranty expressed therein.

Except as expressly indicated in writing, Vishay products are not designed for use in medical, life-saving, or life-sustaining applications or for any other application in which the failure of the Vishay product could result in personal injury or death. Customers using or selling Vishay products not expressly indicated for use in such applications do so at their own risk and agree to fully indemnify and hold Vishay and its distributors harmless from and against any and all claims, liabilities, expenses and damages arising or resulting in connection with such use or sale, including attorneys fees, even if such claim alleges that Vishay or its distributor was negligent regarding the design or manufacture of the part. Please contact authorized Vishay personnel to obtain written terms and conditions regarding products designed for such applications.

No license, express or implied, by estoppel or otherwise, to any intellectual property rights is granted by this document or by any conduct of Vishay. Product names and markings noted herein may be trademarks of their respective owners.

Material Category Policy

Vishay Intertechnology, Inc. hereby certifies that all its products that are identified as RoHS-Compliant fulfill the definitions and restrictions defined under Directive 2011/65/EU of The European Parliament and of the Council of June 8, 2011 on the restriction of the use of certain hazardous substances in electrical and electronic equipment (EEE) - recast, unless otherwise specified as non-compliant.

Please note that some Vishay documentation may still make reference to RoHS Directive 2002/95/EC. We confirm that all the products identified as being compliant to Directive 2002/95/EC conform to Directive 2011/65/EU.