

# LM8364

*LM8364 Micropower Undervoltage Sensing Circuits*



Literature Number: SNVS232A

# LM8364

## Micropower Undervoltage Sensing Circuits

### General Description

The LM8364 series are micropower undervoltage sensing circuits that are ideal for use in battery powered microprocessor based systems, where extended battery life is a key requirement.

A range of threshold voltages from 2.0V to 4.5V are available with an active low open drain output. These devices feature a very low quiescent current of 0.65µA typical. The LM8364 series features a highly accurate voltage reference, a comparator with precise thresholds and built-in hysteresis to prevent erratic reset operation, and guaranteed Reset operation down to 1.0V with extremely low standby current.

These devices are available in the space saving SOT23 5-pin surface mount package. For other undervoltage thresholds and output options, please contact National Semiconductor.

### Features

- Extremely Low Quiescent Current: 0.65µA, at  $V_{IN} = 2.87V$
- High Accuracy Threshold Voltage ( $\pm 2.5\%$ )
- Open Drain Output
- Input Voltage Range: 1V to 6V
- Surface Mount Package (5-Pin SOT23)
- Pin for pin compatible with MC33464

### Applications

- Low Battery Detection
- Microprocessor reset Controller
- Power Fail Indicator
- Battery Backup Detection

### Functional Block Diagram

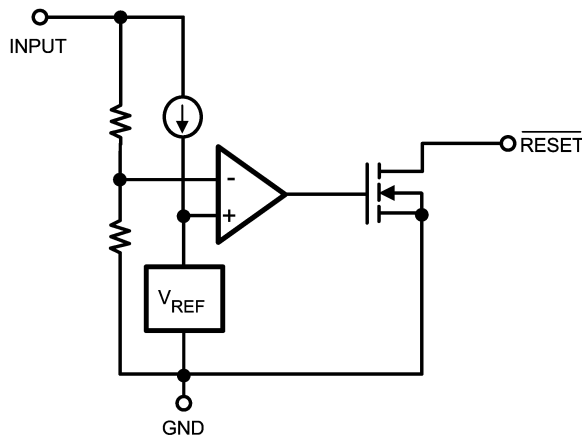

20065907

### Connection Diagram

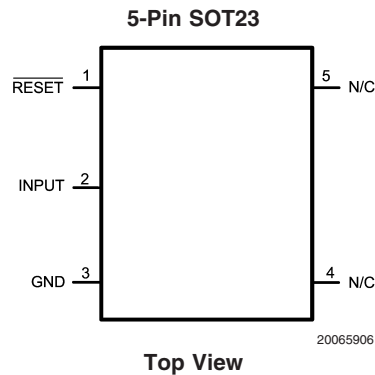

## Pin Description

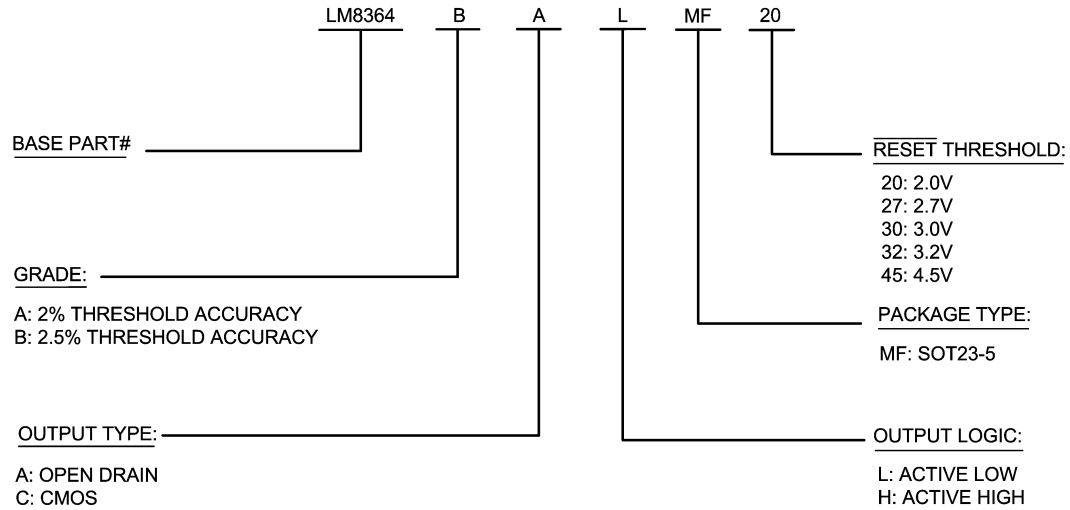

20065908

## Ordering Information

Package	Part Number	Package Marking	Threshold	Output Type	Transport Media	NSC Drawing
5-Pin SOT23	LM8364BALMF20	F01A	2.0V	Open Drain, Active Low	1k Units Tape and Reel	MF05A
	LM8364BALMFX20				3k Units Tape and Reel	
	LM8364BALMF27	F15A	2.7V	Open Drain, Active Low	1k Units Tape and Reel	
	LM8364BALMFX27				3k Units Tape and Reel	
	LM8364BALMF30	F05A	3.0V	Open Drain, Active Low	1k Units Tape and Reel	
	LM8364BALMFX30				3k Units Tape and Reel	
	LM8364BALMF32	F16A	3.2V	Open Drain, Active Low	1k Units Tape and Reel	
	LM8364BALMFX32				3k Units Tape and Reel	
	LM8364BALMF45	F04A	4.5V	Open Drain, Active Low	1k Units Tape and Reel	
LM8364BALMFX45	3k Units Tape and Reel					

**Absolute Maximum Ratings** (Note 1)

If Military/Aerospace specified devices are required, please contact the National Semiconductor Sales Office/Distributors for availability and specifications.

Supply Voltage	-0.3V to 6.5V
$\overline{\text{RESET}}$ Output Voltage	-0.3V to 6.5V
$\overline{\text{RESET}}$ Output Current	70mA
Storage Temperature Range	-65°C to 150°C
Mounting Temp.	
Lead temp (Soldering, 10 sec)	260°C

Junction Temperature

125°

**Operating Ratings** (Note 1)

Temperature Range	-40°C to 85°C
Thermal Resistance to ambient ( $\theta_{JA}$ )	265°C/W
ESD Tolerance	
Human Body Model	2000V
Machine Model	200V

**Electrical Characteristics**

Unless otherwise specified, all limits guaranteed for  $T_A = 25^\circ\text{C}$ .

Symbol	Parameter	Conditions	Min (Note 3)	Typ (Note 2)	Max (Note 3)	Units
$V_{\text{DET-}}$	Detector Threshold Voltage	High to Low State Output ( $V_{\text{IN}}$ Decreasing) 20 Suffix 27 Suffix 30 Suffix 32 Suffix 45 Suffix	1.950 2.633 2.925 3.120 4.388	2.0 2.7 3.0 3.2 4.5	2.050 2.767 3.075 3.280 4.613	V
$V_{\text{HYS}}$	Detector Threshold Hysteresis	$V_{\text{IN}}$ Increasing 20 Suffix 27 Suffix 30 Suffix 32 Suffix 45 Suffix	0.060 0.081 0.090 0.096 0.135	0.100 0.135 0.150 0.160 0.225	0.140 0.189 0.210 0.224 0.315	V
$\Delta V_{\text{det}}/\Delta T$	Detector Threshold Voltage Temperature Coefficient			±100		PPM/°C
$V_{\text{OL}}$	$\overline{\text{RESET}}$ Output Voltage Low State	(Open Drain Output: $I_{\text{SINK}} = 1\text{mA}$ )		0.25	0.5	V
$I_{\text{OL}}$	$\overline{\text{RESET}}$ Output Sink Current	$V_{\text{IN}} = 1.5\text{V}$ , $V_{\text{OL}} = 0.5\text{V}$	1.0	2.5		mA
$V_{\text{IN}}$	Operating Input Voltage Range		1.0		6.0	V
$I_{\text{IN}}$	Quiescent Input Current	20 Suffix $V_{\text{IN}} = 1.9\text{V}$ $V_{\text{IN}} = 4.0\text{V}$ 27 Suffix $V_{\text{IN}} = 2.6\text{V}$ $V_{\text{IN}} = 4.7\text{V}$ 30 Suffix $V_{\text{IN}} = 2.87\text{V}$ $V_{\text{IN}} = 5.0\text{V}$ 32 Suffix $V_{\text{IN}} = 3.08\text{V}$ $V_{\text{IN}} = 5.20\text{V}$ 45 Suffix $V_{\text{IN}} = 4.34\text{V}$ $V_{\text{IN}} = 6.0$		0.55 0.70 0.62 0.75 0.65 0.77 0.66 0.79 0.70 0.85	0.8 1.3 0.9 1.3 0.9 1.3 0.9 1.3 1.0 1.4	µA
$t_p$	Propagation Delay Time <i>Figure 1</i>			60	300	µs

## Electrical Characteristics (Continued)

**Note 1:** Absolute Maximum Ratings indicate limits beyond which damage to the device may occur. Operating Ratings indicate conditions for which the device is intended to be functional, but specific performance is not guaranteed. For guaranteed specifications and the test conditions, see the Electrical Characteristics.

**Note 2:** Typical values represent the most likely parametric norm

**Note 3:** All limits are guaranteed by testing or statistical analysis.

# Typical Performance Characteristics

**Input Current vs. Input Voltage**  
LM8364BALMF45

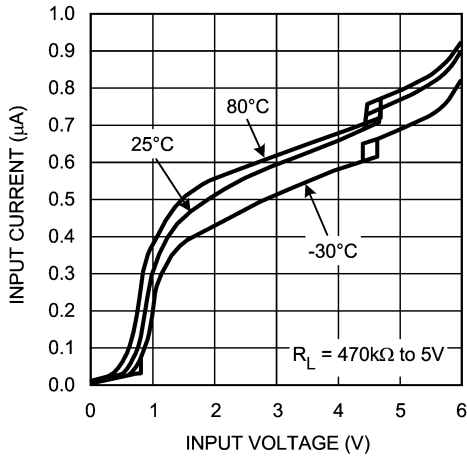

20065901

**Reset Output Voltage vs. Input Voltage**  
LM8364BALMF45

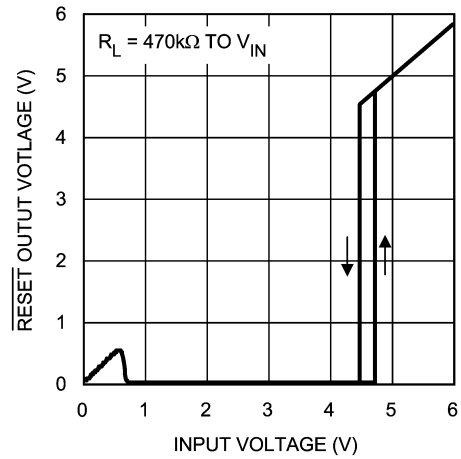

20065902

**Reset Output Sink Current vs. Input Voltage**  
LM8364BALMF45

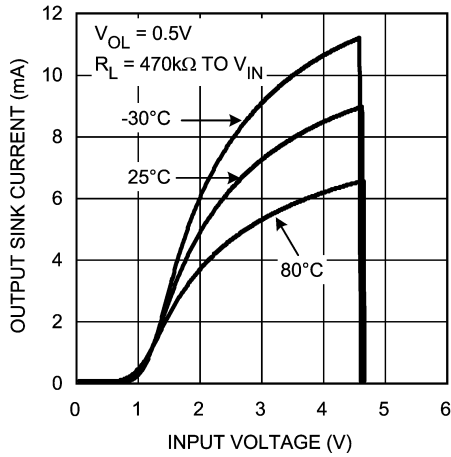

20065903

**Reset Output Sink Current vs. Output Voltage**  
LM8364BALMF45

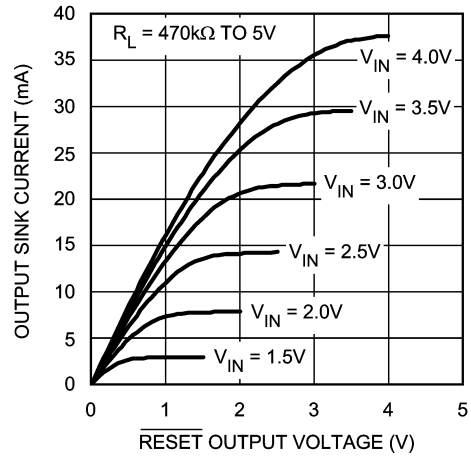

20065904

**Detector Threshold Voltage vs. Temperature**  
LM8364BALMF45

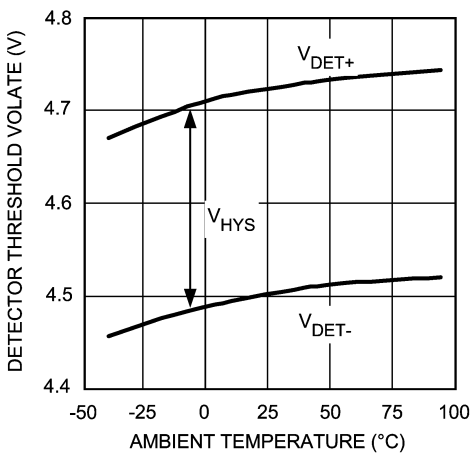

20065905

## Application Notes

The propagation delay time for the LM8364 is measured using a 470kΩ pull-up resistor connected to from the RESET output pin to 5V in addition to a 10pF capacitive load con-

nected from the same pin to GND. *Figure 1* shows the timing diagram for the measurement for the propagation delay.  $V_{DET+}$  is equal to the sum of the detector threshold,  $V_{DET-}$ , and the built in hysteresis,  $V_{HYS}$ .

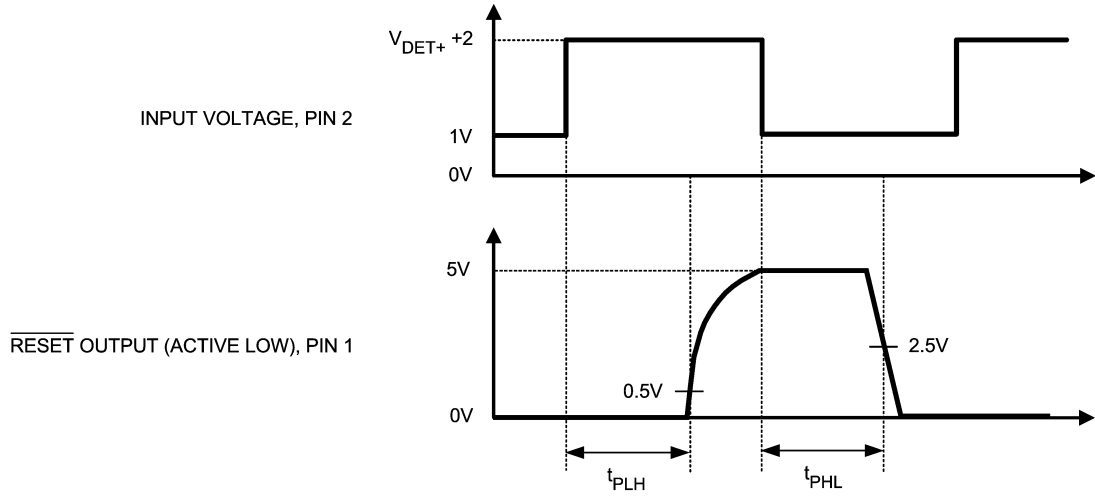

20065909

FIGURE 1. Propagation Delay Timing Diagrams

The LM8364 ultra-low current voltage detector was designed to monitor voltages and to provide an indication when the monitored voltage,  $V_{IN}$ , dropped below a precisely trimmed threshold voltage. This characteristic is displayed in the typical operating timing diagram below.  $V_{IN}$  is the voltage that is being monitored and a pull up resistor is connected from the RESET output pin to  $V_{IN}$ .  $V_{IN}$  is at some value above  $V_{DET+}$  and then begins to decrease. Since this is an Active Low device the RESET output is pulled High through the pull-up resistor and tracks  $V_{IN}$  until  $V_{IN}$  crosses the trimmed threshold  $V_{DET-}$ . At this point the LM8364 recognizes that  $V_{IN}$  is now in a fault condition and the output immediately changes to the Logic Low State. The RESET output will remain in this low state until  $V_{IN}$  increases above the threshold  $V_{DET-} +$

$V_{HYS}$ . This point is also known as  $V_{DET+}$  as indicated earlier. This built-in hysteresis has been added to the design to help prevent erratic reset operation when the input voltage crosses the threshold.

The LM8364 has a wide variety of applications that can take advantage of its precision and low current consumption to monitor Input voltages even though it was designed as a reset controller in portable microprocessor based systems. It is a very cost effective and space saving device that will protect your more expensive investments of microprocessors and other devices that need a guaranteed supply voltage for proper operation.

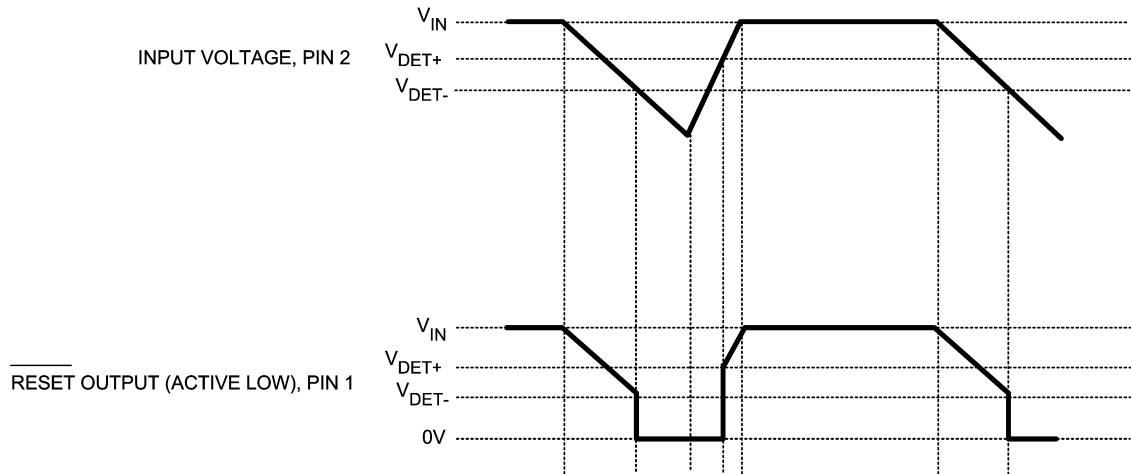

20065910

FIGURE 2. Timing Waveforms

### Typical Applications

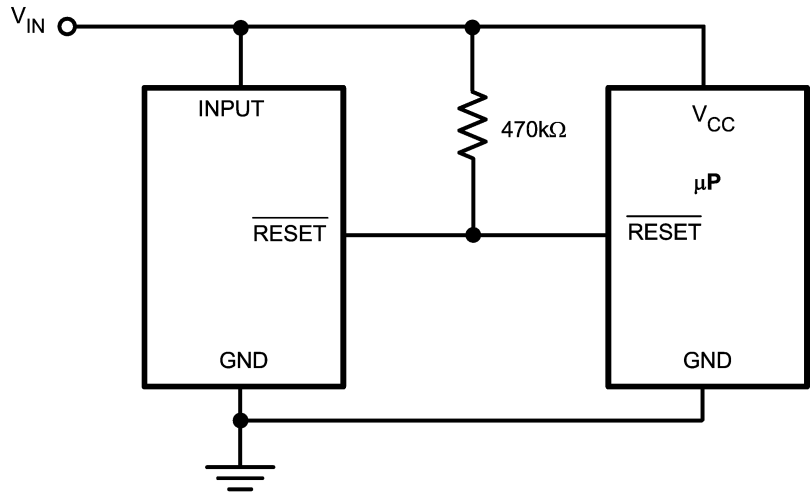

Microprocessor Reset Circuit

20065911

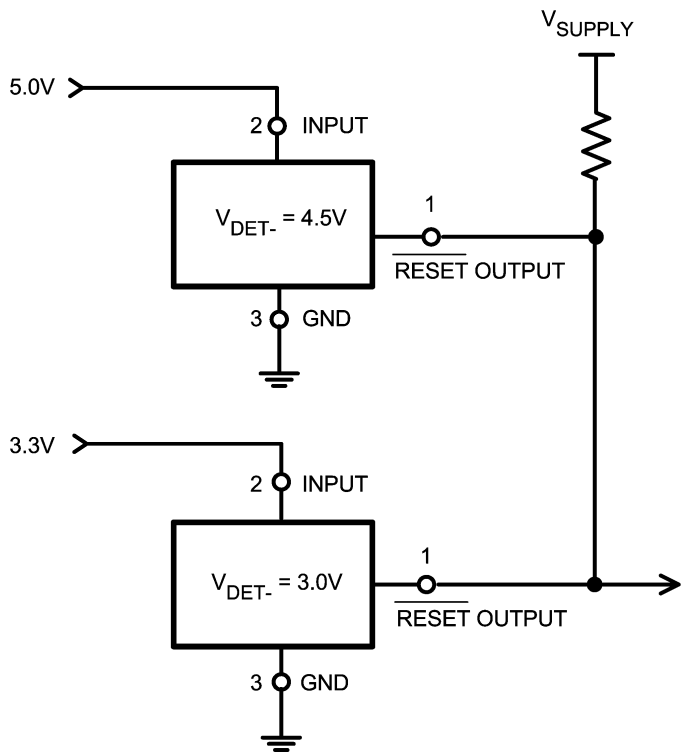

Dual Power Supply Undervoltage Supervision

20065912

Typical Applications (Continued)

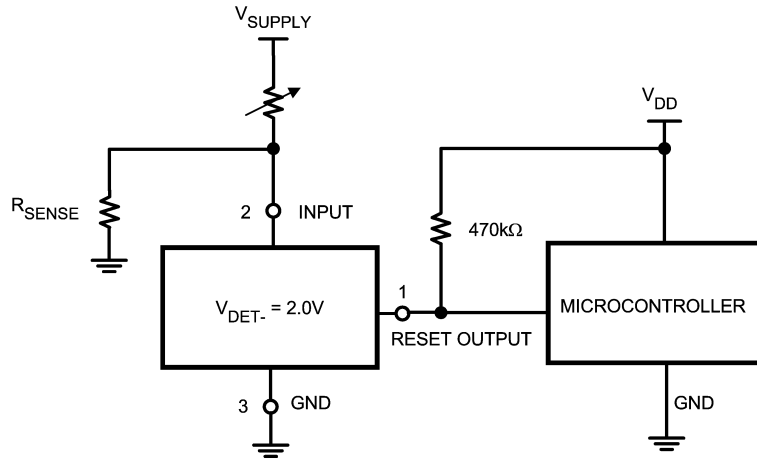

THIS CIRCUIT MONITORS THE CURRENT AT THE LOAD. AS CURRENT FLOW THROUGH THE LOAD, A VOLTAGE DROP WITH RESPECT TO GROUND APPEARS ACROSS  $R_{SENSE}$  WHERE  $V_{SENSE} = I_{LOAD} * R_{SENSE}$ . THE FOLLOWING CONDITIONS APPLY:

IF:	THEN:
$I_{LOAD} < V_{DET.} / R_{SENSE}$	RESET OUTPUT = 0V
$I_{LOAD} \geq (V_{DET.} + V_{HYS}) / R_{SENSE}$	RESET OUTPUT = $V_{DD}$

20065913

Microcontroller System Load Sensing

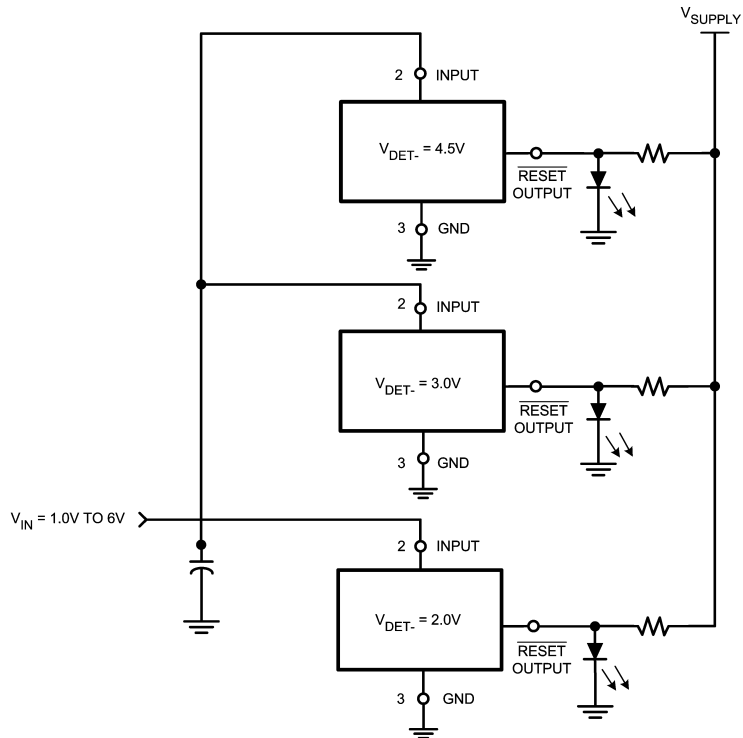

EACH LED WILL SEQUENTIALLY TURN ON WHEN THE RESPECTIVE VOLTAGE DETECTOR THRESHOLD ( $V_{DET.} + V_{HYS}$ ) IS EXCEEDED.

20065914

LED Bar Graph Voltage Monitor

## Physical Dimensions inches (millimeters)

unless otherwise noted

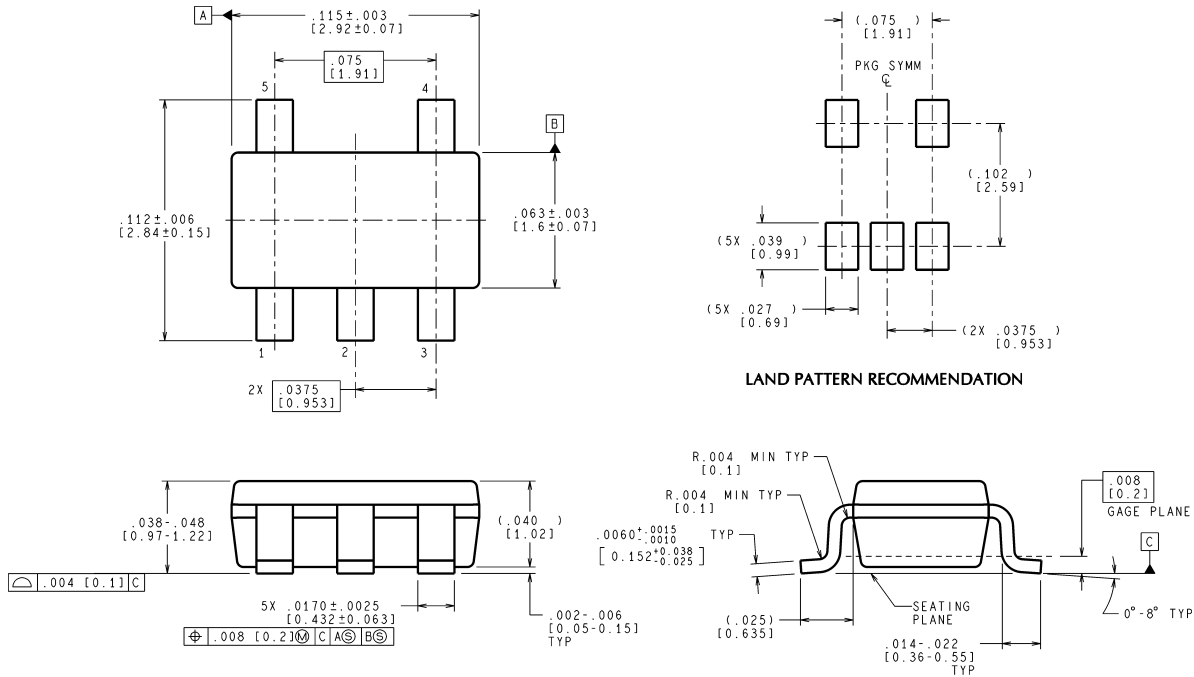

CONTROLLING DIMENSION IS INCH  
VALUES IN [ ] ARE MILLIMETERS

**5-Pin SOT23**  
**NSC Package Number MF05A**

MF05A (Rev B)

National does not assume any responsibility for use of any circuitry described, no circuit patent licenses are implied and National reserves the right at any time without notice to change said circuitry and specifications.

For the most current product information visit us at [www.national.com](http://www.national.com).

### LIFE SUPPORT POLICY

NATIONAL'S PRODUCTS ARE NOT AUTHORIZED FOR USE AS CRITICAL COMPONENTS IN LIFE SUPPORT DEVICES OR SYSTEMS WITHOUT THE EXPRESS WRITTEN APPROVAL OF THE PRESIDENT AND GENERAL COUNSEL OF NATIONAL SEMICONDUCTOR CORPORATION. As used herein:

1. Life support devices or systems are devices or systems which, (a) are intended for surgical implant into the body, or (b) support or sustain life, and whose failure to perform when properly used in accordance with instructions for use provided in the labeling, can be reasonably expected to result in a significant injury to the user.
2. A critical component is any component of a life support device or system whose failure to perform can be reasonably expected to cause the failure of the life support device or system, or to affect its safety or effectiveness.

### BANNED SUBSTANCE COMPLIANCE

National Semiconductor manufactures products and uses packing materials that meet the provisions of the Customer Products Stewardship Specification (CSP-9-111C2) and the Banned Substances and Materials of Interest Specification (CSP-9-111S2) and contain no "Banned Substances" as defined in CSP-9-111S2.



**National Semiconductor**  
**Americas Customer Support Center**  
Email: [new.feedback@nsc.com](mailto:new.feedback@nsc.com)  
Tel: 1-800-272-9959

**National Semiconductor**  
**Europe Customer Support Center**  
Fax: +49 (0) 180-530 85 86  
Email: [europe.support@nsc.com](mailto:europe.support@nsc.com)  
Deutsch Tel: +49 (0) 69 9508 6208  
English Tel: +44 (0) 870 24 0 2171  
Français Tel: +33 (0) 1 41 91 8790

**National Semiconductor**  
**Asia Pacific Customer Support Center**  
Email: [ap.support@nsc.com](mailto:ap.support@nsc.com)

**National Semiconductor**  
**Japan Customer Support Center**  
Fax: 81-3-5639-7507  
Email: [jpn.feedback@nsc.com](mailto:jpn.feedback@nsc.com)  
Tel: 81-3-5639-7560

[www.national.com](http://www.national.com)

## IMPORTANT NOTICE

Texas Instruments Incorporated and its subsidiaries (TI) reserve the right to make corrections, modifications, enhancements, improvements, and other changes to its products and services at any time and to discontinue any product or service without notice. Customers should obtain the latest relevant information before placing orders and should verify that such information is current and complete. All products are sold subject to TI's terms and conditions of sale supplied at the time of order acknowledgment.

TI warrants performance of its hardware products to the specifications applicable at the time of sale in accordance with TI's standard warranty. Testing and other quality control techniques are used to the extent TI deems necessary to support this warranty. Except where mandated by government requirements, testing of all parameters of each product is not necessarily performed.

TI assumes no liability for applications assistance or customer product design. Customers are responsible for their products and applications using TI components. To minimize the risks associated with customer products and applications, customers should provide adequate design and operating safeguards.

TI does not warrant or represent that any license, either express or implied, is granted under any TI patent right, copyright, mask work right, or other TI intellectual property right relating to any combination, machine, or process in which TI products or services are used. Information published by TI regarding third-party products or services does not constitute a license from TI to use such products or services or a warranty or endorsement thereof. Use of such information may require a license from a third party under the patents or other intellectual property of the third party, or a license from TI under the patents or other intellectual property of TI.

Reproduction of TI information in TI data books or data sheets is permissible only if reproduction is without alteration and is accompanied by all associated warranties, conditions, limitations, and notices. Reproduction of this information with alteration is an unfair and deceptive business practice. TI is not responsible or liable for such altered documentation. Information of third parties may be subject to additional restrictions.

Resale of TI products or services with statements different from or beyond the parameters stated by TI for that product or service voids all express and any implied warranties for the associated TI product or service and is an unfair and deceptive business practice. TI is not responsible or liable for any such statements.

TI products are not authorized for use in safety-critical applications (such as life support) where a failure of the TI product would reasonably be expected to cause severe personal injury or death, unless officers of the parties have executed an agreement specifically governing such use. Buyers represent that they have all necessary expertise in the safety and regulatory ramifications of their applications, and acknowledge and agree that they are solely responsible for all legal, regulatory and safety-related requirements concerning their products and any use of TI products in such safety-critical applications, notwithstanding any applications-related information or support that may be provided by TI. Further, Buyers must fully indemnify TI and its representatives against any damages arising out of the use of TI products in such safety-critical applications.

TI products are neither designed nor intended for use in military/aerospace applications or environments unless the TI products are specifically designated by TI as military-grade or "enhanced plastic." Only products designated by TI as military-grade meet military specifications. Buyers acknowledge and agree that any such use of TI products which TI has not designated as military-grade is solely at the Buyer's risk, and that they are solely responsible for compliance with all legal and regulatory requirements in connection with such use.

TI products are neither designed nor intended for use in automotive applications or environments unless the specific TI products are designated by TI as compliant with ISO/TS 16949 requirements. Buyers acknowledge and agree that, if they use any non-designated products in automotive applications, TI will not be responsible for any failure to meet such requirements.

Following are URLs where you can obtain information on other Texas Instruments products and application solutions:

### Products

Audio	<a href="http://www.ti.com/audio">www.ti.com/audio</a>
Amplifiers	<a href="http://amplifier.ti.com">amplifier.ti.com</a>
Data Converters	<a href="http://dataconverter.ti.com">dataconverter.ti.com</a>
DLP® Products	<a href="http://www.dlp.com">www.dlp.com</a>
DSP	<a href="http://dsp.ti.com">dsp.ti.com</a>
Clocks and Timers	<a href="http://www.ti.com/clocks">www.ti.com/clocks</a>
Interface	<a href="http://interface.ti.com">interface.ti.com</a>
Logic	<a href="http://logic.ti.com">logic.ti.com</a>
Power Mgmt	<a href="http://power.ti.com">power.ti.com</a>
Microcontrollers	<a href="http://microcontroller.ti.com">microcontroller.ti.com</a>
RFID	<a href="http://www.ti-rfid.com">www.ti-rfid.com</a>
OMAP Mobile Processors	<a href="http://www.ti.com/omap">www.ti.com/omap</a>
Wireless Connectivity	<a href="http://www.ti.com/wirelessconnectivity">www.ti.com/wirelessconnectivity</a>

### Applications

Communications and Telecom	<a href="http://www.ti.com/communications">www.ti.com/communications</a>
Computers and Peripherals	<a href="http://www.ti.com/computers">www.ti.com/computers</a>
Consumer Electronics	<a href="http://www.ti.com/consumer-apps">www.ti.com/consumer-apps</a>
Energy and Lighting	<a href="http://www.ti.com/energy">www.ti.com/energy</a>
Industrial	<a href="http://www.ti.com/industrial">www.ti.com/industrial</a>
Medical	<a href="http://www.ti.com/medical">www.ti.com/medical</a>
Security	<a href="http://www.ti.com/security">www.ti.com/security</a>
Space, Avionics and Defense	<a href="http://www.ti.com/space-avionics-defense">www.ti.com/space-avionics-defense</a>
Transportation and Automotive	<a href="http://www.ti.com/automotive">www.ti.com/automotive</a>
Video and Imaging	<a href="http://www.ti.com/video">www.ti.com/video</a>

TI E2E Community Home Page

[e2e.ti.com](http://e2e.ti.com)

Mailing Address: Texas Instruments, Post Office Box 655303, Dallas, Texas 75265  
Copyright © 2011, Texas Instruments Incorporated