

LM138/LM338 5-Amp Adjustable Regulators

 Check for Samples: [LM138](#), [LM338](#)

FEATURES

- Specified 7A Peak Output Current
- Specified 5A Output Current
- Adjustable Output Down to 1.2V
- Specified Thermal Regulation
- Current Limit Constant with Temperature
- P⁺ Product Enhancement Tested
- Output is Short-Circuit Protected

APPLICATIONS

- Adjustable Power Supplies
- Constant Current Regulators
- Battery Chargers

DESCRIPTION

The LM138 series of adjustable 3-terminal positive voltage regulators is capable of supplying in excess of 5A over a 1.2V to 32V output range. They are exceptionally easy to use and require only 2 resistors to set the output voltage. Careful circuit design has resulted in outstanding load and line regulation—comparable to many commercial power supplies. The LM138 family is supplied in a standard 3-lead transistor package.

A unique feature of the LM138 family is time-dependent current limiting. The current limit circuitry allows peak currents of up to 12A to be drawn from the regulator for short periods of time. This allows the LM138 to be used with heavy transient loads and speeds start-up under full-load conditions. Under sustained loading conditions, the current limit decreases to a safe value protecting the regulator. Also included on the chip are thermal overload protection and safe area protection for the power transistor. Overload protection remains functional even if the adjustment pin is accidentally disconnected.

Normally, no capacitors are needed unless the device is situated more than 6 inches from the input filter capacitors in which case an input bypass is needed. An output capacitor can be added to improve transient response, while bypassing the adjustment pin will increase the regulator's ripple rejection.

Besides replacing fixed regulators or discrete designs, the LM138 is useful in a wide variety of other applications. Since the regulator is "floating" and sees only the input-to-output differential voltage, supplies of several hundred volts can be regulated as long as the maximum input to output differential is not exceeded, i.e., do not short-circuit output to ground. The part numbers in the LM138 series which have a K suffix are packaged in a standard Steel TO-3 package, while those with a T suffix are packaged in a TO-220 plastic package. The LM138 is rated for $-55^{\circ}\text{C} \leq T_J \leq +150^{\circ}\text{C}$, and the LM338 is rated for $0^{\circ}\text{C} \leq T_J \leq +125^{\circ}\text{C}$.

Connection Diagram

Connection Diagrams

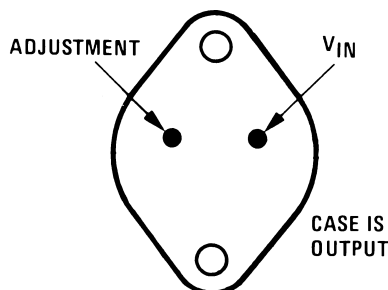

**Figure 1. (TO-3) Metal Can Package
Bottom View**
See Package Number NDS0002A

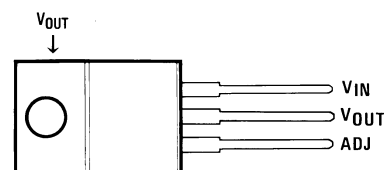

**Figure 2. (TO-220) Plastic Package
Front View**
See Package Number NDE0003B



Please be aware that an important notice concerning availability, standard warranty, and use in critical applications of Texas Instruments semiconductor products and disclaimers thereto appears at the end of this data sheet.

All trademarks are the property of their respective owners.



These devices have limited built-in ESD protection. The leads should be shorted together or the device placed in conductive foam during storage or handling to prevent electrostatic damage to the MOS gates.

Absolute Maximum Ratings⁽¹⁾⁽²⁾⁽³⁾

Power Dissipation	Internally limited
Input/Output Voltage Differential	+40V, -0.3V
Storage Temperature	-65°C to +150°C
Lead Temperature	
TO-3 Package (Soldering, 10 seconds)	300°C
TO-220 Package (Soldering, 4 seconds)	260°C
ESD Tolerance	TBD

- (1) Absolute Maximum Ratings indicate limits beyond which damage to the device may occur. Operating Ratings indicate conditions for which the device is intended to be functional, but do not ensure specific performance limits. For ensured specifications and test conditions, see the Electrical Characteristics.
- (2) Refer to RETS138K drawing for military specifications of LM138K.
- (3) If Military/Aerospace specified devices are required, please contact the TI Sales Office/ Distributors for availability and specifications.

Operating Temperature Range

LM138	-55°C ≤ T _J ≤ +150°C
LM338	0°C ≤ T _J ≤ +125°C

Electrical Characteristics

Specifications with standard type face are for T_J = 25°C, and those with **boldface type** apply over **full Operating Temperature Range**. Unless otherwise specified, V_{IN} - V_{OUT} = 5V; and I_{OUT} = 10 mA. ⁽¹⁾

Symbol	Parameter	Conditions	LM138			Units
			Min	Typ	Max	
V _{REF}	Reference Voltage	3V ≤ (V _{IN} - V _{OUT}) ≤ 35V, 10 mA ≤ I _{OUT} ≤ 5A, P ≤ 50W	1.19	1.24	1.29	V
V _{RLINE}	Line Regulation	3V ≤ (V _{IN} - V _{OUT}) ≤ 35V ⁽²⁾		0.005	0.01	%/V
V _{RLOAD}	Load Regulation	10 mA ≤ I _{OUT} ≤ 5A ⁽²⁾		0.02	0.04	%/V
				0.1	0.3	%
	Thermal Regulation	20 ms Pulse		0.3	0.6	%
I _{ADJ}	Adjustment Pin Current			0.002	0.01	%/W
ΔI _{ADJ}	Adjustment Pin Current Change			45	100	μA
ΔI _{ADJ}	Adjustment Pin Current Change	10 mA ≤ I _{OUT} ≤ 5A, 3V ≤ (V _{IN} - V _{OUT}) ≤ 35V		0.2	5	μA
ΔV _{R/T}	Temperature Stability	T _{MIN} ≤ T _J ≤ T _{MAX}		1		%
I _{LOAD(Min)}	Minimum Load Current	V _{IN} - V _{OUT} = 35V		3.5	5	mA
I _{CL}	Current Limit	V _{IN} - V _{OUT} ≤ 10V				
		DC	5	8	A	
		0.5 ms Peak	7	12	A	
		V _{IN} - V _{OUT} = 30V		1	1	A
V _N	RMS Output Noise, % of V _{OUT}	10 Hz ≤ f ≤ 10 kHz		0.003		%
ΔV _R /ΔV _{IN}	Ripple Rejection Ratio	V _{OUT} = 10V, f = 120 Hz, C _{ADJ} = 0 μF		60		dB
		V _{OUT} = 10V, f = 120 Hz, C _{ADJ} = 10 μF	60	75		dB
	Long-Term Stability	T _J = 125°C, 1000 Hrs		0.3	1	%
θ _{JC}	Thermal Resistance, Junction to Case	NDS Package			1	°C/W

- (1) These specifications are applicable for power dissipations up to 50W for the TO-3 (NDS) package and 25W for the TO-220 (NDE) package. Power dissipation is specified at these values up to 15V input-output differential. Above 15V differential, power dissipation will be limited by internal protection circuitry. All limits (i.e., the numbers in the Min. and Max. columns) are specified to TI's AOQL (Average Outgoing Quality Level).
- (2) Regulation is measured at a constant junction temperature, using pulse testing with a low duty cycle. Changes in output voltage due to heating effects are covered under the specifications for thermal regulation.

Electrical Characteristics (continued)

Specifications with standard type face are for $T_J = 25^\circ\text{C}$, and those with **boldface type** apply over **full Operating Temperature Range**. Unless otherwise specified, $V_{IN} - V_{OUT} = 5\text{V}$; and $I_{OUT} = 10\text{ mA}$. ⁽¹⁾

Symbol	Parameter	Conditions	LM138			Units
			Min	Typ	Max	
θ_{JA}	Thermal Resistance, Junction to Ambient (No Heat Sink)	NDS Package		35		$^\circ\text{C/W}$

Electrical Characteristics

Symbol	Parameter	Conditions	LM338			Units
			Min	Typ	Max	
V_{REF}	Reference Voltage	$3\text{V} \leq (V_{IN} - V_{OUT}) \leq 35\text{V}$, $10\text{ mA} \leq I_{OUT} \leq 5\text{A}$, $P \leq 50\text{W}$	1.19	1.24	1.29	V
V_{RLINE}	Line Regulation	$3\text{V} \leq (V_{IN} - V_{OUT}) \leq 35\text{V}$ ⁽¹⁾		0.005	0.03	$\%/V$
				0.02	0.06	$\%/V$
V_{RLOAD}	Load Regulation	$10\text{ mA} \leq I_{OUT} \leq 5\text{A}$ ⁽¹⁾		0.1	0.5	%
				0.3	1	%
	Thermal Regulation	20 ms Pulse		0.002	0.02	$\%/W$
I_{ADJ}	Adjustment Pin Current			45	100	μA
ΔI_{ADJ}	Adjustment Pin Current Change	$10\text{ mA} \leq I_{OUT} \leq 5\text{A}$, $3\text{V} \leq (V_{IN} - V_{OUT}) \leq 35\text{V}$		0.2	5	μA
ΔV_{RT}	Temperature Stability	$T_{MIN} \leq T_J \leq T_{MAX}$		1		%
$I_{LOAD(\text{Min})}$	Minimum Load Current	$V_{IN} - V_{OUT} = 35\text{V}$		3.5	10	mA
I_{CL}	Current Limit	$V_{IN} - V_{OUT} \leq 10\text{V}$ DC 0.5 ms Peak	5	8		A
			7	12		A
					1	A
V_N	RMS Output Noise, % of V_{OUT}	$10\text{ Hz} \leq f \leq 10\text{ kHz}$		0.003		%
$\Delta V_R/\Delta V_{IN}$	Ripple Rejection Ratio	$V_{OUT} = 10\text{V}$, $f = 120\text{ Hz}$, $C_{ADJ} = 0\text{ }\mu\text{F}$		60		dB
		$V_{OUT} = 10\text{V}$, $f = 120\text{ Hz}$, $C_{ADJ} = 10\text{ }\mu\text{F}$	60	75		dB
	Long-Term Stability	$T_J = 125^\circ\text{C}$, 1000 hrs		0.3	1	%
θ_{JC}	Thermal Resistance	NDS Package			1	$^\circ\text{C/W}$
	Junction to Case	NDE Package			4	$^\circ\text{C/W}$
θ_{JA}	Thermal Resistance, Junction to Ambient (No Heat Sink)	NDS Package		35		$^\circ\text{C/W}$
		NDE Package		50		$^\circ\text{C/W}$

(1) Regulation is measured at a constant junction temperature, using pulse testing with a low duty cycle. Changes in output voltage due to heating effects are covered under the specifications for thermal regulation.

Typical Performance Characteristics

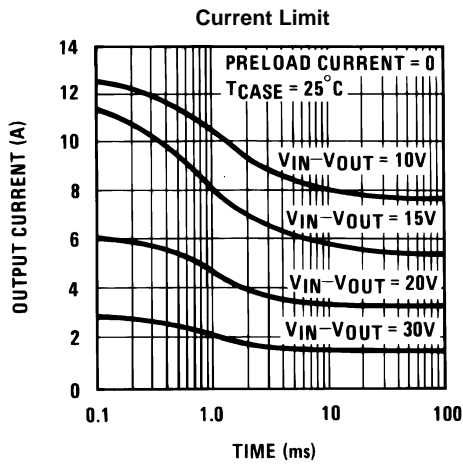

Figure 3.

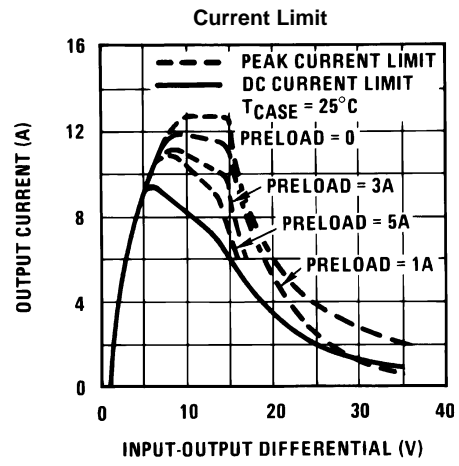

Figure 4.

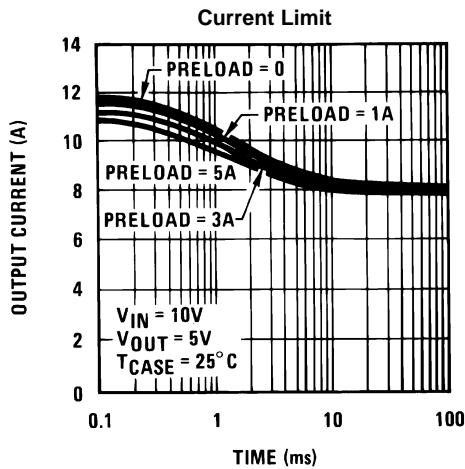

Figure 5.

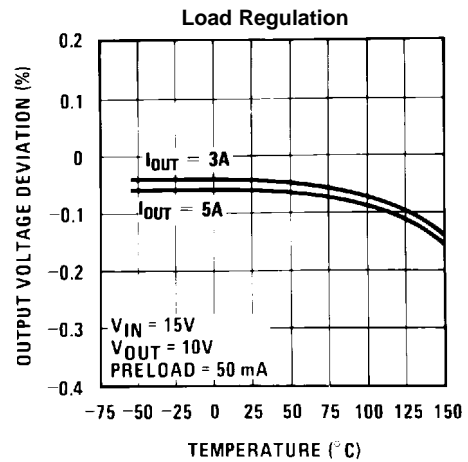

Figure 6.

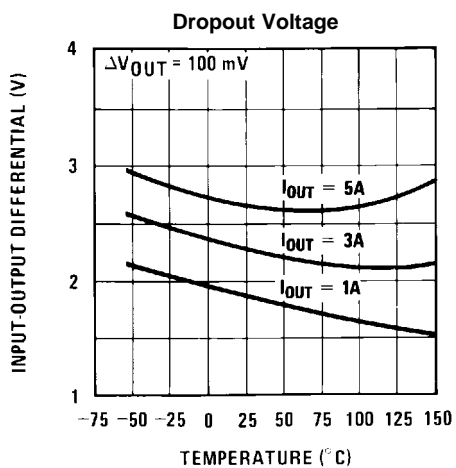

Figure .

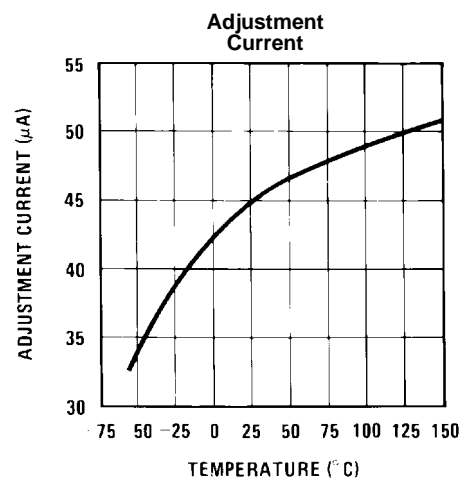

Figure 7.

Typical Performance Characteristics (continued)

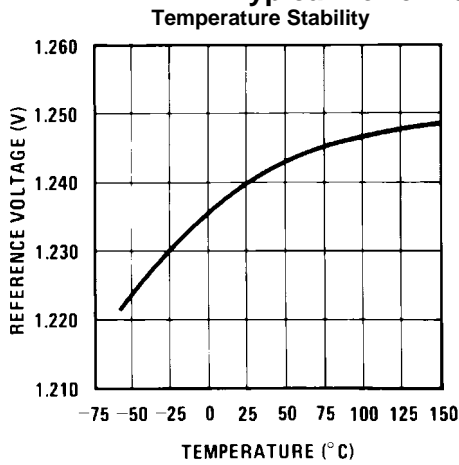

Figure 8.

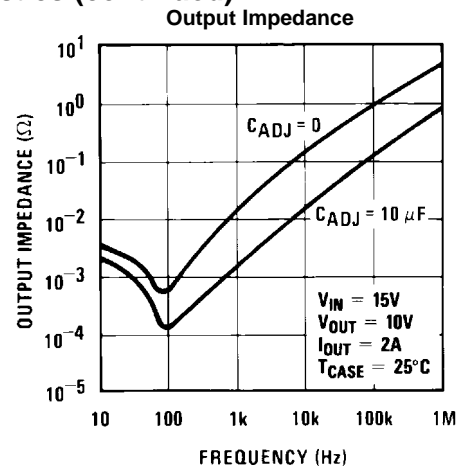

Figure 9.

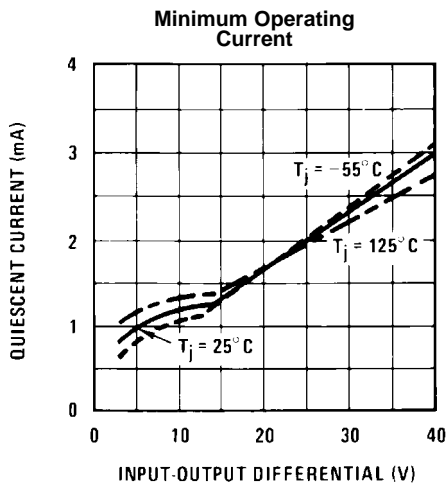

Figure 10.

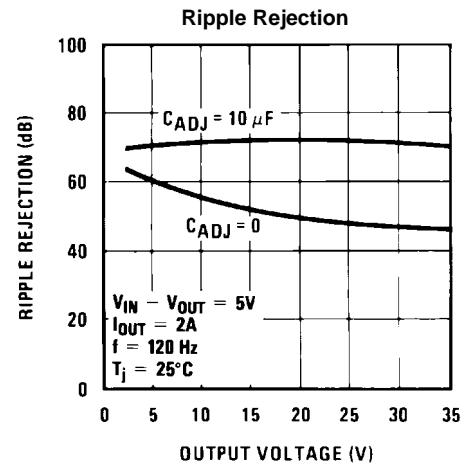

Figure 11.

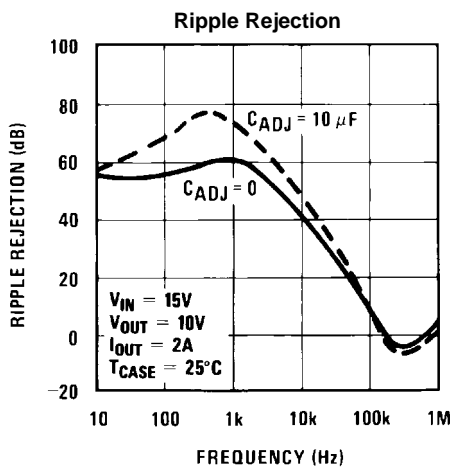

Figure 12.

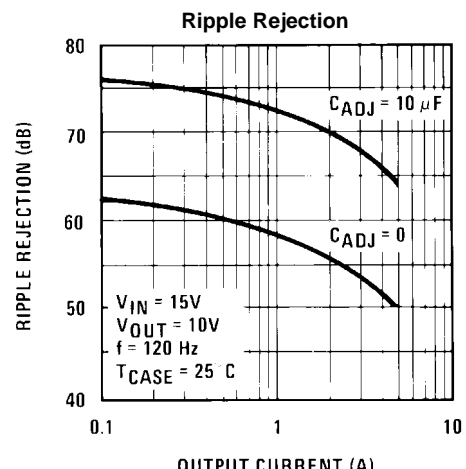

Figure 13.

Typical Performance Characteristics (continued)

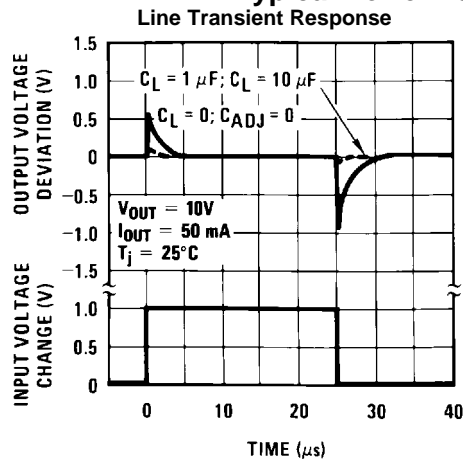

Figure 14.

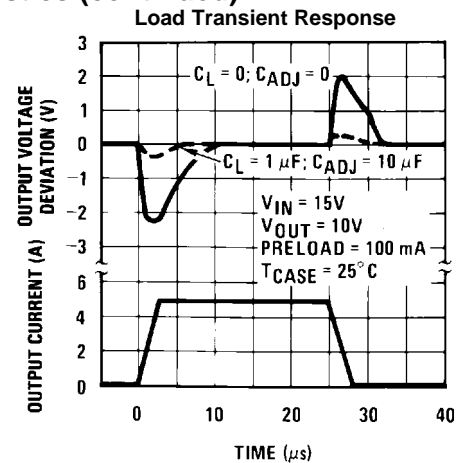
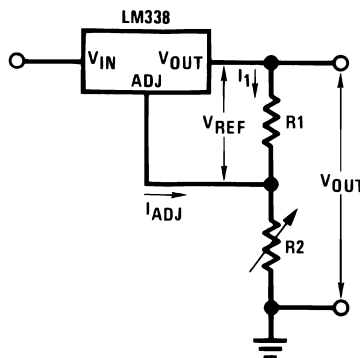

Figure 15.

APPLICATION HINTS

In operation, the LM138 develops a nominal 1.25V reference voltage, V_{REF} , between the output and adjustment terminal. The reference voltage is impressed across program resistor $R1$ and, since the voltage is constant, a constant current I_1 then flows through the output set resistor $R2$, giving an output voltage of

$$V_{OUT} = V_{REF} \left(1 + \frac{R2}{R1} \right) + I_{ADJ}R2. \quad (1)$$



Since the 50 μ A current from the adjustment terminal represents an error term, the LM138 was designed to minimize I_{ADJ} and make it very constant with line and load changes. To do this, all quiescent operating current is returned to the output establishing a minimum load current requirement. If there is insufficient load on the output, the output will rise.

EXTERNAL CAPACITORS

An input bypass capacitor is recommended. A 0.1 μ F disc or 1 μ F solid tantalum on the input is suitable input bypassing for almost all applications. The device is more sensitive to the absence of input bypassing when adjustment or output capacitors are used but the above values will eliminate the possibility of problems.

The adjustment terminal can be bypassed to ground on the LM138 to improve ripple rejection. This bypass capacitor prevents ripple from being amplified as the output voltage is increased. With a 10 μ F bypass capacitor 75 dB ripple rejection is obtainable at any output level. Increases over 20 μ F do not appreciably improve the ripple rejection at frequencies above 120 Hz. If the bypass capacitor is used, it is sometimes necessary to include protection diodes to prevent the capacitor from discharging through internal low current paths and damaging the device.

In general, the best type of capacitors to use are solid tantalum. Solid tantalum capacitors have low impedance even at high frequencies. Depending upon capacitor construction, it takes about 25 μ F in aluminum electrolytic to equal 1 μ F solid tantalum at high frequencies. Ceramic capacitors are also good at high frequencies; but some types have a large decrease in capacitance at frequencies around 0.5 MHz. For this reason, 0.01 μ F disc may seem to work better than a 0.1 μ F disc as a bypass.

Although the LM138 is stable with no output capacitors, like any feedback circuit, certain values of external capacitance can cause excessive ringing. This occurs with values between 500 pF and 5000 pF. A 1 μ F solid tantalum (or 25 μ F aluminum electrolytic) on the output swamps this effect and insures stability.

LOAD REGULATION

The LM138 is capable of providing extremely good load regulation but a few precautions are needed to obtain maximum performance. The current set resistor connected between the adjustment terminal and the output terminal (usually 240 Ω) should be tied directly to the output of the regulator (case) rather than near the load. This eliminates line drops from appearing effectively in series with the reference and degrading regulation. For example, a 15V regulator with 0.05 Ω resistance between the regulator and load will have a load regulation due to line resistance of $0.05\Omega \times I_L$. If the set resistor is connected near the load the effective line resistance will be $0.05\Omega (1 + R2/R1)$ or in this case, 11.5 times worse.

Figure 16 shows the effect of resistance between the regulator and 240 Ω set resistor.

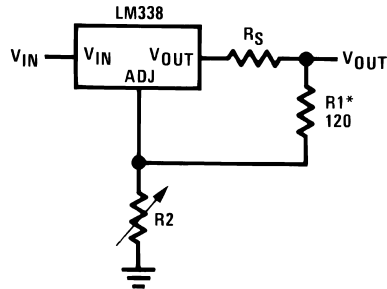

Figure 16. Regulator with Line Resistance in Output Lead

With the TO-3 package, it is easy to minimize the resistance from the case to the set resistor, by using 2 separate leads to the case. The ground of R2 can be returned near the ground of the load to provide remote ground sensing and improve load regulation.

PROTECTION DIODES

When external capacitors are used with *any* IC regulator it is sometimes necessary to add protection diodes to prevent the capacitors from discharging through low current points into the regulator. Most 20 μF capacitors have low enough internal series resistance to deliver 20A spikes when shorted. Although the surge is short, there is enough energy to damage parts of the IC.

When an output capacitor is connected to a regulator and the input is shorted, the output capacitor will discharge into the output of the regulator. The discharge current depends on the value of the capacitor, the output voltage of the regulator, and the rate of decrease of V_{IN} . In the LM138 this discharge path is through a large junction that is able to sustain 25A surge with no problem. This is not true of other types of positive regulators. For output capacitors of 100 μF or less at output of 15V or less, there is no need to use diodes.

The bypass capacitor on the adjustment terminal can discharge through a low current junction. Discharge occurs when *either* the input or output is shorted. Internal to the LM138 is a 50 Ω resistor which limits the peak discharge current. No protection is needed for output voltages of 25V or less and 10 μF capacitance. [Figure 17](#) shows an LM138 with protection diodes included for use with outputs greater than 25V and high values of output capacitance.

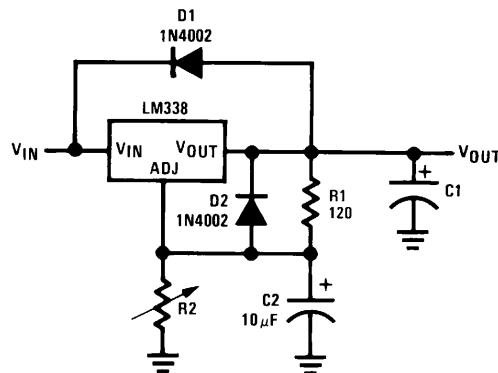

D1 protects against C1
D2 protects against C2

$$V_{\text{OUT}} = 1.25V \left(1 + \frac{R2}{R1} \right) + I_{\text{ADJ}}R2$$

Figure 17. Regulator with Protection Diodes

Typical Applications

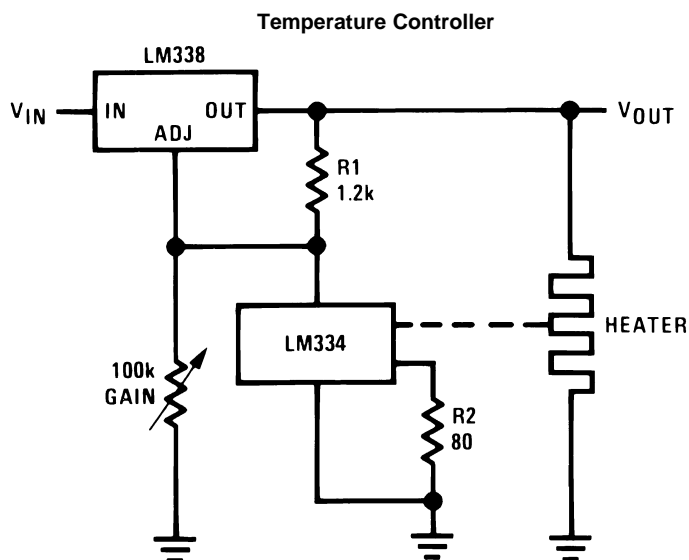
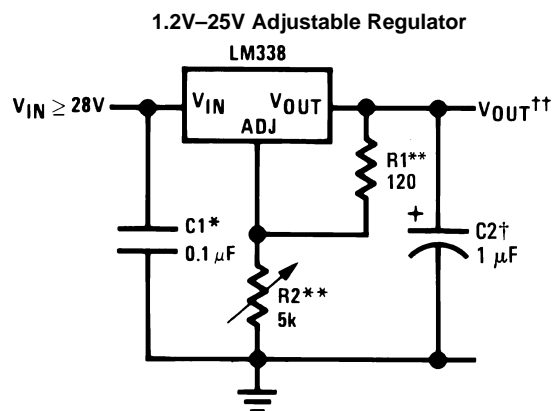
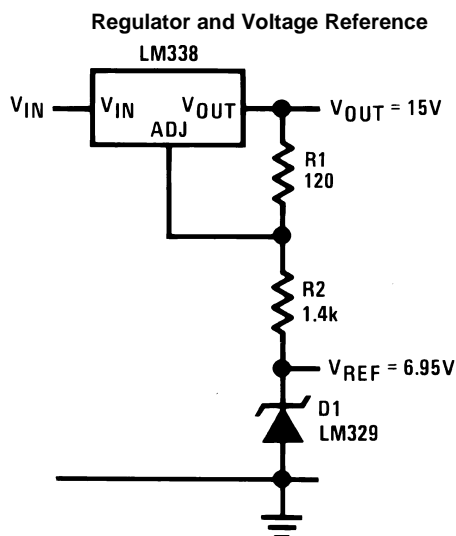

Full output current not available at high input-output voltages

†Optional—improves transient response. Output capacitors in the range of 1 μF to 1000 μF of aluminum or tantalum electrolytic are commonly used to provide improved output impedance and rejection of transients.

*Needed if device is more than 6 inches from filter capacitors.

$$\dagger\dagger V_{\text{OUT}} = 1.25\text{V} \left(1 + \frac{R_2}{R_1} \right) + I_{\text{ADJ}} (R_2)$$

**R1 = 240 Ω for LM138. R1, R2 as an assembly can be ordered from Bourns:

MIL part no. 7105A-AT2-502

COMM part no. 7105A-AT7-502

Schematic Diagram

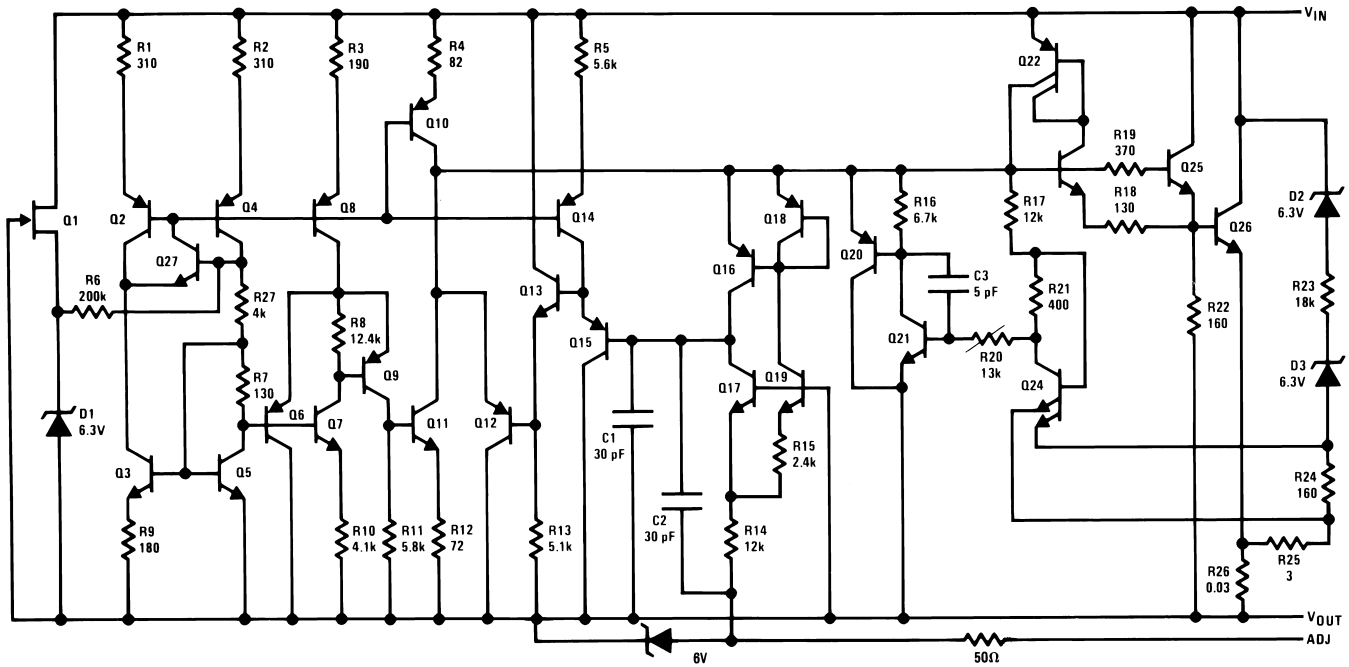

Typical Applications

Precision Power Regulator with Low Temperature Coefficient

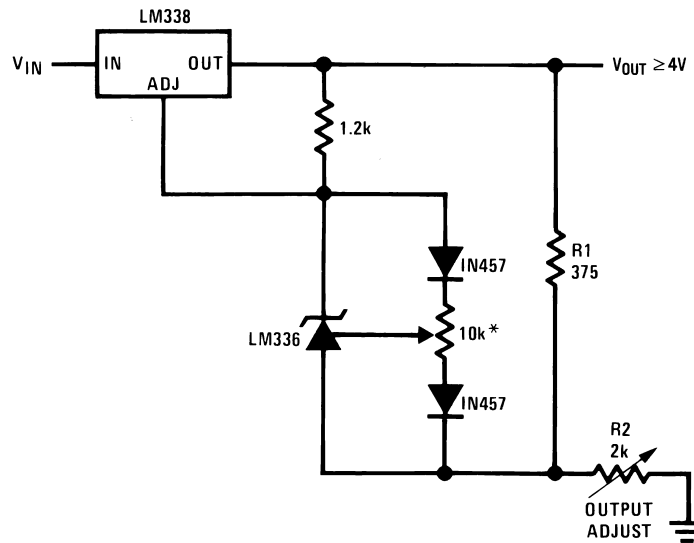

* Adjust for 3.75 across R1

Slow Turn-On 15V Regulator

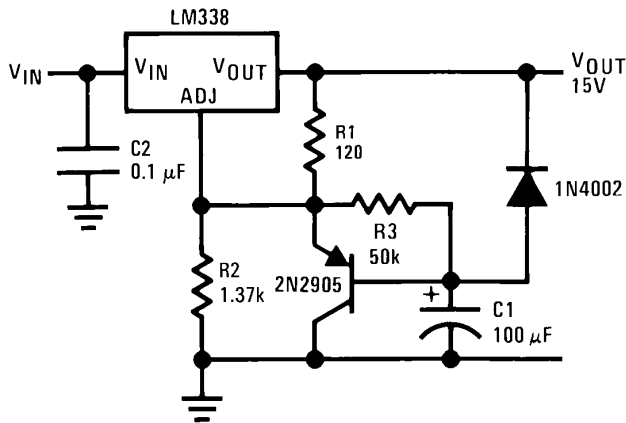

Adjustable Regulator with Improved Ripple Rejection

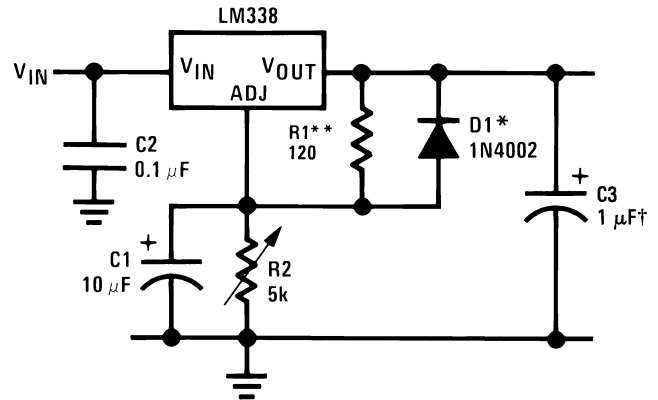

†Solid tantalum

*Discharges C1 if output is shorted to ground

**R1 = 240Ω for LM138

High Stability 10V Regulator

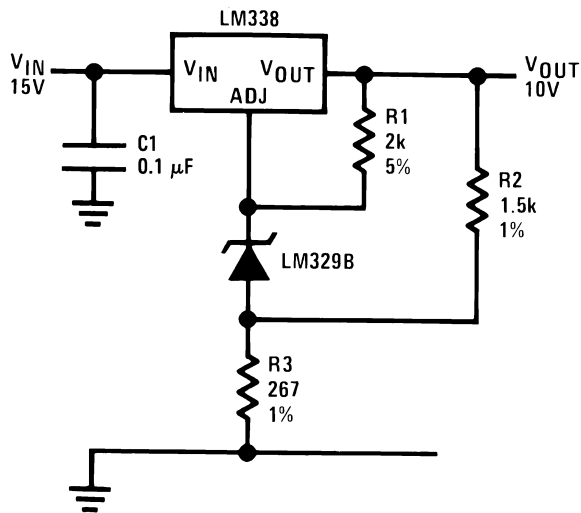

Digitally Selected Outputs

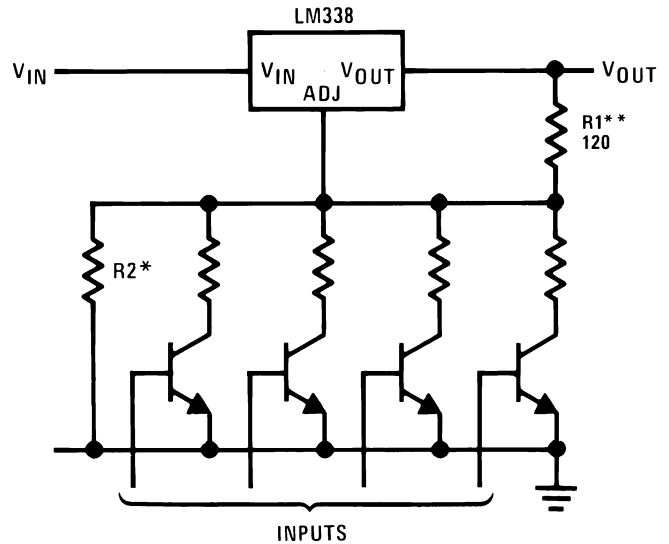

*Sets maximum V_{OUT}

**R1 = 240Ω for LM138

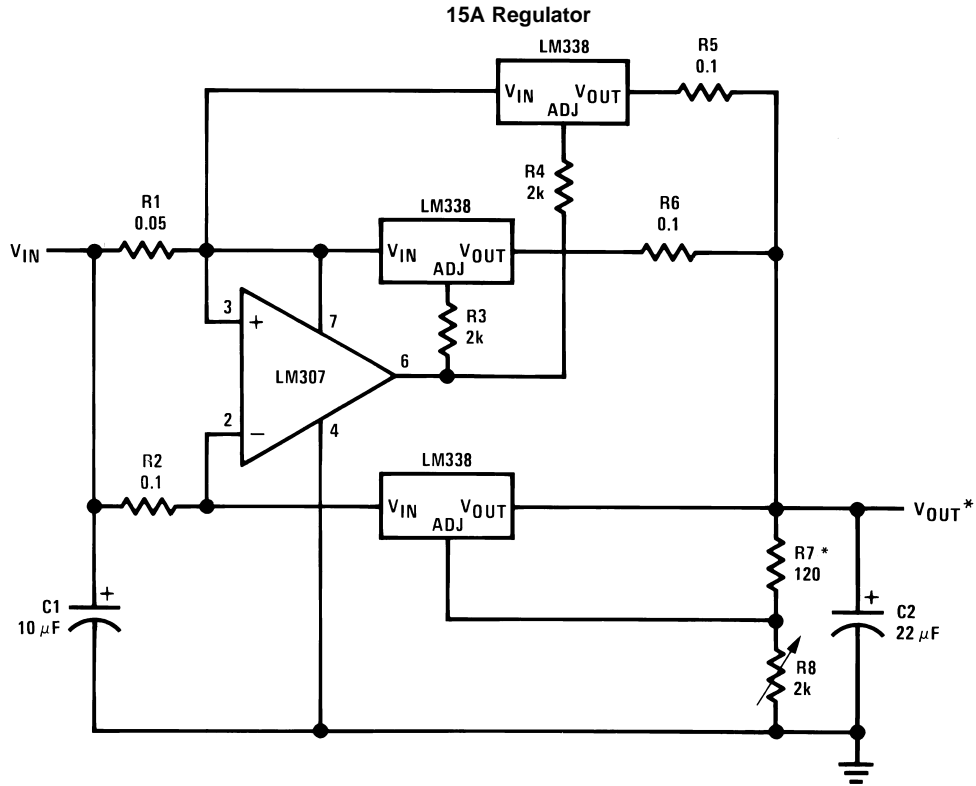

* Minimum load—100 mA

5V Logic Regulator with Electronic Shutdown**

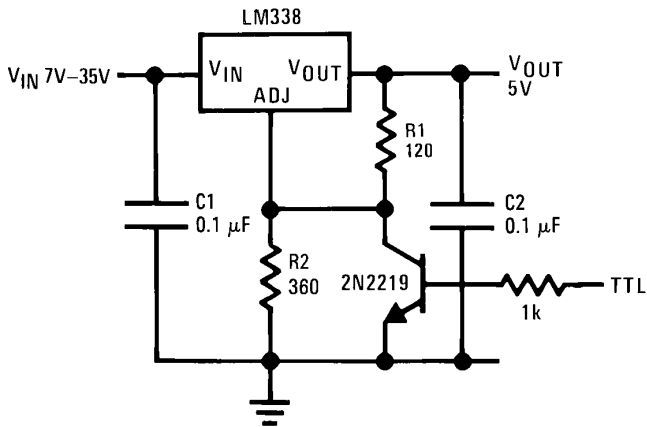

** Minimum output \approx 1.2V

Light Controller

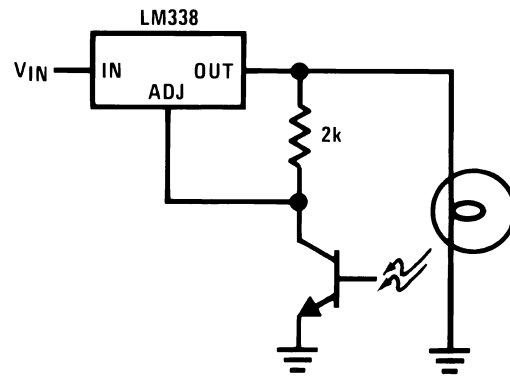

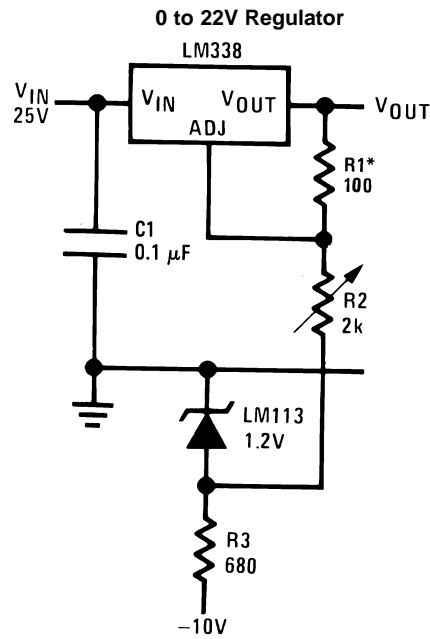

* R1 = 240Ω, R2 = 5k for LM138
 Full output current not available at high input-output voltages

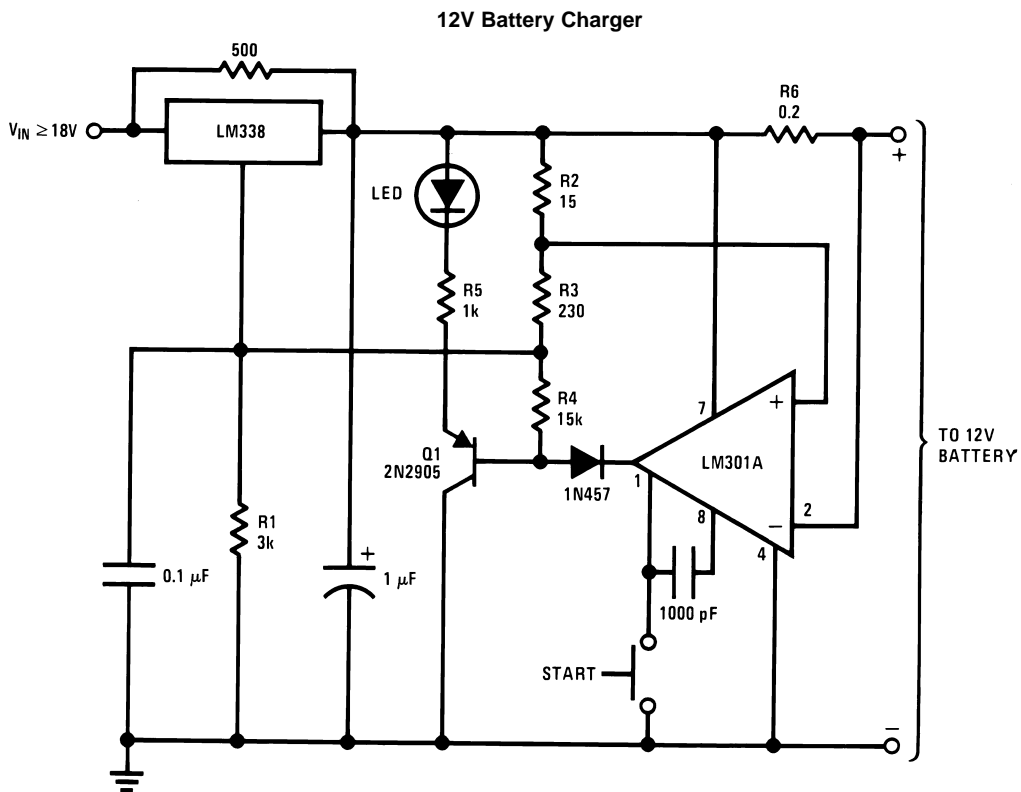

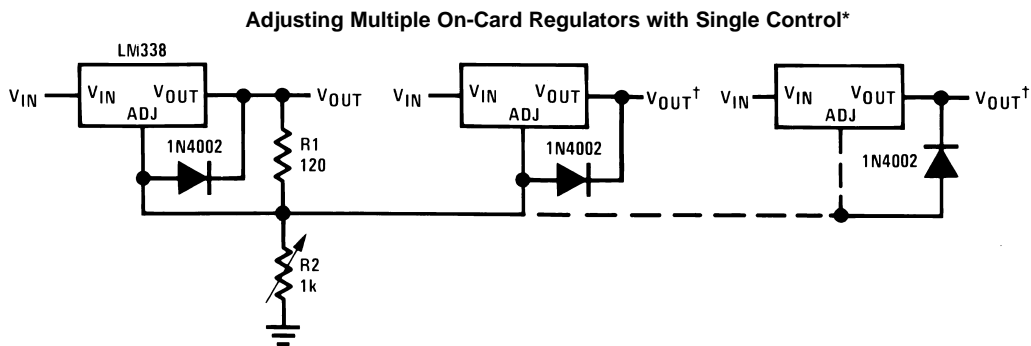
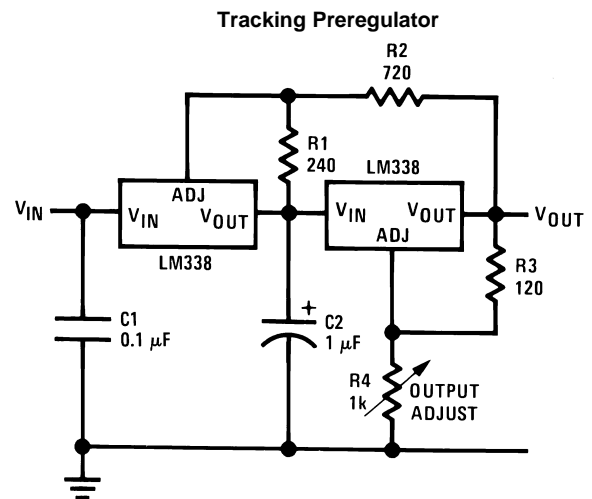
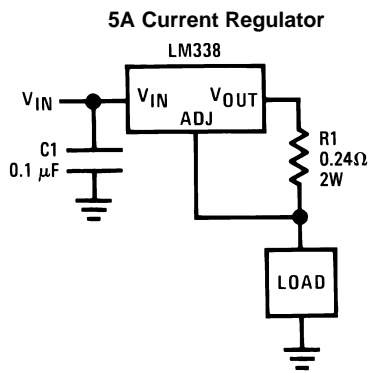
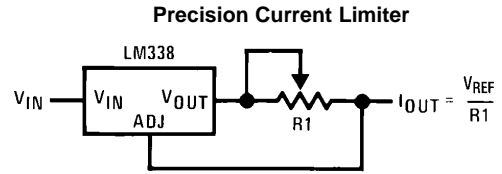
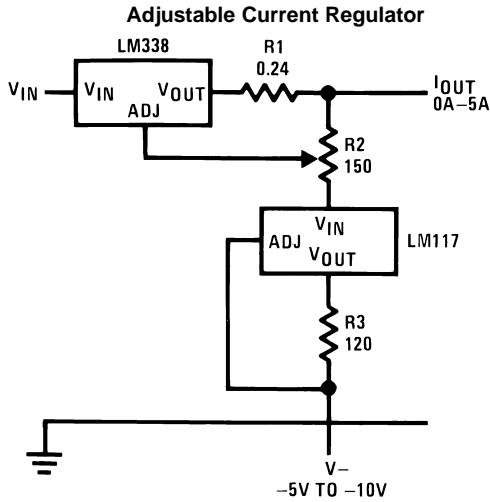

† Minimum load—10 mA
 * All outputs within ±100 mV

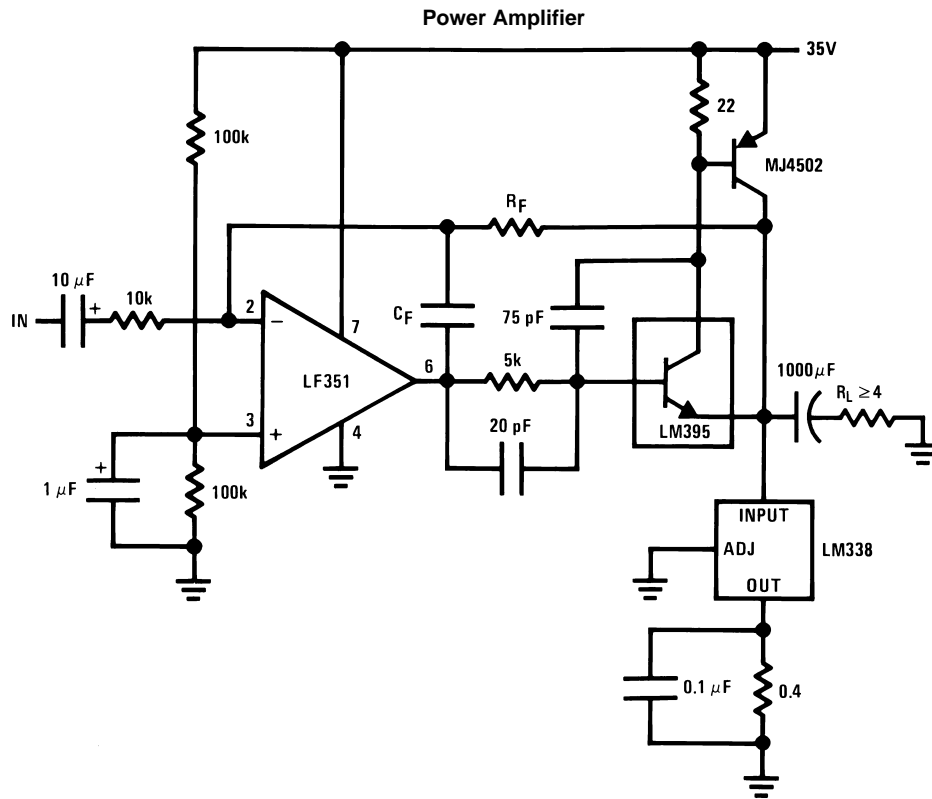

$A_V = 1$, $R_F = 10k$, $C_F = 100 \text{ pF}$
 $A_V = 10$, $R_F = 100k$, $C_F = 10 \text{ pF}$
 Bandwidth $\geq 100 \text{ kHz}$
 Distortion $\leq 0.1\%$

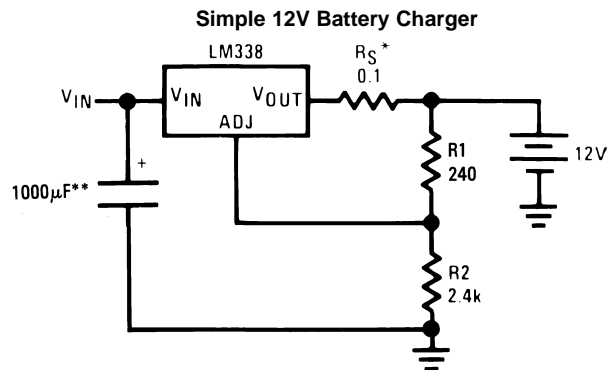

* R_S —sets output impedance of charger $Z_{OUT} = R_S \left(1 + \frac{R_2}{R_1} \right)$

Use of R_S allows low charging rates with fully charged battery.

**The 1000 μF is recommended to filter out input transients

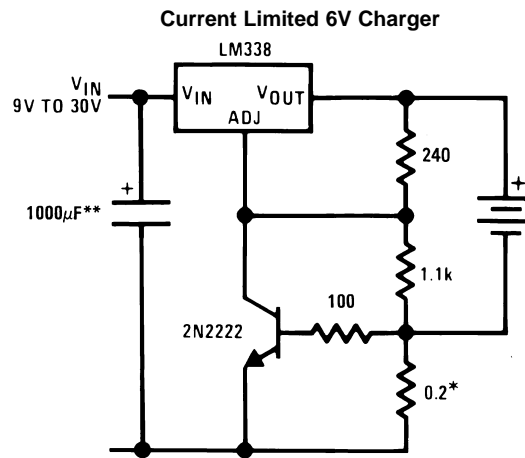
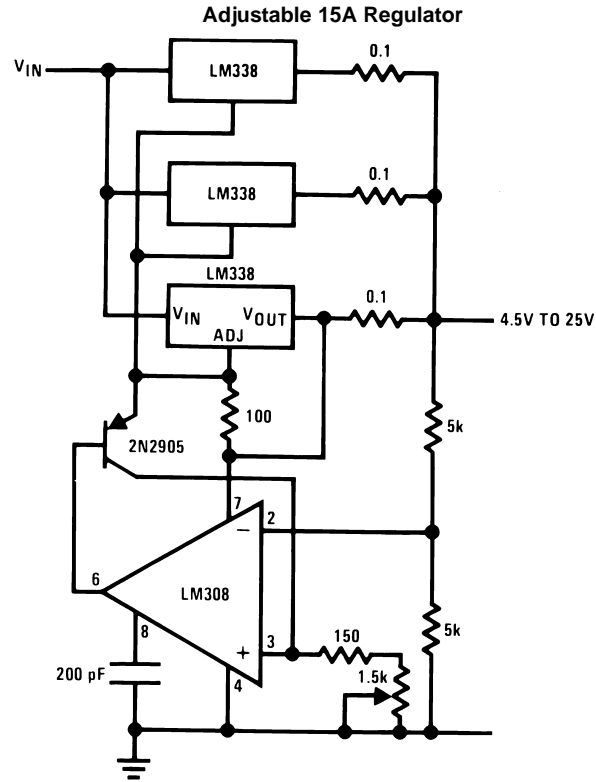

* Set max charge current to 3A

** THE 1000 μF is recommended to filter out input transients.

10A Regulator

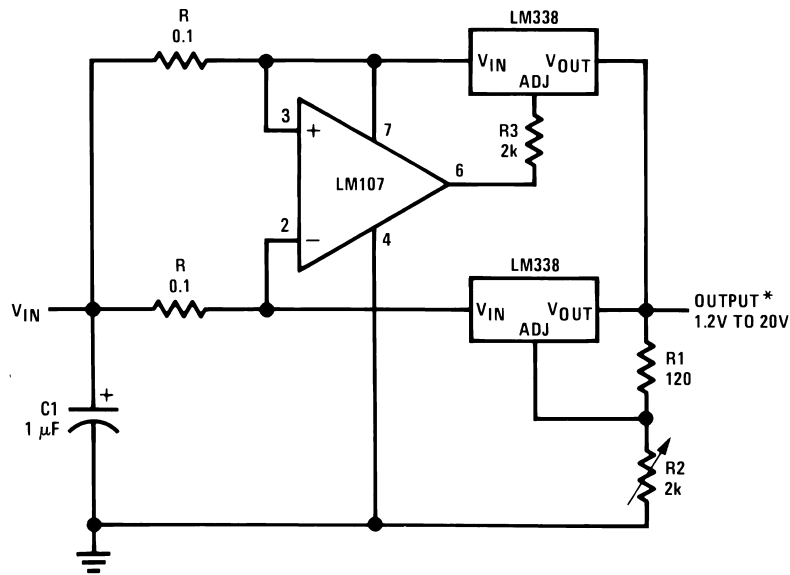

* Minimum load—100 mA

REVISION HISTORY

Changes from Revision A (April 2013) to Revision B	Page
• Changed layout of National Data Sheet to TI format	17

PACKAGING INFORMATION

Orderable Device	Status (1)	Package Type	Package Drawing	Pins	Package Qty	Eco Plan (2)	Lead/Ball Finish (6)	MSL Peak Temp (3)	Op Temp (°C)	Device Marking (4/5)	Samples
LM138K STEEL	ACTIVE	TO-3	NDS	2	50	TBD	Call TI	Call TI	-55 to 125	LM138K STEELP+	Samples
LM138K STEEL/NOPB	ACTIVE	TO-3	NDS	2	50	Green (RoHS & no Sb/Br)	Call TI	Level-1-NA-UNLIM	-55 to 125	LM138K STEELP+	Samples
LM338 MWC	ACTIVE	WAFERSALE	YS	0	1	Green (RoHS & no Sb/Br)	Call TI	Level-1-NA-UNLIM			Samples
LM338K STEEL	ACTIVE	TO-3	NDS	2	50	TBD	Call TI	Call TI	0 to 125	LM338K STEELP+	Samples
LM338K STEEL/NOPB	ACTIVE	TO-3	NDS	2	50	Green (RoHS & no Sb/Br)	Call TI	Level-1-NA-UNLIM	0 to 125	LM338K STEELP+	Samples
LM338T	NRND	TO-220	NDE	3	45	TBD	Call TI	Call TI	0 to 125	LM338T P+	
LM338T/NOPB	ACTIVE	TO-220	NDE	3	45	Green (RoHS & no Sb/Br)	CU SN	Level-1-NA-UNLIM	0 to 125	LM338T P+	Samples

(1) The marketing status values are defined as follows:

ACTIVE: Product device recommended for new designs.

LIFEBUY: TI has announced that the device will be discontinued, and a lifetime-buy period is in effect.

NRND: Not recommended for new designs. Device is in production to support existing customers, but TI does not recommend using this part in a new design.

PREVIEW: Device has been announced but is not in production. Samples may or may not be available.

OBSELETE: TI has discontinued the production of the device.

(2) Eco Plan - The planned eco-friendly classification: Pb-Free (RoHS), Pb-Free (RoHS Exempt), or Green (RoHS & no Sb/Br) - please check <http://www.ti.com/productcontent> for the latest availability information and additional product content details.

TBD: The Pb-Free/Green conversion plan has not been defined.

Pb-Free (RoHS): TI's terms "Lead-Free" or "Pb-Free" mean semiconductor products that are compatible with the current RoHS requirements for all 6 substances, including the requirement that lead not exceed 0.1% by weight in homogeneous materials. Where designed to be soldered at high temperatures, TI Pb-Free products are suitable for use in specified lead-free processes.

Pb-Free (RoHS Exempt): This component has a RoHS exemption for either 1) lead-based flip-chip solder bumps used between the die and package, or 2) lead-based die adhesive used between the die and leadframe. The component is otherwise considered Pb-Free (RoHS compatible) as defined above.

Green (RoHS & no Sb/Br): TI defines "Green" to mean Pb-Free (RoHS compatible), and free of Bromine (Br) and Antimony (Sb) based flame retardants (Br or Sb do not exceed 0.1% by weight in homogeneous material)

(3) MSL, Peak Temp. - The Moisture Sensitivity Level rating according to the JEDEC industry standard classifications, and peak solder temperature.

(4) There may be additional marking, which relates to the logo, the lot trace code information, or the environmental category on the device.

⁽⁵⁾ Multiple Device Markings will be inside parentheses. Only one Device Marking contained in parentheses and separated by a "-" will appear on a device. If a line is indented then it is a continuation of the previous line and the two combined represent the entire Device Marking for that device.

⁽⁶⁾ Lead/Ball Finish - Orderable Devices may have multiple material finish options. Finish options are separated by a vertical ruled line. Lead/Ball Finish values may wrap to two lines if the finish value exceeds the maximum column width.

Important Information and Disclaimer:The information provided on this page represents TI's knowledge and belief as of the date that it is provided. TI bases its knowledge and belief on information provided by third parties, and makes no representation or warranty as to the accuracy of such information. Efforts are underway to better integrate information from third parties. TI has taken and continues to take reasonable steps to provide representative and accurate information but may not have conducted destructive testing or chemical analysis on incoming materials and chemicals. TI and TI suppliers consider certain information to be proprietary, and thus CAS numbers and other limited information may not be available for release.

In no event shall TI's liability arising out of such information exceed the total purchase price of the TI part(s) at issue in this document sold by TI to Customer on an annual basis.

NDS0002A

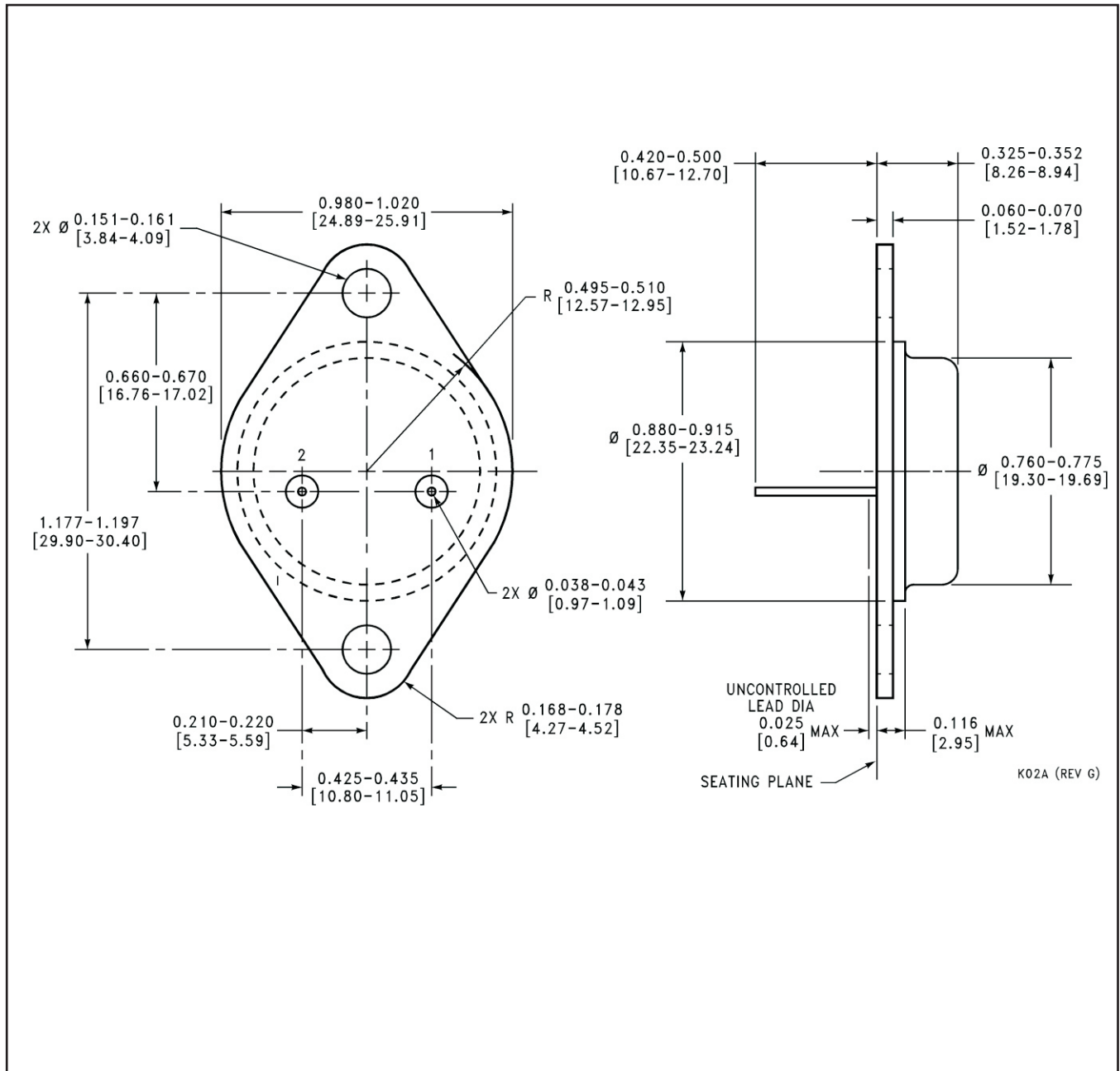

NDE0003B

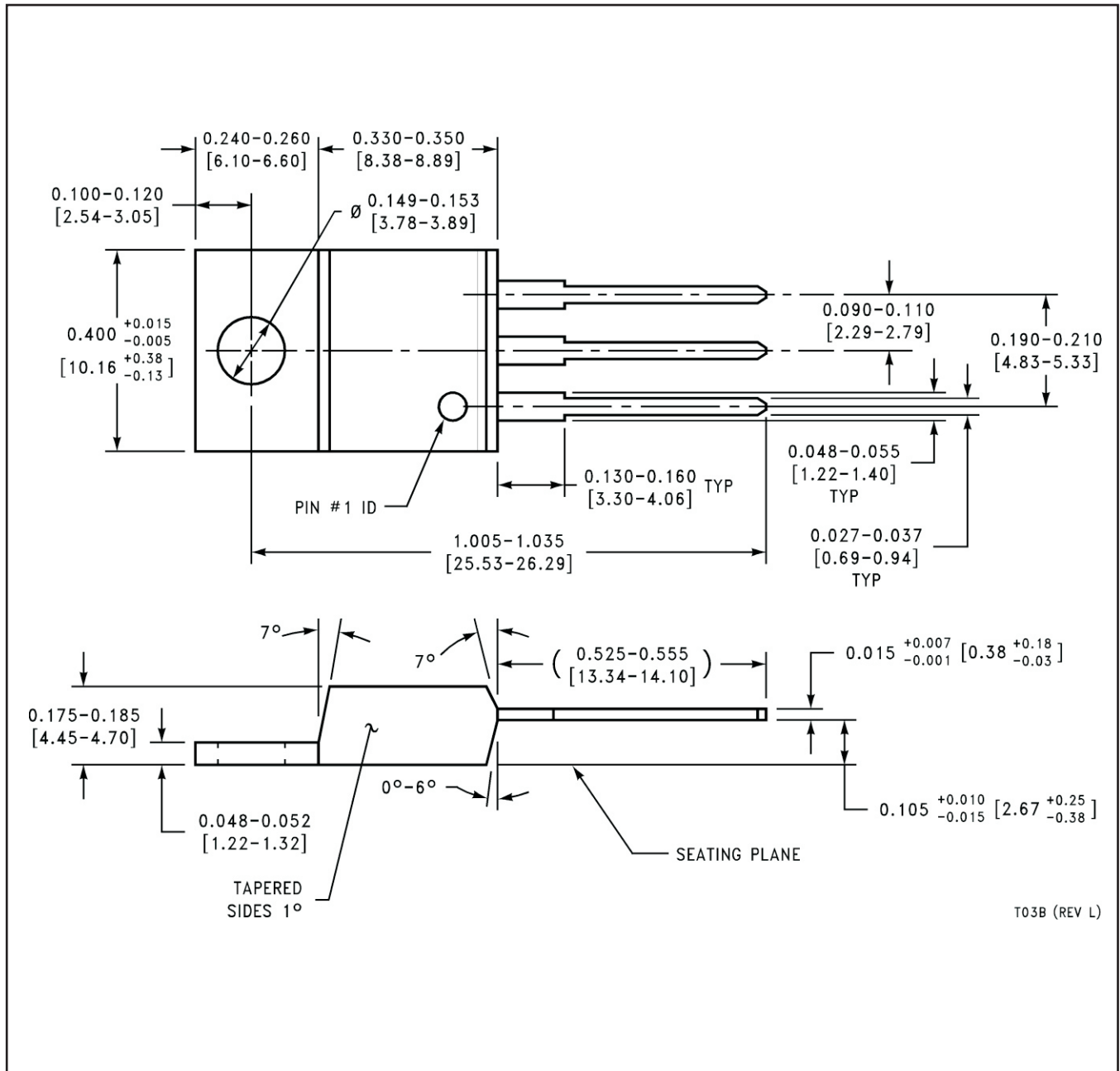

IMPORTANT NOTICE

Texas Instruments Incorporated and its subsidiaries (TI) reserve the right to make corrections, enhancements, improvements and other changes to its semiconductor products and services per JESD46, latest issue, and to discontinue any product or service per JESD48, latest issue. Buyers should obtain the latest relevant information before placing orders and should verify that such information is current and complete. All semiconductor products (also referred to herein as "components") are sold subject to TI's terms and conditions of sale supplied at the time of order acknowledgment.

TI warrants performance of its components to the specifications applicable at the time of sale, in accordance with the warranty in TI's terms and conditions of sale of semiconductor products. Testing and other quality control techniques are used to the extent TI deems necessary to support this warranty. Except where mandated by applicable law, testing of all parameters of each component is not necessarily performed.

TI assumes no liability for applications assistance or the design of Buyers' products. Buyers are responsible for their products and applications using TI components. To minimize the risks associated with Buyers' products and applications, Buyers should provide adequate design and operating safeguards.

TI does not warrant or represent that any license, either express or implied, is granted under any patent right, copyright, mask work right, or other intellectual property right relating to any combination, machine, or process in which TI components or services are used. Information published by TI regarding third-party products or services does not constitute a license to use such products or services or a warranty or endorsement thereof. Use of such information may require a license from a third party under the patents or other intellectual property of the third party, or a license from TI under the patents or other intellectual property of TI.

Reproduction of significant portions of TI information in TI data books or data sheets is permissible only if reproduction is without alteration and is accompanied by all associated warranties, conditions, limitations, and notices. TI is not responsible or liable for such altered documentation. Information of third parties may be subject to additional restrictions.

Resale of TI components or services with statements different from or beyond the parameters stated by TI for that component or service voids all express and any implied warranties for the associated TI component or service and is an unfair and deceptive business practice. TI is not responsible or liable for any such statements.

Buyer acknowledges and agrees that it is solely responsible for compliance with all legal, regulatory and safety-related requirements concerning its products, and any use of TI components in its applications, notwithstanding any applications-related information or support that may be provided by TI. Buyer represents and agrees that it has all the necessary expertise to create and implement safeguards which anticipate dangerous consequences of failures, monitor failures and their consequences, lessen the likelihood of failures that might cause harm and take appropriate remedial actions. Buyer will fully indemnify TI and its representatives against any damages arising out of the use of any TI components in safety-critical applications.

In some cases, TI components may be promoted specifically to facilitate safety-related applications. With such components, TI's goal is to help enable customers to design and create their own end-product solutions that meet applicable functional safety standards and requirements. Nonetheless, such components are subject to these terms.

No TI components are authorized for use in FDA Class III (or similar life-critical medical equipment) unless authorized officers of the parties have executed a special agreement specifically governing such use.

Only those TI components which TI has specifically designated as military grade or "enhanced plastic" are designed and intended for use in military/aerospace applications or environments. Buyer acknowledges and agrees that any military or aerospace use of TI components which have **not** been so designated is solely at the Buyer's risk, and that Buyer is solely responsible for compliance with all legal and regulatory requirements in connection with such use.

TI has specifically designated certain components as meeting ISO/TS16949 requirements, mainly for automotive use. In any case of use of non-designated products, TI will not be responsible for any failure to meet ISO/TS16949.

Products

Audio	www.ti.com/audio
Amplifiers	amplifier.ti.com
Data Converters	dataconverter.ti.com
DLP® Products	www.dlp.com
DSP	dsp.ti.com
Clocks and Timers	www.ti.com/clocks
Interface	interface.ti.com
Logic	logic.ti.com
Power Mgmt	power.ti.com
Microcontrollers	microcontroller.ti.com
RFID	www.ti-rfid.com
OMAP Applications Processors	www.ti.com/omap
Wireless Connectivity	www.ti.com/wirelessconnectivity

Applications

Automotive and Transportation	www.ti.com/automotive
Communications and Telecom	www.ti.com/communications
Computers and Peripherals	www.ti.com/computers
Consumer Electronics	www.ti.com/consumer-apps
Energy and Lighting	www.ti.com/energy
Industrial	www.ti.com/industrial
Medical	www.ti.com/medical
Security	www.ti.com/security
Space, Avionics and Defense	www.ti.com/space-avionics-defense
Video and Imaging	www.ti.com/video

TI E2E Community

e2e.ti.com