

# 12-Bit Differential Input Micro Power Sampling ANALOG-TO-DIGITAL CONVERTER

## FEATURES

- BIPOLAR INPUT RANGE
- TRUE DIFFERENTIAL INPUT
- 200kHz SAMPLING RATE
- MICRO POWER: 2.3mW at 200kHz
- POWER DOWN: 3μA Max
- AVAILABLE IN MSOP-8 PACKAGE
- SERIAL INTERFACE
- AC COMMON-MODE REJECTION

## APPLICATIONS

- TRANSDUCER INTERFACE
- BATTERY OPERATED SYSTEMS
- REMOTE DATA ACQUISITION
- ISOLATED DATA ACQUISITION
- AC MOTOR CONTROL

## DESCRIPTION

The ADS7817 is a 12-bit, 200kHz sampling Analog-to-Digital (A/D) converter that features a high impedance fully differential analog input. The reference voltage can be varied from 100mV to 2.5V, with a corresponding input-referred resolution between 49μV and 1.22mV.

The differential input, low power, automatic power down, and small size make the ADS7817 ideal for direct connection to transducers in battery operated systems, remote data acquisition, or multi-channel applications. The ADS7817 is available in a plastic mini-DIP-8, an SO-8, or an MSOP-8 package.

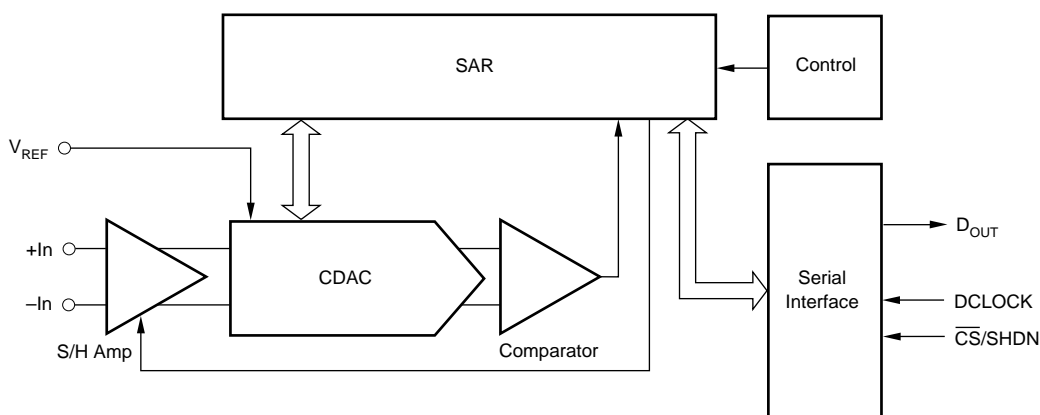

Please be aware that an important notice concerning availability, standard warranty, and use in critical applications of Texas Instruments semiconductor products and disclaimers thereto appears at the end of this data sheet.

## ABSOLUTE MAXIMUM RATINGS<sup>(1)</sup>

+V <sub>CC</sub> .....	+6V
Analog Input .....	-0.3V to (+V <sub>CC</sub> + 0.3V)
Logic Input .....	-0.3V to (+V <sub>CC</sub> + 0.3V)
Case Temperature .....	+100°C
Junction Temperature .....	+150°C
Storage Temperature .....	+125°C
External Reference Voltage .....	+5.5V

NOTE: (1) Stresses above these ratings may permanently damage the device.



## ELECTROSTATIC DISCHARGE SENSITIVITY

This integrated circuit can be damaged by ESD. Texas Instruments recommends that all integrated circuits be handled with appropriate precautions. Failure to observe proper handling and installation procedures can cause damage.

ESD damage can range from subtle performance degradation to complete device failure. Precision integrated circuits may be more susceptible to damage because very small parametric changes could cause the device not to meet its published specifications.

## PIN CONFIGURATION

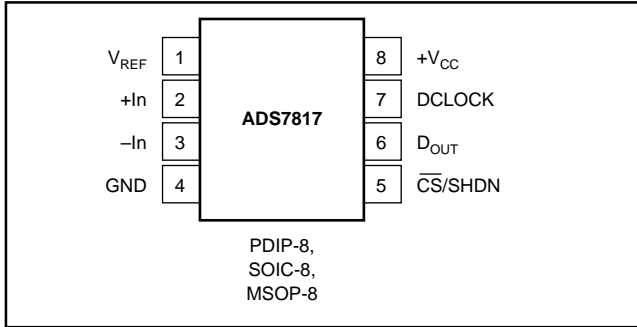

## PIN DESCRIPTIONS

PIN	NAME	DESCRIPTION
1	V <sub>REF</sub>	Reference Input.
2	+In	Non Inverting Input.
3	-In	Inverting Input.
4	GND	Ground.
5	$\overline{\text{CS}}/\text{SHDN}$	Chip Select when LOW, Shutdown Mode when HIGH.
6	D <sub>OUT</sub>	The serial output data word is comprised of 12 bits of data. In operation the data is valid on the falling edge of DCLOCK. The second clock pulse after the falling edge of CS enables the serial output. After one null bit the data is valid for the next 12 edges.
7	DCLOCK	Data Clock synchronizes the serial data transfer and determines conversion speed.
8	+V <sub>CC</sub>	Power Supply.

## PACKAGE/ORDERING INFORMATION

PRODUCT	MAXIMUM INTEGRAL LINEARITY ERROR (LSB)	MAXIMUM DIFFERENTIAL LINEARITY ERROR (LSB)	PACKAGE	PACKAGE DRAWING NUMBER <sup>(1)</sup>	SPECIFICATION TEMPERATURE RANGE	PACKAGE MARKING <sup>(2)</sup>	ORDERING NUMBER <sup>(3)</sup>	TRANSPORT MEDIA
ADS7817P	±2	±2	DIP-8	006	-40°C to +85°C	ADS7817P	ADS7817P	Rails
ADS7817U	±2	±2	SO-8	182	-40°C to +85°C	ADS7817U	ADS7817U	"
ADS7817E	±2	±2	MSOP-8	337	-40°C to +85°C	A17	ADS7817U/2K5	Tape and Reel
ADS7817E	"	"	"	"	"	"	ADS7817E	Rails
ADS7817E	"	"	"	"	"	"	ADS7817E/250	Tape and Reel
ADS7817E	"	"	"	"	"	"	ADS7817E/2K5	"
ADS7817PB	±2	±1	Plastic DIP-8	006	-40°C to +85°C	ADS7817PB	ADS7817PB	Rails
ADS7817UB	±2	±1	SO-8	182	-40°C to +85°C	ADS7817UB	ADS7817UB	"
ADS7817UB	"	"	"	"	"	"	ADS7817UB/2K5	Tape and Reel
ADS7817EB	±2	±1	MSOP	337	-40°C to +85°C	A17	ADS7817EB	Rails
ADS7817EB	"	"	"	"	"	"	ADS7817EB/250	Tape and Reel
ADS7817EB	"	"	"	"	"	"	ADS7817EB/2K5	"
ADS7817PC	±1	±0.75	DIP-8	006	-40°C to +85°C	ADS7817PC	ADS7817PC	Rails
ADS7817UC	±1	±0.75	SO-8	182	-40°C to +85°C	ADS7817UC	ADS7817UC	"
ADS7817UC	"	"	"	"	"	"	ADS7817UC/2K5	Tape and Reel
ADS7817EC	±1	±0.75	MSOP-8	337	-40°C to +85°C	A17	ADS7817EC	Rails
ADS7817EC	"	"	"	"	"	"	ADS7817EC/250	Tape and Reel
ADS7817EC	"	"	"	"	"	"	ADS7817EC/2K5	"

NOTE: (1) For detail drawing and dimension table, please see end of data sheet or Package Drawing File on Web. (2) Performance Grade information is marked on the reel. (3) Models with a slash(/) are available only in Tape and reel in quantities indicated (e.g. /250 indicates 250 units per reel, /2K5 indicates 2500 devices per reel). Ordering 2500 pieces of "ADS7817E/2K5" will get a single 2500-piece Tape and Reel.

# ELECTRICAL CHARACTERISTICS

At  $-40^{\circ}\text{C}$  to  $+85^{\circ}\text{C}$ ,  $+V_{\text{CC}} = +5\text{V}$ ,  $V_{\text{REF}} = +2.5\text{V}$ ,  $f_{\text{SAMPLE}} = 200\text{kHz}$ ,  $f_{\text{CLK}} = 16 \cdot f_{\text{SAMPLE}}$ ,  $-\text{In} = +2.5\text{V}$ , unless otherwise specified.

PARAMETER	CONDITIONS	ADS7817			ADS7817B			ADS7817C			UNITS
		MIN	TYP	MAX	MIN	TYP	MAX	MIN	TYP	MAX	
<b>ANALOG INPUT</b>											
Full-Scale Input Span	$+\text{In} - (-\text{In})$	$-V_{\text{REF}}$		$+V_{\text{REF}}$	*		*	*		*	V
Absolute Input Voltage	$+\text{In}$	$-0.3$		$V_{\text{CC}} + 0.3$	*		*	*		*	V
	$-\text{In}$	$-0.3$		4	*		*	*		*	V
Capacitance			15			*			*		pF
Leakage Current			$\pm 1$			*			*		$\mu\text{A}$
<b>SYSTEM PERFORMANCE</b>											
Resolution		11	12		12	*		*	*		Bits
No Missing Codes											Bits
Integral Linearity Error			$\pm 1$	$\pm 2$		$\pm 0.8$	$\pm 2$	*	$\pm 0.5$	$\pm 1$	LSB <sup>(1)</sup>
Differential Linearity Error			$\pm 1$	$\pm 2$		$\pm 0.7$	$\pm 1$		$\pm 0.4$	$\pm 1$	LSB
Offset Error			$\pm 1$	$\pm 6$		*	*		*	*	LSB
Gain Error			$\pm 0.5$	$\pm 4$		*	*		*	*	LSB
Noise			63			*			*		$\mu\text{V}_{\text{rms}}$
Common-Mode Rejection			80			*			*		dB
Power Supply Rejection			82			*			*		dB
<b>SAMPLING DYNAMICS</b>											
Conversion Time				12			*			*	Clk Cycles
Acquisition Time		1.5			*			*			Clk Cycles
Throughput Rate				200			*			*	kHz
<b>DYNAMIC CHARACTERISTICS</b>											
Total Harmonic Distortion	$V_{\text{IN}} = 5.0\text{V}_{\text{p-p}}$ at 1kHz		-83			*			*		dB
	$V_{\text{IN}} = 5.0\text{V}_{\text{p-p}}$ at 5kHz		-81			*			*		dB
SINAD	$V_{\text{IN}} = 5.0\text{V}_{\text{p-p}}$ at 1kHz		71			*			*		dB
Spurious Free Dynamic Range	$V_{\text{IN}} = 5.0\text{V}_{\text{p-p}}$ at 1kHz		86			*			*		dB
<b>REFERENCE INPUT</b>											
Voltage Range		0.1		2.5	*		*	*		*	V
Resistance	$\overline{\text{CS}} = V_{\text{CC}}$		5			*			*		$\text{G}\Omega$
	$\overline{\text{CS}} = \text{GND}$ , $f_{\text{SAMPLE}} = 0\text{Hz}$		5			*			*		$\text{G}\Omega$
Current Drain	At Code FF8h		20	100		*	*		*	*	$\mu\text{A}$
	$f_{\text{SAMPLE}} = 12.5\text{kHz}$		1.3	20		*	*		*	*	$\mu\text{A}$
	$\text{CS} = V_{\text{CC}}$		0.001	3		*	*		*	*	$\mu\text{A}$
<b>DIGITAL INPUT/OUTPUT</b>											
Logic Family			CMOS			*			*		
Logic Levels:											
$V_{\text{IH}}$	$I_{\text{IH}} = +5\mu\text{A}$	3		$+V_{\text{CC}} + 0.3$	*		*	*	*	*	V
$V_{\text{IL}}$	$I_{\text{IL}} = +5\mu\text{A}$	-0.3		0.8	*		*	*	*	*	V
$V_{\text{OH}}$	$I_{\text{OH}} = -250\mu\text{A}$	3.5			*		*	*	*	*	V
$V_{\text{OL}}$	$I_{\text{OL}} = 250\mu\text{A}$			0.4			*	*	*	*	V
Data Format			Binary Two's Complement				*	*	*	*	
<b>POWER SUPPLY REQUIREMENTS</b>											
$V_{\text{CC}}$	Specified Performance	4.75		5.25	*		*	*	*	*	V
Quiescent Current			460	800		*	*	*	*	*	$\mu\text{A}$
	$f_{\text{SAMPLE}} = 12.5\text{kHz}$ <sup>(2, 3)</sup>		40			*	*	*	*	*	$\mu\text{A}$
	$f_{\text{SAMPLE}} = 12.5\text{kHz}$ <sup>(3)</sup>		330			*	*	*	*	*	$\mu\text{A}$
Power Down	$\overline{\text{CS}} = V_{\text{CC}}$ , $f_{\text{SAMPLE}} = 0\text{Hz}$			3			*	*	*	*	$\mu\text{A}$
<b>TEMPERATURE RANGE</b>											
Specified Performance		-40		+85	*		*	*	*	*	$^{\circ}\text{C}$

\* Specifications same as ADS7817.

NOTE: (1) LSB means Least Significant Bit, with  $V_{\text{REF}}$  equal to  $+2.5\text{V}$ , one LSB is  $1.22\text{mV}$ . (2)  $f_{\text{CLK}} = 3.2\text{MHz}$ ,  $\overline{\text{CS}} = V_{\text{CC}}$  for 241 clock cycles out of every 256. (3) See the Power Dissipation section for more information regarding lower sample rates.

# TIMING CHARACTERISTICS

At  $T_A = +25^\circ\text{C}$ ,  $V_{CC} = +5\text{V}$ ,  $V_{REF} = +2.5\text{V}$ ,  $f_{SAMPLE} = 200\text{kHz}$ , and  $f_{CLK} = 16 \cdot f_{SAMPLE}$ ,  $-IN = +2.5\text{V}$ , unless otherwise specified.

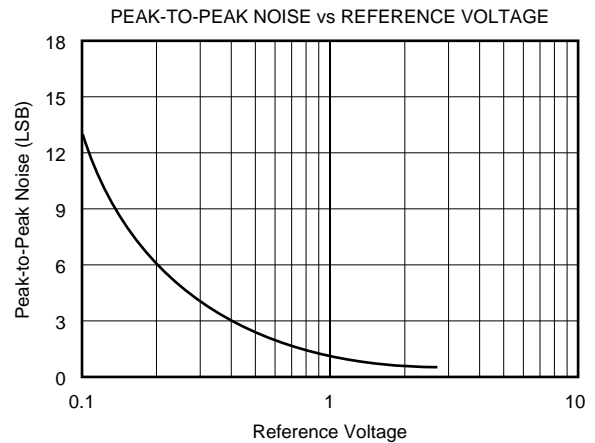
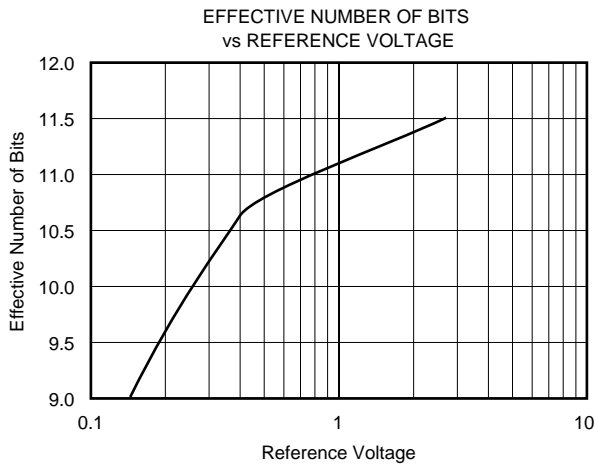
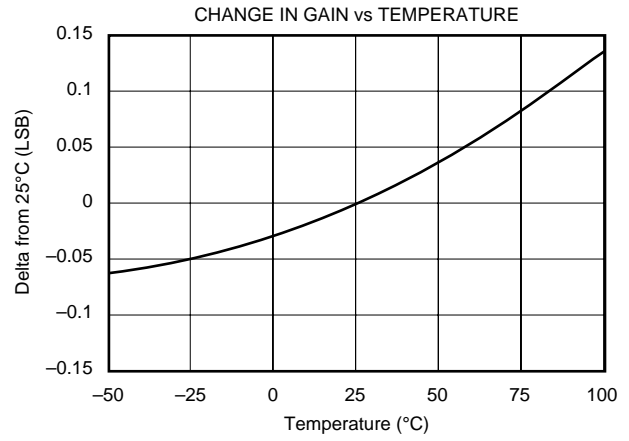
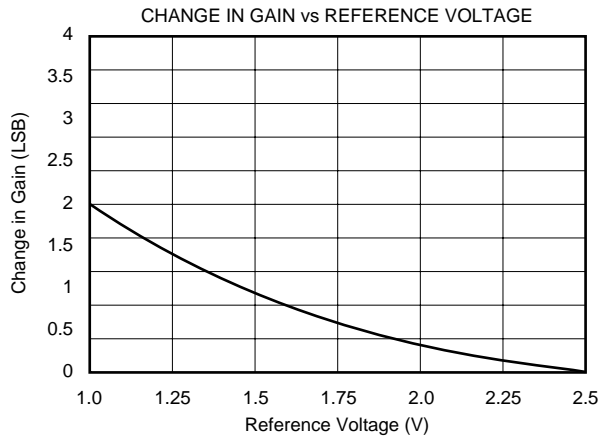
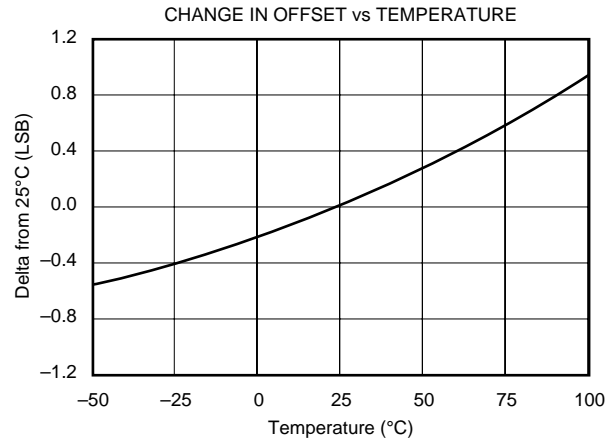
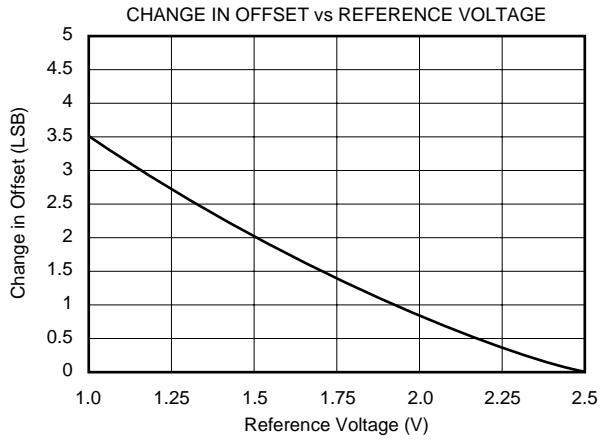

# TIMING CHARACTERISTICS (Cont.)

At  $T_A = +25^\circ\text{C}$ ,  $V_{CC} = +5\text{V}$ ,  $V_{REF} = +2.5\text{V}$ ,  $f_{\text{SAMPLE}} = 200\text{kHz}$ , and  $f_{\text{CLK}} = 16 \cdot f_{\text{SAMPLE}}$ ,  $-I_n = +2.5\text{V}$ , unless otherwise specified.

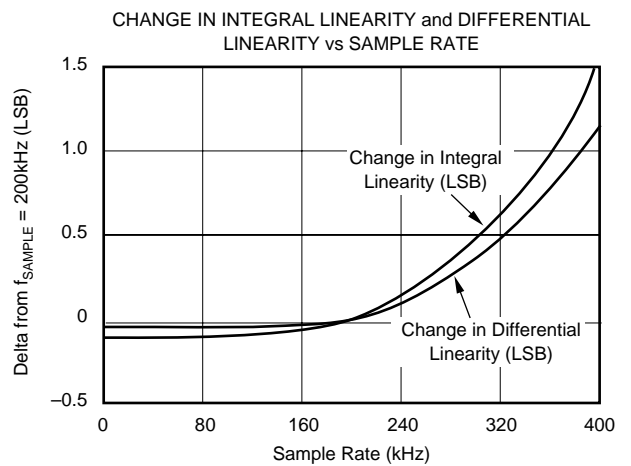
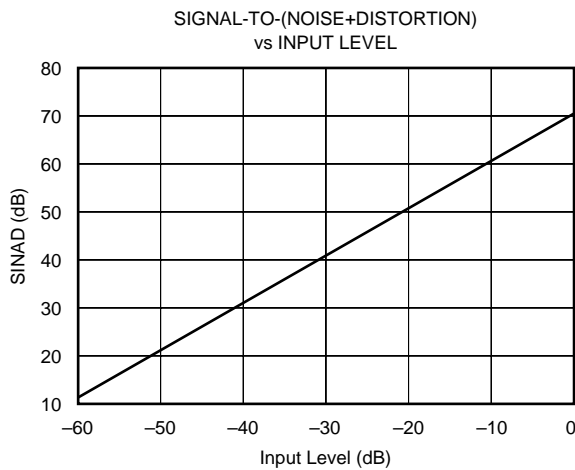
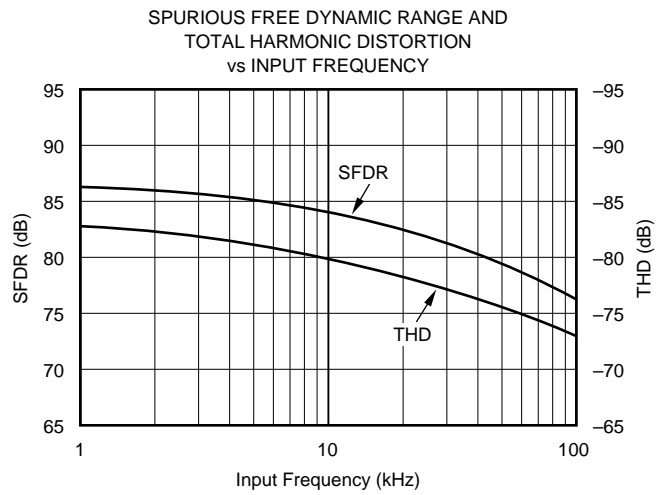
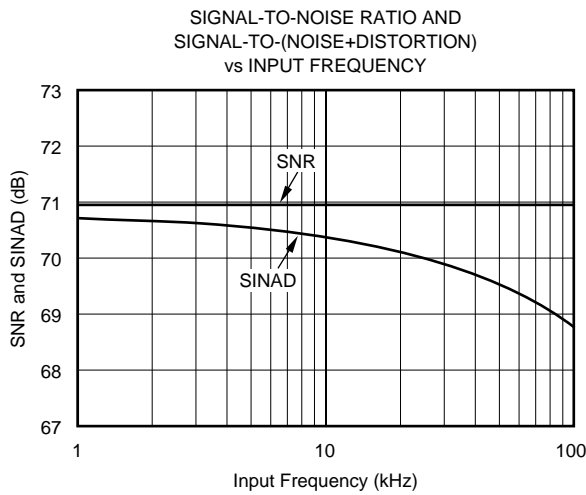
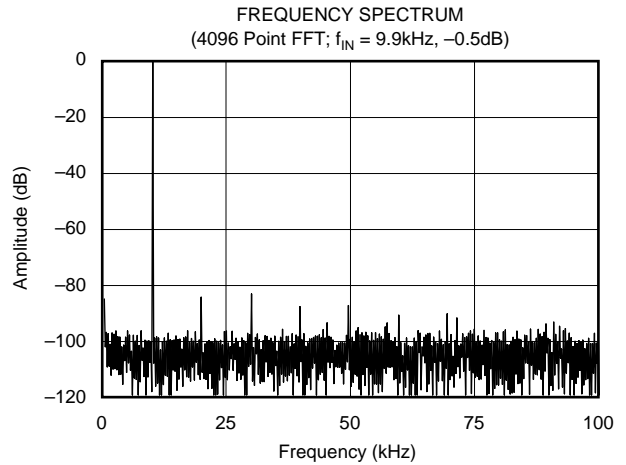
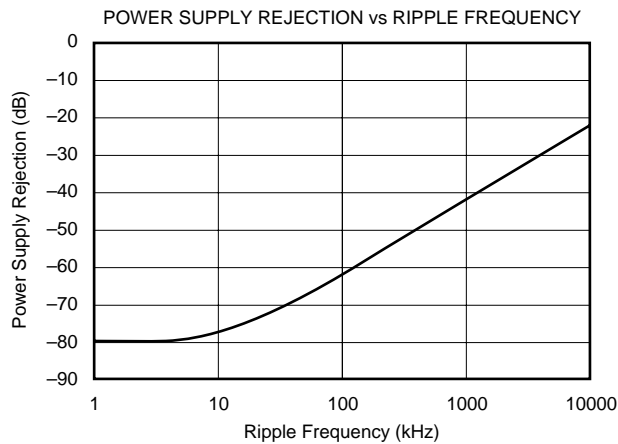

# TIMING CHARACTERISTICS (Cont.)

At  $T_A = +25^\circ\text{C}$ ,  $V_{CC} = +5\text{V}$ ,  $V_{REF} = +2.5\text{V}$ ,  $f_{\text{SAMPLE}} = 200\text{kHz}$ , and  $f_{\text{CLK}} = 16 \cdot f_{\text{SAMPLE}}$ ,  $-I_n = +2.5\text{V}$ , unless otherwise specified.

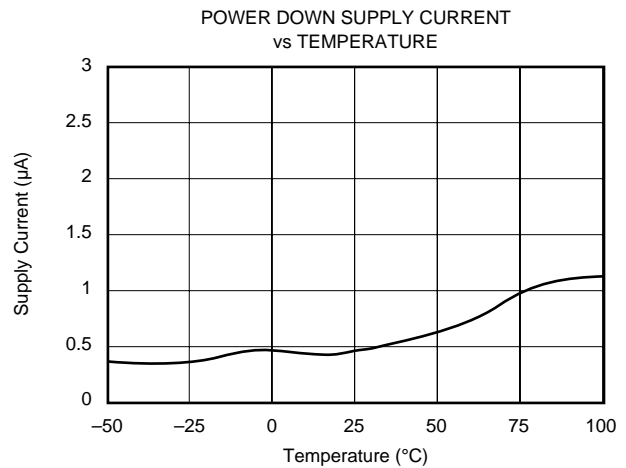
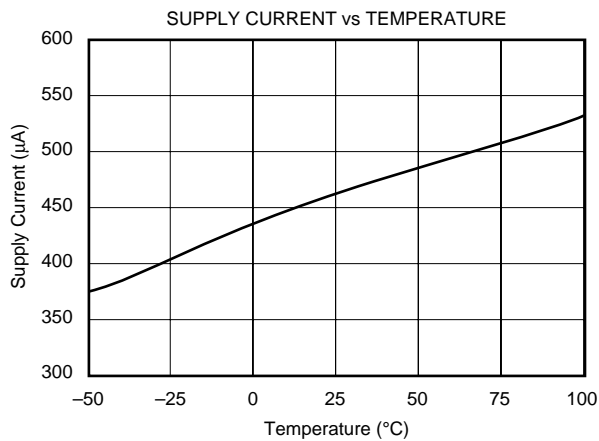
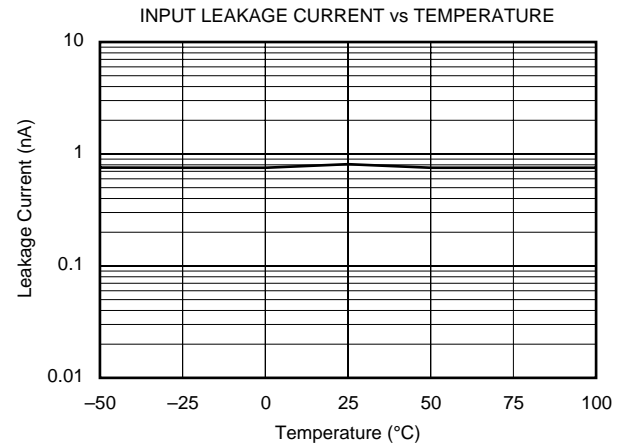
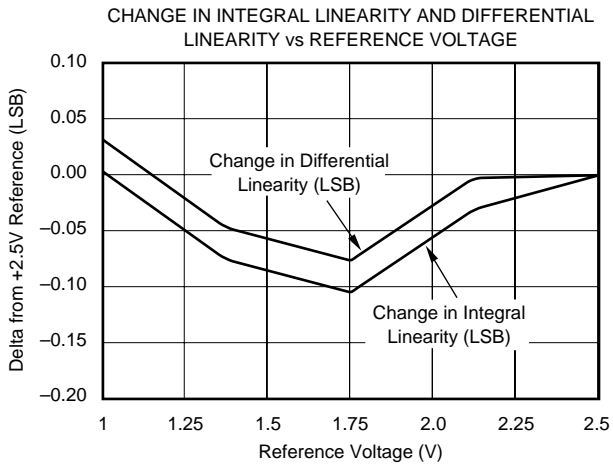
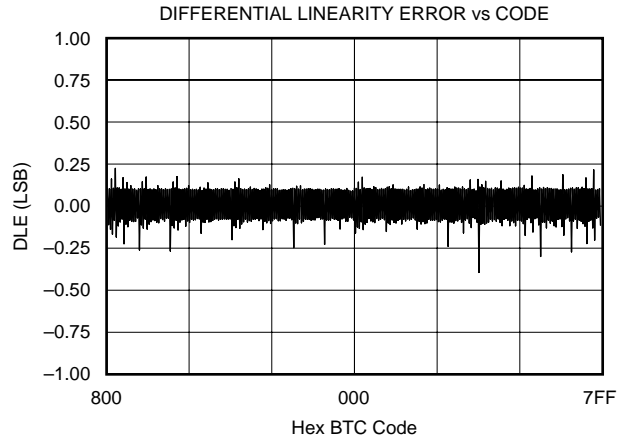
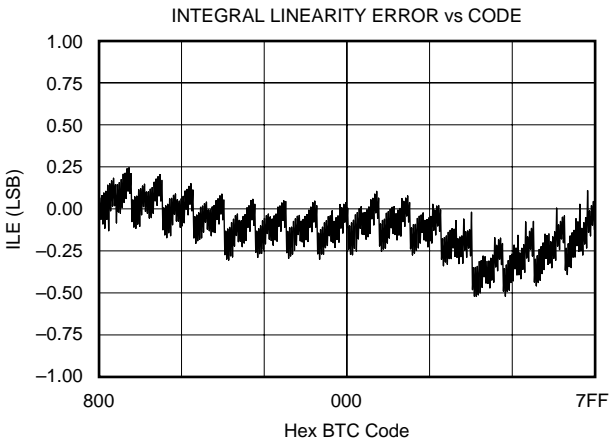

# TIMING CHARACTERISTICS (Cont.)

At  $T_A = +25^\circ\text{C}$ ,  $V_{CC} = +5\text{V}$ ,  $V_{REF} = +2.5\text{V}$ ,  $f_{\text{SAMPLE}} = 200\text{kHz}$ , and  $f_{\text{CLK}} = 16 \cdot f_{\text{SAMPLE}}$ ,  $-IN = +2.5\text{V}$ , unless otherwise specified.

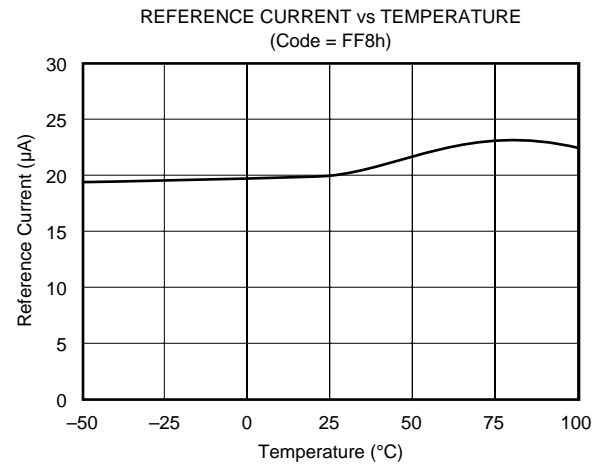
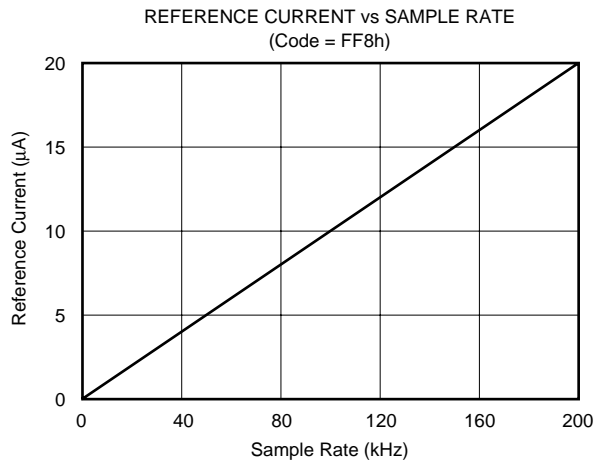

# THEORY OF OPERATION

The ADS7817 is a classic successive approximation register (SAR) analog-to-digital (A/D) converter. The architecture is based on capacitive redistribution which inherently includes a sample/hold function. The converter is fabricated on a 0.6 $\mu$ m CMOS process. The architecture and process allow the ADS7817 to acquire and convert an analog signal at up to 200,000 conversions per second while consuming very little power.

The ADS7817 requires an external reference, an external clock, and a single +5V power source. The external reference can be any voltage between 100mV and 2.5V. The value of the reference voltage directly sets the range of the analog input. The reference input current depends on the conversion rate of the ADS7817.

The external clock can vary between 10kHz (625Hz throughput) and 3.2MHz (200kHz throughput). The duty cycle of the clock is essentially unimportant as long as the minimum high and low times are at least 150ns. The minimum clock frequency is set by the leakage on the capacitors internal to the ADS7817.

The analog input is provided to two input pins: +In and -In. When a conversion is initiated, the differential input on these pins is sampled on the internal capacitor array. While a conversion is in progress, both inputs are disconnected from any internal function.

The digital result of the conversion is clocked out by the DCLOCK input and is provided serially, most significant bit first, on the D<sub>OUT</sub> pin. The digital data that is provided on the D<sub>OUT</sub> pin is for the conversion currently in progress—there is no pipeline delay. It is possible to continue to clock the ADS7817 after the conversion is complete and to obtain the serial data least significant bit first. See the Digital Interface section for more information.

## ANALOG INPUT

The analog input is bipolar and fully differential. There are two general methods of driving the analog input of the ADS7817: single-ended or differential (see Figure 1). When the input is single-ended, the -In input is held at a fixed voltage. The +In input swings around the same voltage and the peak-to-peak amplitude is  $2 \cdot V_{REF}$ . The value of  $V_{REF}$  determines the range over which the common voltage may vary (see Figure 2).

When the input is differential, the amplitude of the input is the difference between the +In and -In input, or: +In - (-In). A voltage or signal is common to both of these inputs. The peak-to-peak amplitude of each input is  $V_{REF}$  about this common voltage. However, since the inputs are 180° out of phase, the peak-to-peak amplitude of the difference voltage is  $2 \cdot V_{REF}$ . The value of  $V_{REF}$  also determines the range of the voltage that may be common to both inputs (see Figure 3).

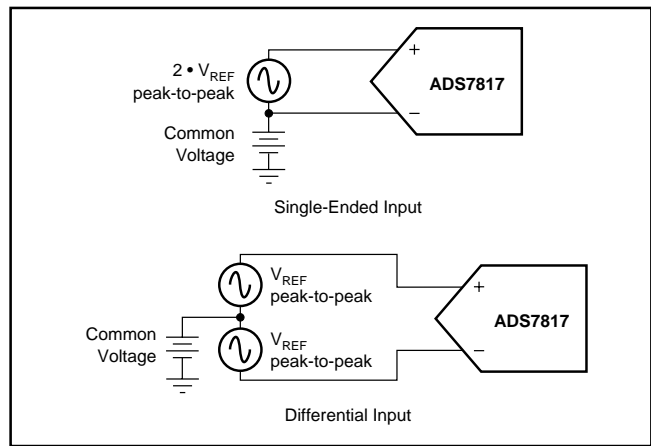

FIGURE 1. Methods of Driving the ADS7817: Single-Ended or Differential.

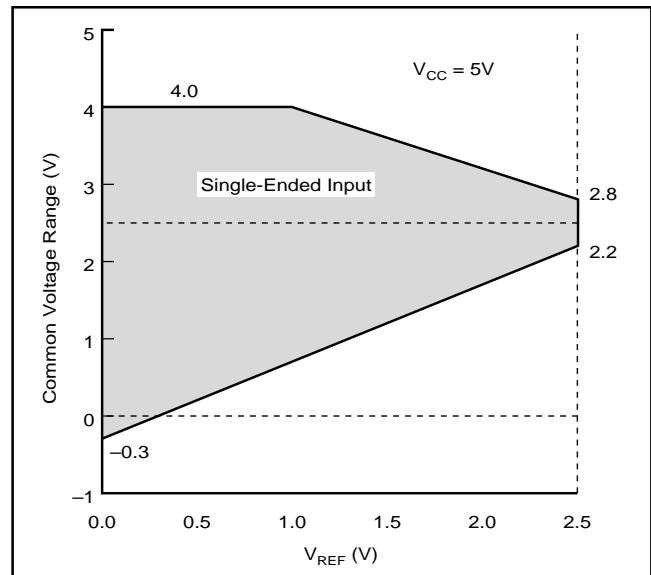

FIGURE 2. Single-Ended Input: Common Voltage Range vs  $V_{REF}$ .

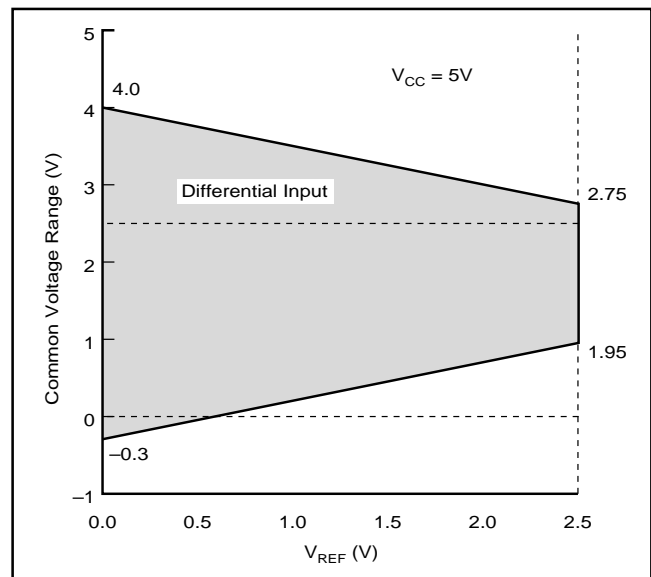

FIGURE 3. Differential Input: Common Voltage Range vs  $V_{REF}$ .

In each case, care should be taken to ensure that the output impedance of the sources driving the +In and –In inputs are matched. If this is not observed, the two inputs could have different settling times. This may result in offset error, gain error, and linearity error which change with both temperature and input voltage. If the impedance cannot be matched, the errors can be lessened by giving the ADS7817 more acquisition time.

The input current on the analog inputs depends on a number of factors: sample rate, input voltage, and source impedance. Essentially, the current into the ADS7817 charges the internal capacitor array during the sample period. After this capacitance has been fully charged, there is no further input current. The source of the analog input voltage must be able to charge the input capacitance (15pF) to a 12-bit settling level within 1.5 clock cycles. When the converter goes into the hold mode or while it is in the power down mode, the input impedance is greater than 1GΩ.

Care must be taken regarding the absolute analog input voltage. The +In input should always remain within the range of GND –300mV to V<sub>CC</sub> +300mV. The –In input should always remain within the range of GND –300mV to 4V. Outside of these ranges, the converter’s linearity may not meet specifications.

## REFERENCE INPUT

The external reference sets the analog input range. The ADS7817 will operate with a reference in the range of 100mV to 2.5V. There are several important implications of this.

As the reference voltage is reduced, the analog voltage weight of each digital output code is reduced. This is often referred to as the LSB (least significant bit) size and is equal to two times the reference voltage divided by 4096. This means that any offset or gain error inherent in the A/D converter will appear to increase, in terms of LSB size, as the reference voltage is reduced. The typical performance curves of “Change in Offset vs Reference Voltage” and “Change in Gain vs Reference Voltage” provide more information.

The noise inherent in the converter will also appear to increase with lower LSB size. With a 2.5V reference, the internal noise of the converter typically contributes only 0.52 LSB peak-to-peak of potential error to the output code. When the external reference is 100mV, the potential error contribution from the internal noise will be 25 times larger—13 LSBs. The errors due to the internal noise are gaussian in nature and can be reduced by averaging consecutive conversion results.

For more information regarding noise, consult the typical performance curves “Effective Number of Bits vs Reference Voltage” and “Peak-to-Peak Noise vs Reference Voltage.” Note that the effective number of bits (ENOB) figure is calculated based on the converter’s signal-to-(noise + distortion) with a 1kHz, 0dB input signal. SINAD is related to ENOB as follows:  $SINAD = 6.02 \cdot ENOB + 1.76$ .

With lower reference voltages, extra care should be taken to provide a clean layout including adequate bypassing, a clean power supply, a low-noise reference, and a low-noise input signal. Because the LSB size is lower, the converter will also be more sensitive to external sources of error such as nearby digital signals and electromagnetic interference.

The current that must be provided by the external reference will depend on the conversion result. The current is lowest at negative full-scale (800h) and is typically 15μA at a 200kHz conversion rate (25°C). For the same conditions, the current will increase as the analog input approaches positive full scale, reaching 25μA at an output result of 7FFh. The current does not increase linearly, but depends, to some degree, on the bit pattern of the digital output.

The reference current diminishes directly with both conversion rate and reference voltage. As the current from the reference is drawn on each bit decision, clocking the converter more quickly during a given conversion period will not reduce the overall current drain from the reference. The reference current changes only slightly with temperature. See the curves, “Reference Current vs Sample Rate” and “Reference Current vs Temperature” in the Typical Performance Curves section for more information.

## DIGITAL INTERFACE

### SERIAL INTERFACE

The ADS7817 communicates with microprocessors and other digital systems via a synchronous 3-wire serial interface as shown in Figure 4 and Table I. The DCLOCK signal synchronizes the data transfer with each bit being transmitted on the falling edge of DCLOCK. Most receiving systems will capture the bitstream on the rising edge of DCLOCK. However, if the minimum hold time for D<sub>OUT</sub> is acceptable, the system can use the falling edge of DCLOCK to capture each bit.

SYMBOL	DESCRIPTION	MIN	TYP	MAX	UNITS
t <sub>SMP</sub>	Analog Input Sample Time	1.5		2.0	Clk Cycles
t <sub>CONV</sub>	Conversion Time		12		Clk Cycles
t <sub>CYC</sub>	Throughput Rate			200	kHz
t <sub>CSD</sub>	$\overline{CS}$ Falling to DCLOCK LOW			0	ns
t <sub>SUCS</sub>	$\overline{CS}$ Falling to DCLOCK Rising	30			ns
t <sub>hDO</sub>	DCLOCK Falling to Current D <sub>OUT</sub> Not Valid	15			ns
t <sub>dDO</sub>	DCLOCK Falling to Next D <sub>OUT</sub> Valid		85	150	ns
t <sub>dis</sub>	$\overline{CS}$ Rising to D <sub>OUT</sub> Tri-State		25	50	ns
t <sub>en</sub>	DCLOCK Falling to D <sub>OUT</sub> Enabled		50	100	ns
t <sub>f</sub>	D <sub>OUT</sub> Fall Time		70	100	ns
t <sub>r</sub>	D <sub>OUT</sub> Rise Time		60	100	ns

TABLE I. Timing Specifications –40°C to +85°C.

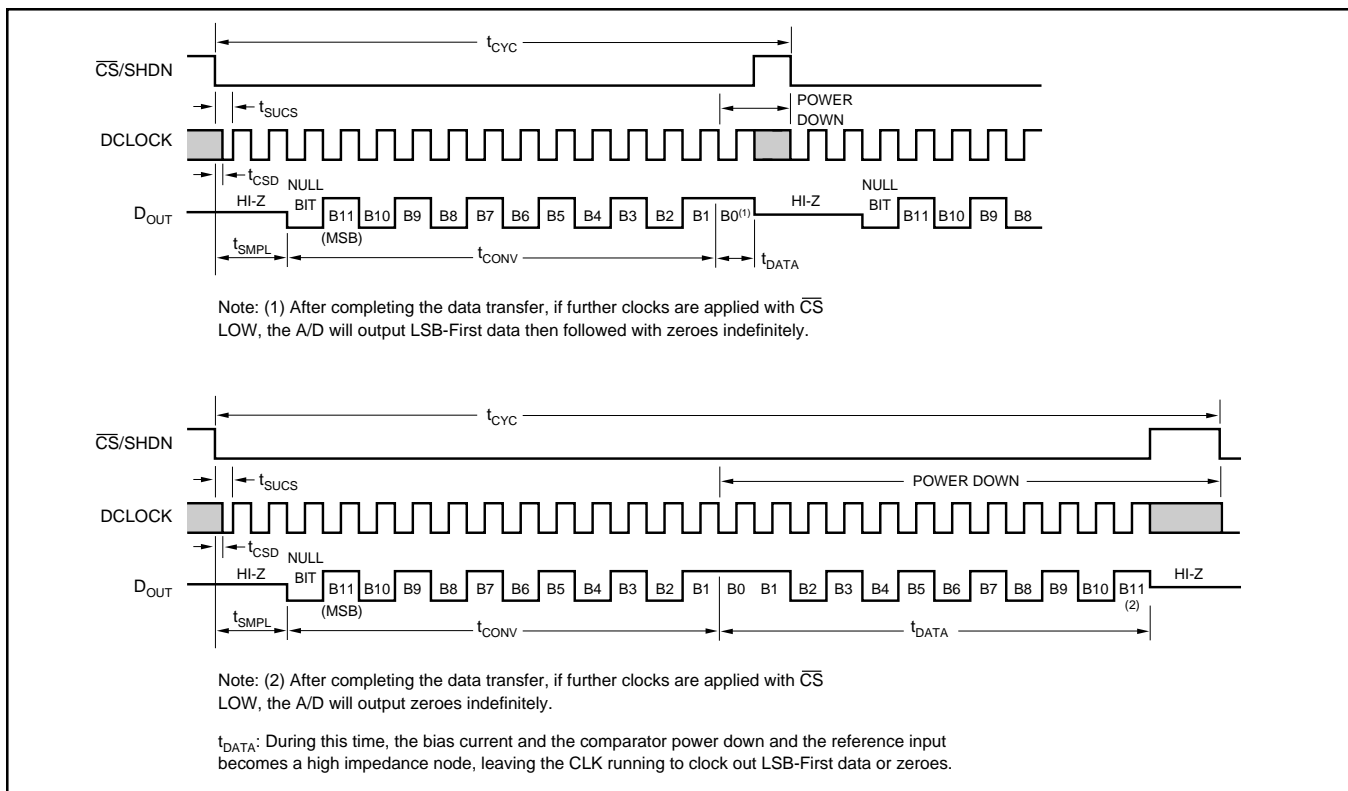

FIGURE 4. ADS7817 Basic Timing Diagrams.

A falling  $\overline{CS}$  signal initiates the conversion and data transfer. The first 1.5 to 2.0 clock periods of the conversion cycle are used to sample the input signal. After the second falling DCLOCK edge,  $D_{OUT}$  is enabled and will output a LOW value for one clock period. For the next 12 DCLOCK periods,  $D_{OUT}$  will output the conversion result, most significant bit first. After the least significant bit (B0) has been output, subsequent clocks will repeat the output data but in a least significant bit first format.

After the most significant bit (B11) has been repeated,  $D_{OUT}$  will tri-state. Subsequent clocks will have no effect on the converter. A new conversion is initiated only when  $\overline{CS}$  has been taken HIGH and returned LOW.

## DATA FORMAT

The output data from the ADS7817 is in Binary Two's Complement format as shown in Table II. This table represents the ideal output code for the given input voltage and does not include the effects of offset, gain error, or noise.

DESCRIPTION	ANALOG VALUE	DIGITAL OUTPUT: BINARY TWO'S COMPLEMENT	
		BINARY CODE	HEX CODE
Full Scale Input Span	$2 \cdot V_{REF}$		
Least Significant Bit (LSB)	$2 \cdot V_{REF}/4096$		
+Full Scale	$V_{REF} - 1 \text{ LSB}$	0111 1111 1111	7FF
Midscale	0V	0000 0000 0000	000
Midscale - 1 LSB	$0V - 1 \text{ LSB}$	1111 1111 1111	FFF
-Full Scale	$-V_{REF}$	1000 0000 0000	800

TABLE II. Ideal Input Voltages and Output Codes.

## POWER DISSIPATION

The architecture of the converter, the semiconductor fabrication process, and a careful design allow the ADS7817 to convert at up to a 200kHz rate while requiring very little power. Still, for the absolute lowest power dissipation, there are several things to keep in mind.

The power dissipation of the ADS7817 scales directly with conversion rate. The first step to achieving the lowest power dissipation is to find the lowest conversion rate that will satisfy the requirements of the system.

In addition, the ADS7817 is in power down mode under two conditions: when the conversion is complete and whenever  $\overline{CS}$  is HIGH (see Figure 1). Ideally, each conversion should occur as quickly as possible, preferably, at a 3.2MHz clock rate. This way, the converter spends the longest possible time in the power down mode. This is very important as the converter not only uses power on each DCLOCK transition (as is typical for digital CMOS components) but also uses some current for the analog circuitry, such as the comparator. The analog section dissipates power continuously, until the power down mode is entered.

Figure 6 shows the current consumption of the ADS7817 versus sample rate. For this graph, the converter is clocked at 3.2MHz regardless of the sample rate— $\overline{CS}$  is HIGH for the remaining sample period. Figure 7 also shows current consumption versus sample rate. However, in this case, the DCLOCK period is 1/16th of the sample period— $\overline{CS}$  is HIGH for one DCLOCK cycle out of every 16.

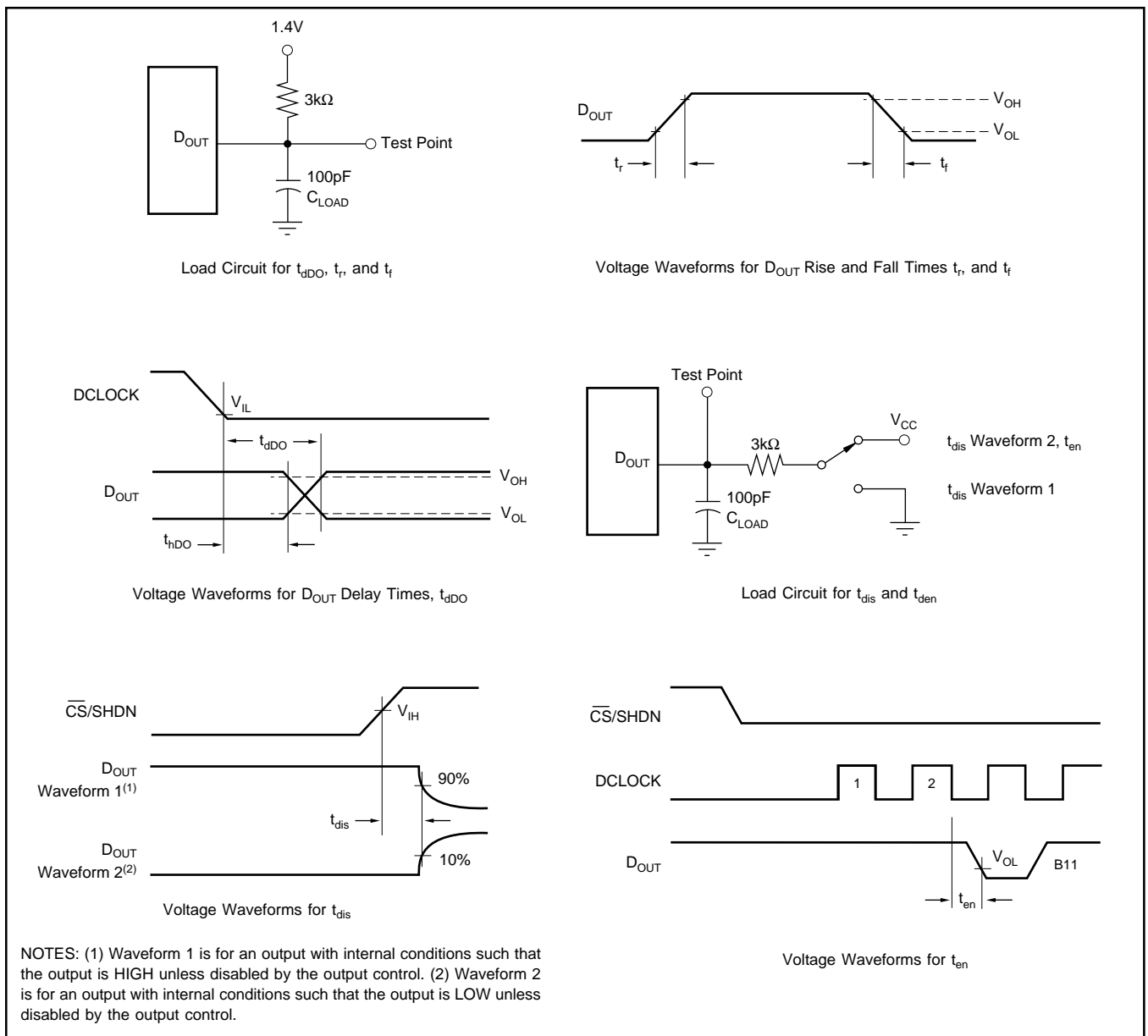

FIGURE 5. Timing Diagrams and Test Circuits for the Parameters in Table I.

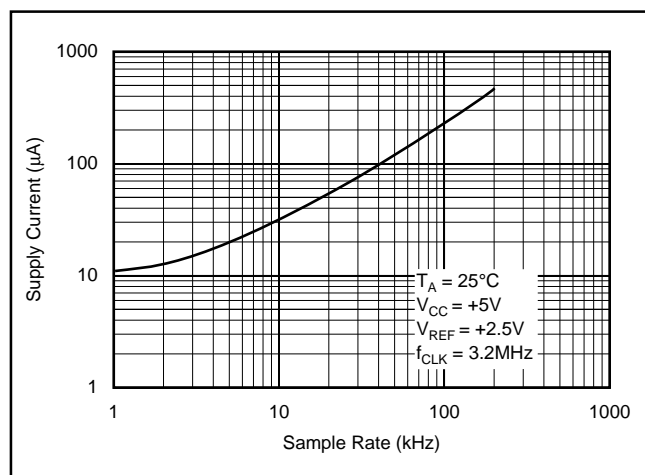

FIGURE 6. Maintaining  $f_{CLK}$  at the Highest Possible Rate Allows Supply Current to Drop Directly with Sample Rate.

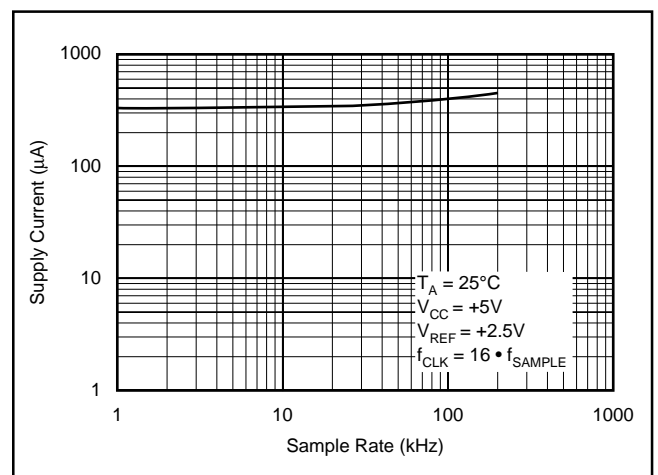

FIGURE 7. Scaling  $f_{CLK}$  Reduces Supply Current Only Slightly with Sample Rate.

There is an important distinction between the power down mode that is entered after a conversion is complete and the full power down mode which is enabled when  $\overline{CS}$  is HIGH. While both power down the analog section, the digital section is powered down only when  $\overline{CS}$  is HIGH. Thus, if  $\overline{CS}$  is left LOW at the end of a conversion and the converter is continually clocked, the power consumption will not be as low as when  $\overline{CS}$  is HIGH. See Figure 8 for more information.

By lowering the reference voltage, the ADS7817 requires less current to completely charge its internal capacitors on both the analog input and the reference input. This reduction in power dissipation should be weighed carefully against the resulting increase in noise, offset, and gain error as outlined in the Reference section.

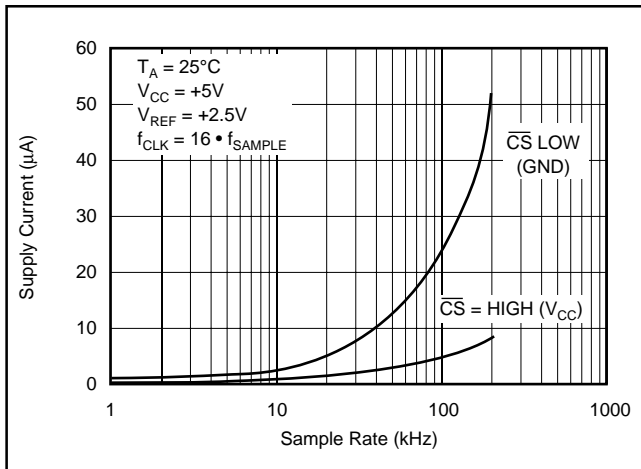

FIGURE 8. Shutdown Current is Considerably Lower with  $\overline{CS}$  HIGH than when  $\overline{CS}$  is LOW.

## SHORT CYCLING

Another way of saving power is to utilize the  $\overline{CS}$  signal to short cycle the conversion. Because the ADS7817 places the latest data bit on the  $D_{OUT}$  line as it is generated, the converter can easily be short cycled. This term means that the conversion can be terminated at any time. For example, if only 8-bits of the conversion result are needed, then the conversion can be terminated (by pulling  $\overline{CS}$  HIGH) after the 8th bit has been clocked out.

This technique can be used to lower the power dissipation in those applications where an analog signal is being monitored until some condition becomes true. For example, if the signal is outside a predetermined range, the full 12-bit conversion result may not be needed. If so, the conversion can be terminated after the first n-bits, where n might be as low as 3 or 4. This results in lower power dissipation in both the converter and the rest of the system, as they spend more time in the power down mode.

## LAYOUT

For optimum performance, care should be taken with the physical layout of the ADS7817 circuitry. This is particularly true if the reference voltage is low and/or the conversion rate is high. At 200kHz conversion rate, the ADS7817 makes a bit decision every 312ns. That is, for each subsequent bit decision, the digital output must be updated with the results of the last bit decision, the capacitor array appropriately switched and charged, and the input to the comparator settled to a 12-bit level all within one clock cycle.

The basic SAR architecture is sensitive to spikes on the power supply, reference, and ground connections that occur just prior to latching the comparator output. Thus, during any single conversion for an n-bit SAR converter, there are n “windows” in which large external transient voltages can easily affect the conversion result. Such spikes might originate from switching power supplies, digital logic, and high power devices, to name a few. This particular source of error can be very difficult to track down if the glitch is almost synchronous to the converter’s DCLOCK signal—as the phase difference between the two changes with time and temperature, causing sporadic misoperation.

With this in mind, power to the ADS7817 should be clean and well bypassed. A 0.1µF ceramic bypass capacitor should be placed as close to the ADS7817 package as possible. In addition, a 1 to 10µF capacitor and a 10Ω series resistor may be used to lowpass filter a noisy supply.

The reference should be similarly bypassed with a 0.1µF capacitor. Again, a series resistor and large capacitor can be used to lowpass filter the reference voltage. If the reference voltage originates from an op amp, be careful that the op-amp can drive the bypass capacitor without oscillation (the series resistor can help in this case). Keep in mind that while the ADS7817 draws very little current from the reference on average, there are higher instantaneous current demands placed on the external reference circuitry.

Also, keep in mind that the ADS7817 offers no inherent rejection of noise or voltage variation in regards to the reference input. This is of particular concern when the reference voltage is derived from the power supply. Any noise and ripple from the supply that is not rejected by the external reference circuitry will appear directly in the digital results. While high frequency noise can be filtered out as described in the previous paragraph, voltage variation due to line frequency (50Hz or 60Hz) can be difficult to remove.

The GND pin on the ADS7817 should be placed on a clean ground point. In many cases, this will be the “analog” ground. Avoid connecting the GND pin too close to the grounding point for a microprocessor, microcontroller, or digital signal processor. If needed, run a ground trace directly from the converter to the power supply connection point. The ideal layout will include an analog ground plane for the converter and associated analog circuitry.

# APPLICATION CIRCUITS

Figures 9, 10 and 11 show some typical applications circuits for the ADS7817. Figure 9 shows a low cost, low power circuit for basic data acquisition. Total power dissipation in the ADS7817 and reference circuitry is under 5mW over temperature, power supply variations, and at a 200kHz sample rate.

Figure 10 is a motor control application using three ISO130s to isolate the motor from the sensing system (three ADS7817s and a DSP56004). The ISO130 provides 10kV/ $\mu$ s (minimum) isolation-mode rejection, 85kHz large signal bandwidth, and a fixed gain of 8. The ADS7817's reference voltage is 1.2V and is derived from a REF1004-1.2. This gives the converter a full-scale input range of  $\pm$ 1.2V. Because of the gain of 8 in the ISO130, the current sense resistor should give a worst-case output voltage of less than  $\pm$ 150mV.

Figure 11 is a similar application that isolates the digital outputs of the three ADS7817s instead of the analog signal from the motor. Here, the reference voltage for the ADS7817 is 150mV, and the analog input of each ADS7817 is connected directly to the current sense resistor. By removing the ISO130 from the signal path, a greater signal-to-noise ratio is achieved in the sensing system. However, nine optical isolators are needed to isolate the A/D converters.

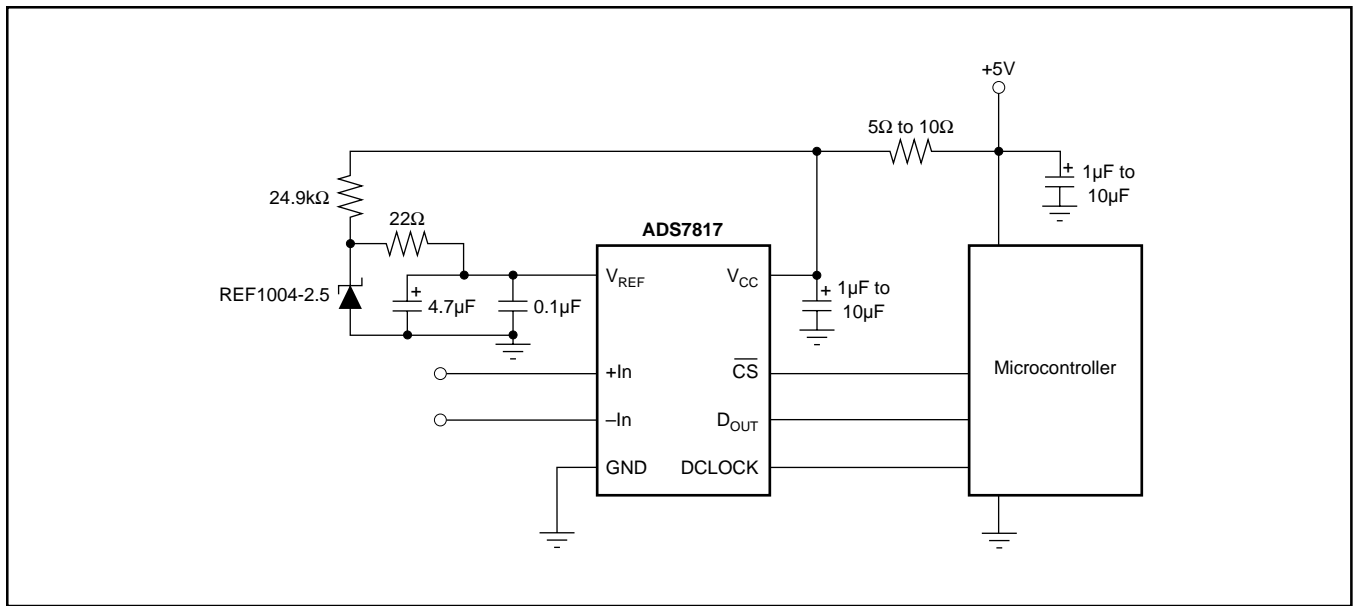

FIGURE 9. Low Cost, Low Power Data Acquisition System.

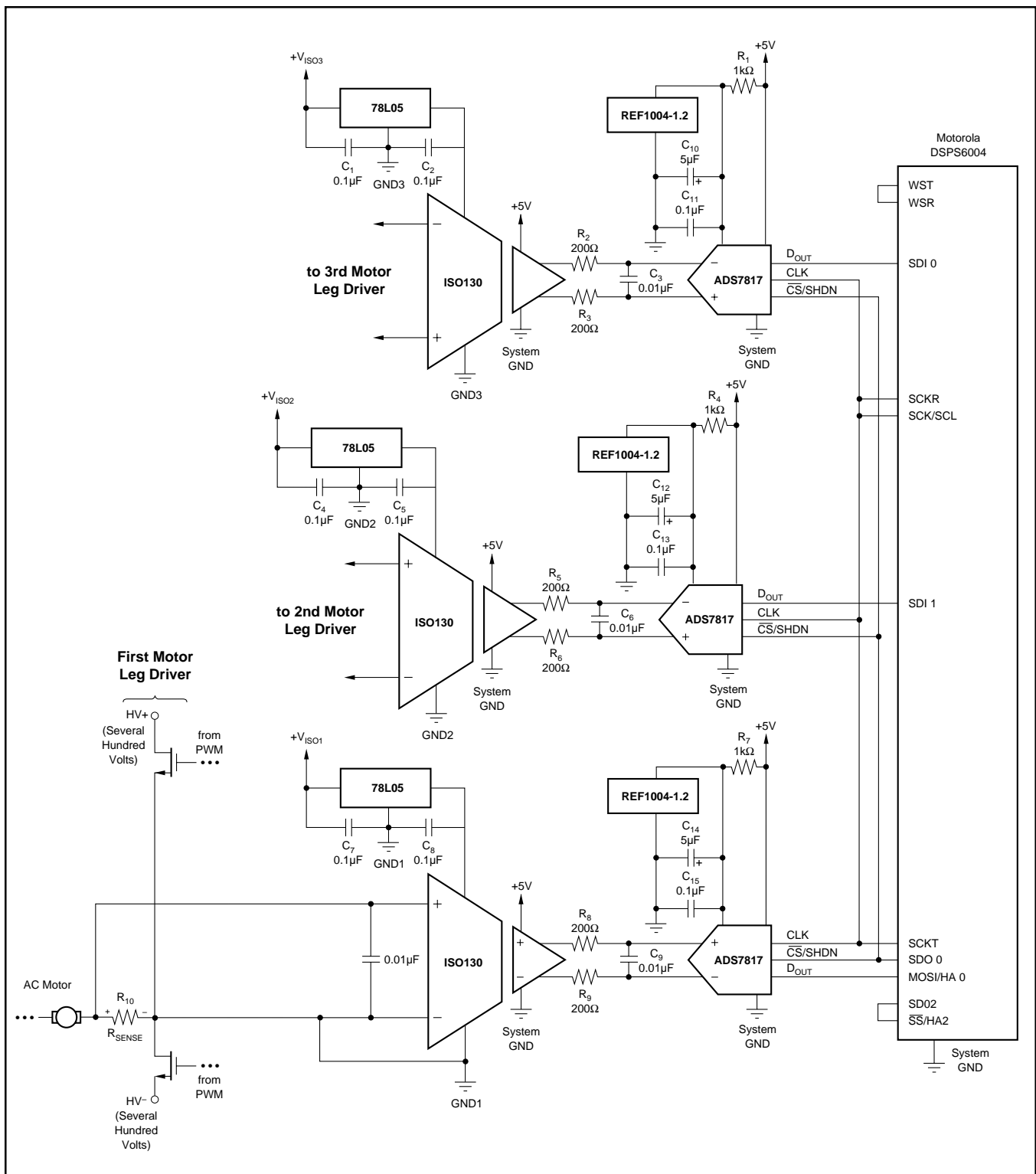

FIGURE 10. Motor Control Using the ISO130, ADS7817, and DSPS6004.

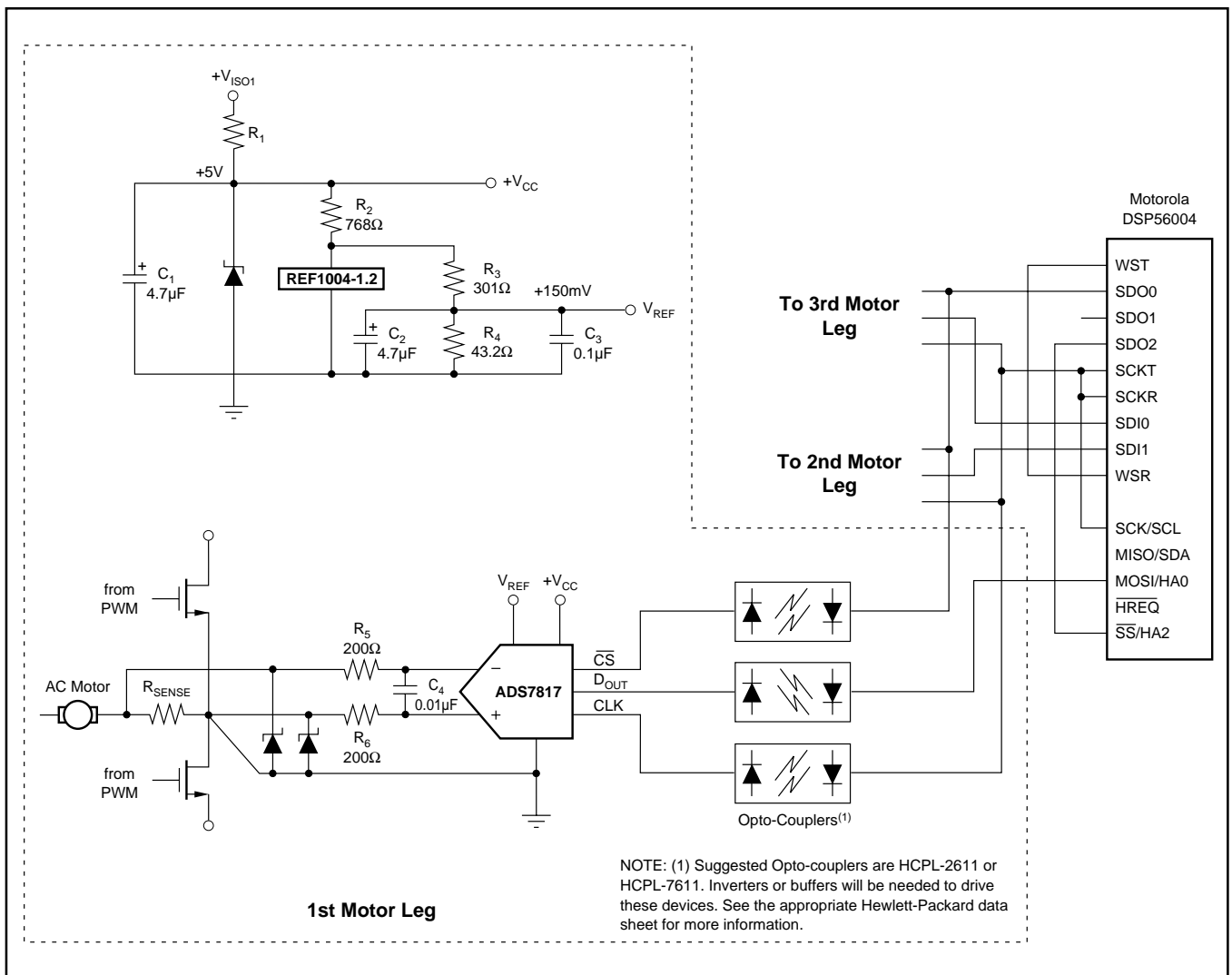

FIGURE 11. Motor Control Using an Isolated ADS7817.

**PACKAGING INFORMATION**

Orderable Device	Status <sup>(1)</sup>	Package Type	Package Drawing	Pins	Package Qty	Eco Plan <sup>(2)</sup>	Lead/Ball Finish	MSL Peak Temp <sup>(3)</sup>
ADS7817E/250	ACTIVE	MSOP	DGK	8	250	Green (RoHS & no Sb/Br)	CU NIPDAU	Level-1-260C-UNLIM
ADS7817E/250G4	ACTIVE	MSOP	DGK	8	250	Green (RoHS & no Sb/Br)	CU NIPDAU	Level-1-260C-UNLIM
ADS7817E/2K5	ACTIVE	MSOP	DGK	8	2500	Green (RoHS & no Sb/Br)	CU NIPDAU	Level-1-260C-UNLIM
ADS7817E/2K5G4	ACTIVE	MSOP	DGK	8	2500	Green (RoHS & no Sb/Br)	CU NIPDAU	Level-1-260C-UNLIM
ADS7817EB/250	ACTIVE	MSOP	DGK	8	250	Green (RoHS & no Sb/Br)	CU NIPDAU	Level-1-260C-UNLIM
ADS7817EB/250G4	ACTIVE	MSOP	DGK	8	250	Green (RoHS & no Sb/Br)	CU NIPDAU	Level-1-260C-UNLIM
ADS7817EB/2K5	ACTIVE	MSOP	DGK	8	2500	Green (RoHS & no Sb/Br)	CU NIPDAU	Level-1-260C-UNLIM
ADS7817EB/2K5G4	ACTIVE	MSOP	DGK	8	2500	Green (RoHS & no Sb/Br)	CU NIPDAU	Level-1-260C-UNLIM
ADS7817EC/250	ACTIVE	MSOP	DGK	8	250	Green (RoHS & no Sb/Br)	CU NIPDAU	Level-1-260C-UNLIM
ADS7817EC/250G4	ACTIVE	MSOP	DGK	8	250	Green (RoHS & no Sb/Br)	CU NIPDAU	Level-1-260C-UNLIM
ADS7817EC/2K5	ACTIVE	MSOP	DGK	8	2500	Green (RoHS & no Sb/Br)	CU NIPDAU	Level-1-260C-UNLIM
ADS7817EC/2K5G4	ACTIVE	MSOP	DGK	8	2500	Green (RoHS & no Sb/Br)	CU NIPDAU	Level-1-260C-UNLIM
ADS7817P	OBSOLETE	PDIP	P	8		TBD	Call TI	Call TI
ADS7817PB	OBSOLETE	PDIP	P	8		TBD	Call TI	Call TI
ADS7817PC	OBSOLETE	PDIP	P	8		TBD	Call TI	Call TI
ADS7817U	ACTIVE	SOIC	D	8	100	Green (RoHS & no Sb/Br)	CU NIPDAU	Level-2-260C-1 YEAR
ADS7817U/2K5	ACTIVE	SOIC	D	8	2500	Green (RoHS & no Sb/Br)	CU NIPDAU	Level-2-260C-1 YEAR
ADS7817U/2K5G4	ACTIVE	SOIC	D	8	2500	Green (RoHS & no Sb/Br)	CU NIPDAU	Level-2-260C-1 YEAR
ADS7817UB	ACTIVE	SOIC	D	8	100	Green (RoHS & no Sb/Br)	CU NIPDAU	Level-2-260C-1 YEAR
ADS7817UB/2K5	ACTIVE	SOIC	D	8	2500	Green (RoHS & no Sb/Br)	CU NIPDAU	Level-2-260C-1 YEAR
ADS7817UB/2K5G4	ACTIVE	SOIC	D	8	2500	Green (RoHS & no Sb/Br)	CU NIPDAU	Level-2-260C-1 YEAR
ADS7817UBG4	ACTIVE	SOIC	D	8	100	Green (RoHS & no Sb/Br)	CU NIPDAU	Level-2-260C-1 YEAR
ADS7817UC	ACTIVE	SOIC	D	8	100	Green (RoHS & no Sb/Br)	CU NIPDAU	Level-2-260C-1 YEAR
ADS7817UC/2K5	ACTIVE	SOIC	D	8	2500	Green (RoHS & no Sb/Br)	CU NIPDAU	Level-2-260C-1 YEAR
ADS7817UC/2K5G4	ACTIVE	SOIC	D	8	2500	Green (RoHS & no Sb/Br)	CU NIPDAU	Level-2-260C-1 YEAR
ADS7817UCG4	ACTIVE	SOIC	D	8	100	Green (RoHS & no Sb/Br)	CU NIPDAU	Level-2-260C-1 YEAR

Orderable Device	Status <sup>(1)</sup>	Package Type	Package Drawing	Pins	Package Qty	Eco Plan <sup>(2)</sup>	Lead/Ball Finish	MSL Peak Temp <sup>(3)</sup>
ADS7817UG4	ACTIVE	SOIC	D	8	100	Green (RoHS & no Sb/Br)	CU NIPDAU	Level-2-260C-1 YEAR

<sup>(1)</sup> The marketing status values are defined as follows:

**ACTIVE:** Product device recommended for new designs.

**LIFEBUY:** TI has announced that the device will be discontinued, and a lifetime-buy period is in effect.

**NRND:** Not recommended for new designs. Device is in production to support existing customers, but TI does not recommend using this part in a new design.

**PREVIEW:** Device has been announced but is not in production. Samples may or may not be available.

**OBSOLETE:** TI has discontinued the production of the device.

<sup>(2)</sup> Eco Plan - The planned eco-friendly classification: Pb-Free (RoHS), Pb-Free (RoHS Exempt), or Green (RoHS & no Sb/Br) - please check <http://www.ti.com/productcontent> for the latest availability information and additional product content details.

**TBD:** The Pb-Free/Green conversion plan has not been defined.

**Pb-Free (RoHS):** TI's terms "Lead-Free" or "Pb-Free" mean semiconductor products that are compatible with the current RoHS requirements for all 6 substances, including the requirement that lead not exceed 0.1% by weight in homogeneous materials. Where designed to be soldered at high temperatures, TI Pb-Free products are suitable for use in specified lead-free processes.

**Pb-Free (RoHS Exempt):** This component has a RoHS exemption for either 1) lead-based flip-chip solder bumps used between the die and package, or 2) lead-based die adhesive used between the die and leadframe. The component is otherwise considered Pb-Free (RoHS compatible) as defined above.

**Green (RoHS & no Sb/Br):** TI defines "Green" to mean Pb-Free (RoHS compatible), and free of Bromine (Br) and Antimony (Sb) based flame retardants (Br or Sb do not exceed 0.1% by weight in homogeneous material)

<sup>(3)</sup> MSL, Peak Temp. -- The Moisture Sensitivity Level rating according to the JEDEC industry standard classifications, and peak solder temperature.

**Important Information and Disclaimer:** The information provided on this page represents TI's knowledge and belief as of the date that it is provided. TI bases its knowledge and belief on information provided by third parties, and makes no representation or warranty as to the accuracy of such information. Efforts are underway to better integrate information from third parties. TI has taken and continues to take reasonable steps to provide representative and accurate information but may not have conducted destructive testing or chemical analysis on incoming materials and chemicals. TI and TI suppliers consider certain information to be proprietary, and thus CAS numbers and other limited information may not be available for release.

In no event shall TI's liability arising out of such information exceed the total purchase price of the TI part(s) at issue in this document sold by TI to Customer on an annual basis.

## IMPORTANT NOTICE

Texas Instruments Incorporated and its subsidiaries (TI) reserve the right to make corrections, modifications, enhancements, improvements, and other changes to its products and services at any time and to discontinue any product or service without notice. Customers should obtain the latest relevant information before placing orders and should verify that such information is current and complete. All products are sold subject to TI's terms and conditions of sale supplied at the time of order acknowledgment.

TI warrants performance of its hardware products to the specifications applicable at the time of sale in accordance with TI's standard warranty. Testing and other quality control techniques are used to the extent TI deems necessary to support this warranty. Except where mandated by government requirements, testing of all parameters of each product is not necessarily performed.

TI assumes no liability for applications assistance or customer product design. Customers are responsible for their products and applications using TI components. To minimize the risks associated with customer products and applications, customers should provide adequate design and operating safeguards.

TI does not warrant or represent that any license, either express or implied, is granted under any TI patent right, copyright, mask work right, or other TI intellectual property right relating to any combination, machine, or process in which TI products or services are used. Information published by TI regarding third-party products or services does not constitute a license from TI to use such products or services or a warranty or endorsement thereof. Use of such information may require a license from a third party under the patents or other intellectual property of the third party, or a license from TI under the patents or other intellectual property of TI.

Reproduction of information in TI data books or data sheets is permissible only if reproduction is without alteration and is accompanied by all associated warranties, conditions, limitations, and notices. Reproduction of this information with alteration is an unfair and deceptive business practice. TI is not responsible or liable for such altered documentation.

Resale of TI products or services with statements different from or beyond the parameters stated by TI for that product or service voids all express and any implied warranties for the associated TI product or service and is an unfair and deceptive business practice. TI is not responsible or liable for any such statements.

Following are URLs where you can obtain information on other Texas Instruments products and application solutions:

<b>Products</b>		<b>Applications</b>	
Amplifiers	<a href="http://amplifier.ti.com">amplifier.ti.com</a>	Audio	<a href="http://www.ti.com/audio">www.ti.com/audio</a>
Data Converters	<a href="http://dataconverter.ti.com">dataconverter.ti.com</a>	Automotive	<a href="http://www.ti.com/automotive">www.ti.com/automotive</a>
DSP	<a href="http://dsp.ti.com">dsp.ti.com</a>	Broadband	<a href="http://www.ti.com/broadband">www.ti.com/broadband</a>
Interface	<a href="http://interface.ti.com">interface.ti.com</a>	Digital Control	<a href="http://www.ti.com/digitalcontrol">www.ti.com/digitalcontrol</a>
Logic	<a href="http://logic.ti.com">logic.ti.com</a>	Military	<a href="http://www.ti.com/military">www.ti.com/military</a>
Power Mgmt	<a href="http://power.ti.com">power.ti.com</a>	Optical Networking	<a href="http://www.ti.com/opticalnetwork">www.ti.com/opticalnetwork</a>
Microcontrollers	<a href="http://microcontroller.ti.com">microcontroller.ti.com</a>	Security	<a href="http://www.ti.com/security">www.ti.com/security</a>
Low Power Wireless	<a href="http://www.ti.com/lpw">www.ti.com/lpw</a>	Telephony	<a href="http://www.ti.com/telephony">www.ti.com/telephony</a>
		Video & Imaging	<a href="http://www.ti.com/video">www.ti.com/video</a>
		Wireless	<a href="http://www.ti.com/wireless">www.ti.com/wireless</a>

Mailing Address: Texas Instruments  
Post Office Box 655303 Dallas, Texas 75265