



IRF730

N-channel 400V - 0.75 Ω - 5.5A TO-220
Powermesh™II Power MOSFET

General features

| Type | V _{DSS} | R _{DS(on)} | I _D |
|--------|------------------|---------------------|----------------|
| IRF730 | 400V | <1 Ω | 5.5A |

- Exceptional dv/dt capability
- 100% avalanche tested
- Low gate charge

Description

The PowerMESH™II is the evolution of the first generation of MESH OVERLAY™. The layout refinements introduced greatly improve the Ron*area figure of merit while keeping the device at the leading edge for what concerns switching speed, gate charge and ruggedness.

Applications

- Switching application

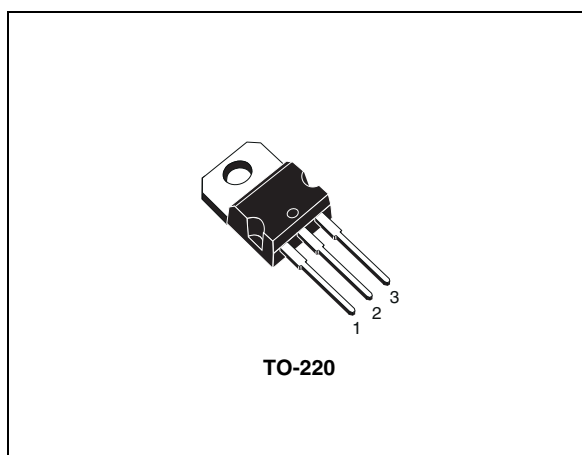

Internal schematic diagram

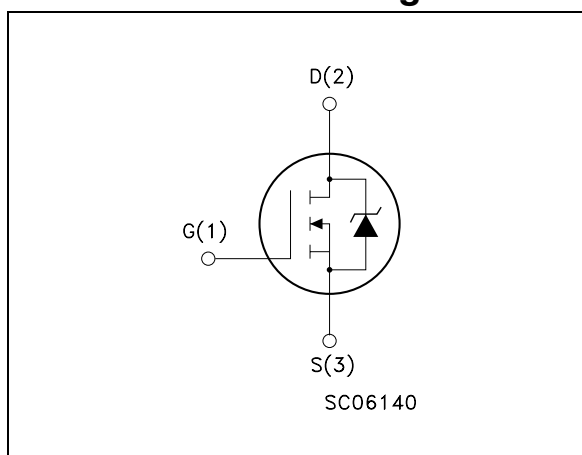

Order codes

| Part number | Marking | Package | Packaging |
|-------------|---------|---------|-----------|
| IRF730 | IRF730 | TO-220 | Tube |

Contents

| | | |
|----------|---|-----------|
| 1 | Electrical ratings | 3 |
| 2 | Electrical characteristics | 4 |
| | 2.1 Electrical characteristics (curves) | 6 |
| 3 | Test circuit | 8 |
| 4 | Package mechanical data | 9 |
| 5 | Revision history | 11 |

1 Electrical ratings

Table 1. Absolute maximum ratings

| Symbol | Parameter | Value | Unit |
|----------------|---|------------|---------------------|
| V_{DS} | Drain-source voltage ($V_{GS} = 0$) | 400 | V |
| V_{DGR} | Drain-gate voltage ($R_{GS} = 20\text{ k}\Omega$) | 400 | V |
| V_{GS} | Gate- source voltage | ± 20 | V |
| I_D | Drain current (continuous) at $T_C = 25^\circ\text{C}$ | 5.5 | A |
| I_D | Drain current (continuous) at $T_C = 100^\circ\text{C}$ | 3.5 | A |
| $I_{DM}^{(1)}$ | Drain current (pulsed) | 22 | A |
| P_{TOT} | Total dissipation at $T_C = 25^\circ\text{C}$ | 100 | W |
| | Derating factor | 0.8 | W/ $^\circ\text{C}$ |
| $dv/dt^{(2)}$ | Peak diode recovery voltage slope | 3 | V/ns |
| T_{stg} | Storage temperature | -65 to 150 | $^\circ\text{C}$ |
| T_j | Max. operating junction temperature | 150 | $^\circ\text{C}$ |

1. Pulse width limited by safe operating area

2. $I_{SD} \leq 5.5\text{A}$, $di/dt \leq 90\text{A}/\mu\text{s}$, $V_{DD} \leq V_{(BR)DSS}$, $T_j \leq T_{jmax}$.

Table 2. Thermal data

| | | | |
|-----------|--|------|---------------------------|
| Rthj-case | Thermal resistance junction-case max | 1.25 | $^\circ\text{C}/\text{W}$ |
| Rthj-amb | Thermal resistance junction-ambient max | 62.5 | $^\circ\text{C}/\text{W}$ |
| Rthc-sink | Thermal resistance case-sink typ | 0.5 | $^\circ\text{C}/\text{W}$ |
| T_l | Maximum lead temperature for soldering purpose | 300 | $^\circ\text{C}$ |

Table 3. Avalanche characteristics

| Symbol | Parameter | Max Value | Unit |
|----------|---|-----------|------|
| I_{AR} | Avalanche current, repetitive or not-repetitive (pulse width limited by T_j max) | 5.5 | A |
| E_{AS} | Single pulse avalanche energy (starting $T_j = 25^\circ\text{C}$, $I_D = I_{AR}$, $V_{DD} = 50\text{V}$) | 300 | mJ |

2 Electrical characteristics

($T_{CASE}=25^{\circ}\text{C}$ unless otherwise specified)

Table 4. On/off

| Symbol | Parameter | Test conditions | Min. | Typ. | Max. | Unit |
|---------------|--|---|------|------|-----------|--------------------------------|
| $V_{(BR)DSS}$ | Drain-source breakdown voltage | $I_D = 250 \mu\text{A}$, $V_{GS} = 0$ | 400 | | | V |
| I_{DSS} | Zero gate voltage drain current ($V_{GS} = 0$) | $V_{DS} = \text{max rating}$ $V_{DS} = \text{max rating}$, $T_C = 125^{\circ}\text{C}$ | | | 1 50 | μA μA |
| I_{GSS} | Gate-body leakage current ($V_{DS} = 0$) | $V_{GS} = \pm 20\text{V}$ | | | ± 100 | nA |
| $V_{GS(th)}$ | Gate threshold voltage | $V_{DS} = V_{GS}$, $I_D = 250\mu\text{A}$ | 2 | 3 | 4 | V |
| $R_{DS(on)}$ | Static drain-source on resistance | $V_{GS} = 10\text{V}$, $I_D = 3 \text{A}$ | | 0.75 | 1 | Ω |

Table 5. Dynamic

| Symbol | Parameter | Test conditions | Min. | Typ. | Max. | Unit |
|---|---|---|------|-----------------|------|----------------------|
| $g_{fs}^{(1)}$ | Forward transconductance | $V_{DS} > I_{D(on)} \times R_{DS(on)max}$, $I_D = 3 \text{A}$ | 2.9 | | | S |
| C_{iss} C_{oss} C_{rss} | Input capacitance Output capacitance Reverse transfer capacitance | $V_{DS} = 25\text{V}$, $f = 1 \text{MHz}$, $V_{GS} = 0$ | | 530 90 15 | | pF pF pF |
| $t_{d(on)}$ t_r $t_{d(off)}$ t_f | Turn-on delay time Rise time Off-voltage rise time Fall time | $V_{DD} = 200\text{V}$, $I_D = 3\text{A}$ $R_G = 4.7\Omega$, $V_{GS} = 10\text{V}$ | | 11 15 | | ns ns ns ns |
| Q_g Q_{gs} Q_{gd} | Total gate charge Gate-source charge Gate-drain charge | $V_{DD} = 320\text{V}$, $I_D = 5.5\text{A}$, $V_{GS} = 10\text{V}$ | | 18 4 8.5 | 24 | nC nC nC |

1. Pulsed: Pulse duration = 300 μs , duty cycle 1.5 %.

Table 6. Source drain diode

| Symbol | Parameter | Test conditions | Min. | Typ. | Max. | Unit |
|-----------------------------------|--|--|------|------------------|---------|--------------------|
| I_{SD} $I_{SDM}^{(1)}$ | Source-drain current Source-drain current (pulsed) | | | | 6 24 | A A |
| $V_{SD}^{(2)}$ | Forward on voltage | $I_{SD} = 5.5A, V_{GS} = 0$ | | | 1.6 | V |
| t_{rr} Q_{rr} I_{RRM} | Reverse recovery time Reverse recovery charge Reverse recovery current | $I_{SD} = 7A, di/dt = 100A/\mu s,$ $V_{DD} = 100V, T_j = 150^\circ C$ | | 280 1.4 10 | | ns μC A |

1. Pulse width limited by safe operating area.
2. Pulsed: Pulse duration = 300 μs , duty cycle 1.5 %

2.1 Electrical characteristics (curves)

Figure 1. Safe operating area

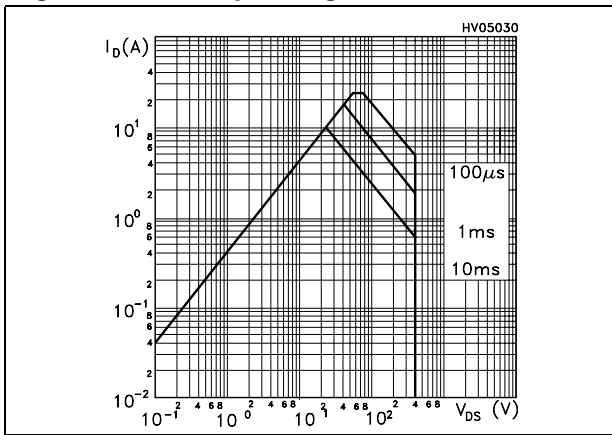

Figure 2. Thermal impedance

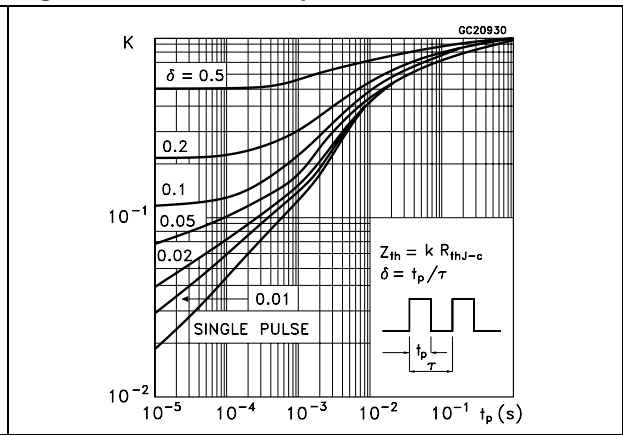

Figure 3. Output characteristics

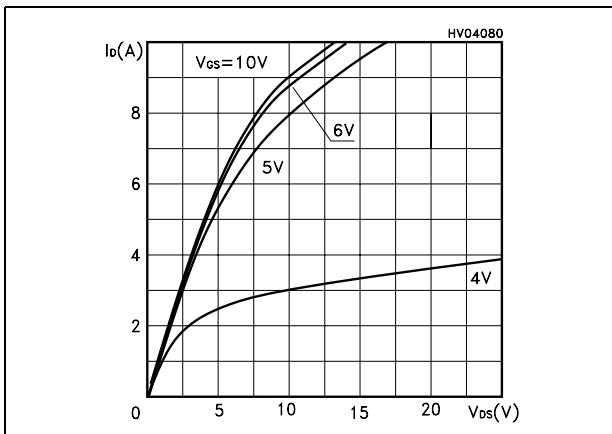

Figure 4. Transfer characteristics

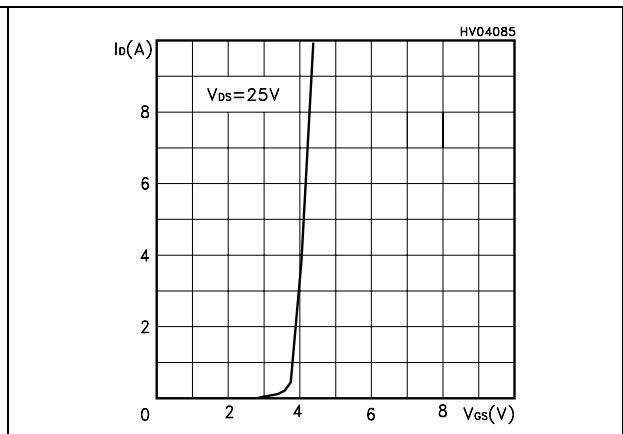

Figure 5. Transconductance

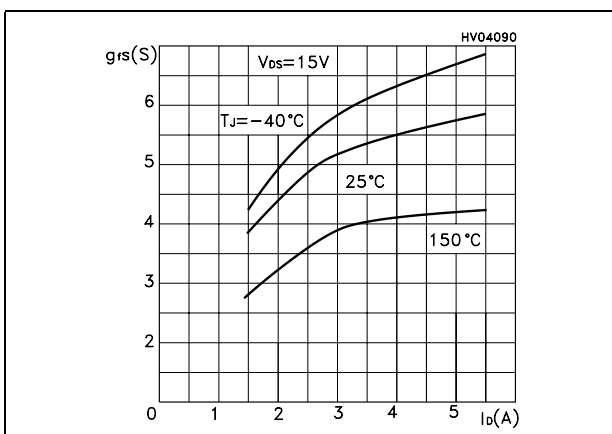

Figure 6. Static drain-source on resistance

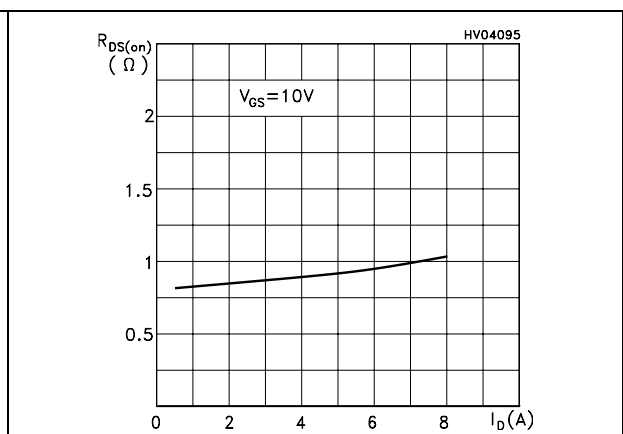

Figure 7. Gate charge vs gate-source voltage Figure 8. Capacitance variations

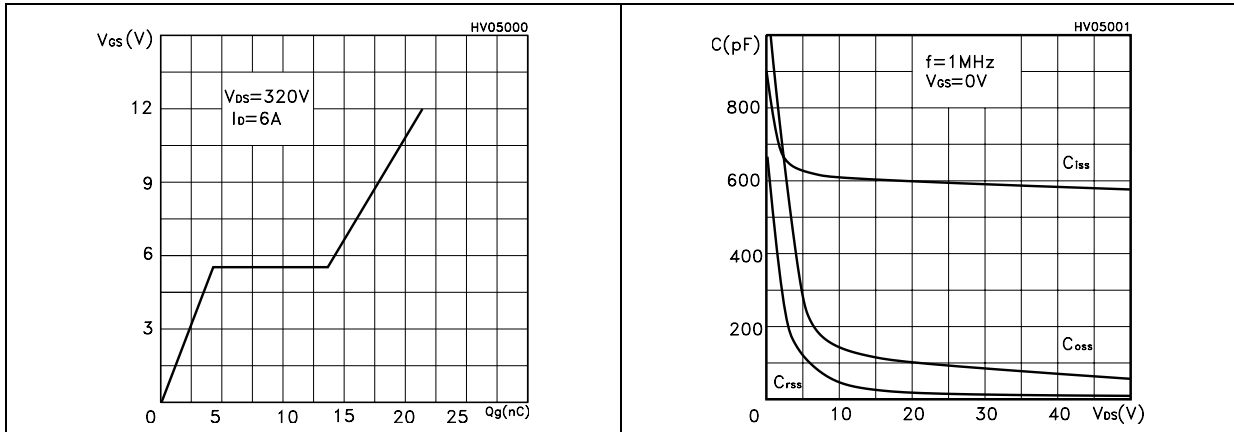

Figure 9. Normalized gate threshold voltage vs temperature Figure 10. Normalized on resistance vs temperature

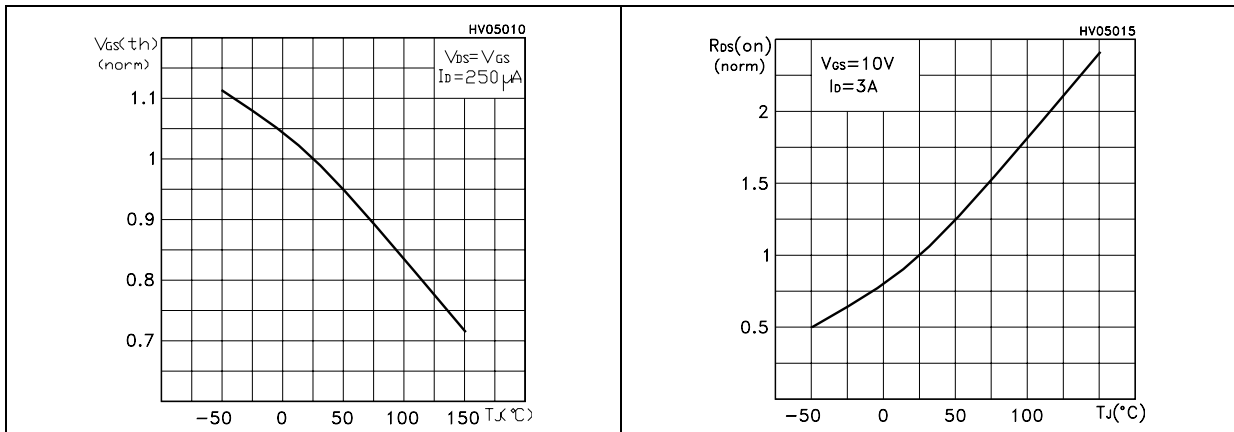
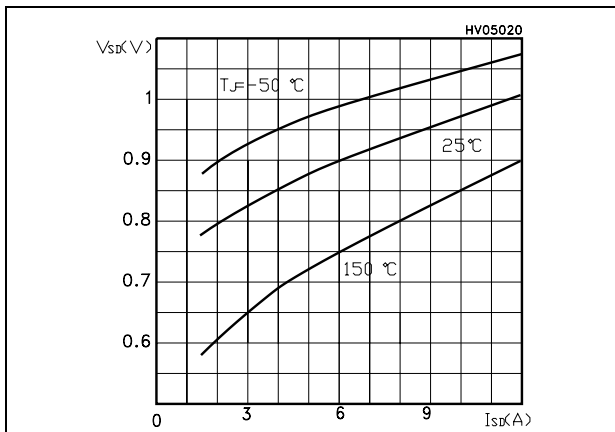

Figure 11. Source-drain diode forward characteristics



3 Test circuit

Figure 12. Unclamped Inductive load test circuit

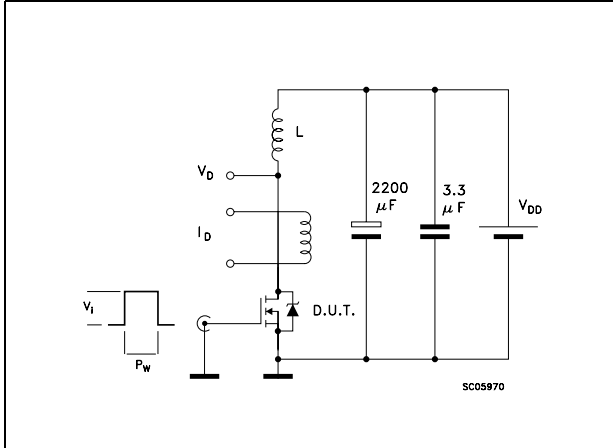

Figure 13. Unclamped inductive waveform

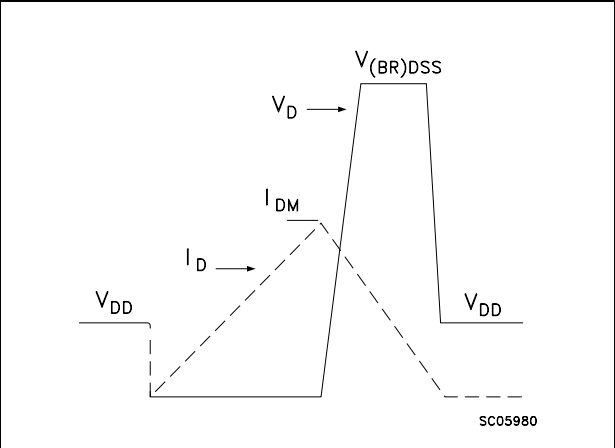

Figure 14. Switching times test circuit for resistive load

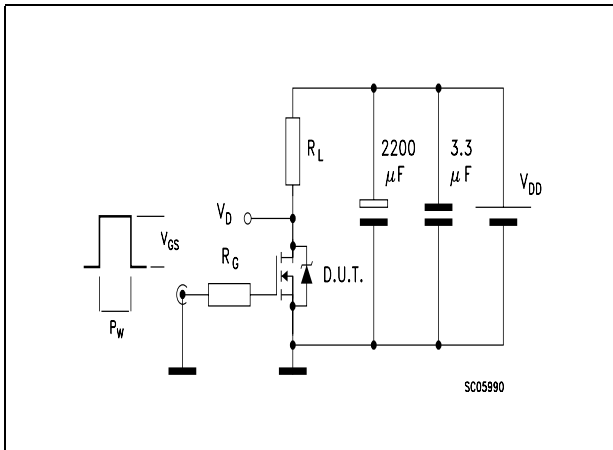

Figure 15. Gate charge test circuit

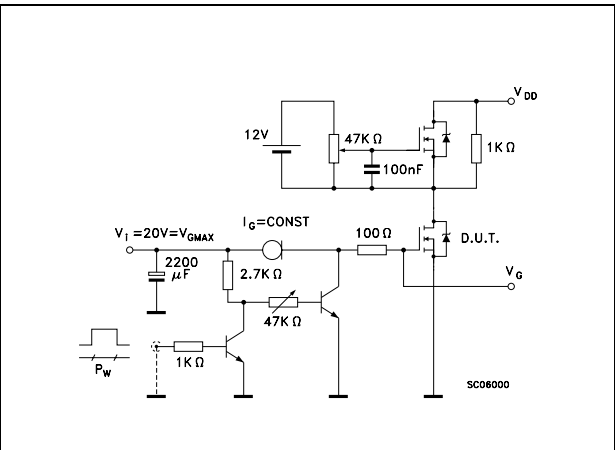
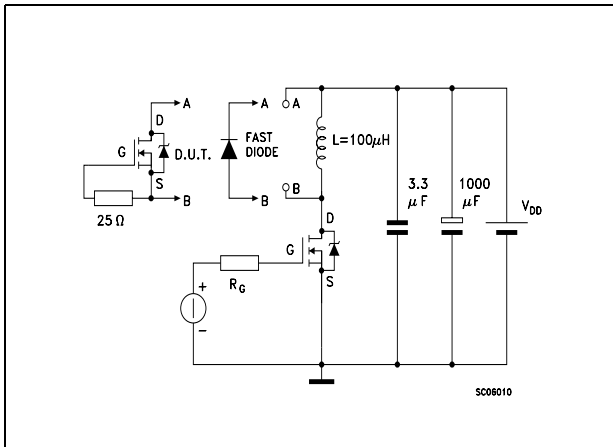

Figure 16. Test circuit for inductive load switching and diode recovery times



4 Package mechanical data

In order to meet environmental requirements, ST offers these devices in ECOPACK® packages. These packages have a Lead-free second level interconnect . The category of second level interconnect is marked on the package and on the inner box label, in compliance with JEDEC Standard JESD97. The maximum ratings related to soldering conditions are also marked on the inner box label. ECOPACK is an ST trademark. ECOPACK specifications are available at: www.st.com

TO-220 MECHANICAL DATA

| DIM. | mm. | | | inch | | |
|------|-------|-------|-------|-------|-------|-------|
| | MIN. | TYP. | MAX. | MIN. | TYP. | MAX. |
| A | 4.40 | | 4.60 | 0.173 | | 0.181 |
| b | 0.61 | | 0.88 | 0.024 | | 0.034 |
| b1 | 1.15 | | 1.70 | 0.045 | | 0.066 |
| c | 0.49 | | 0.70 | 0.019 | | 0.027 |
| D | 15.25 | | 15.75 | 0.60 | | 0.620 |
| E | 10 | | 10.40 | 0.393 | | 0.409 |
| e | 2.40 | | 2.70 | 0.094 | | 0.106 |
| e1 | 4.95 | | 5.15 | 0.194 | | 0.202 |
| F | 1.23 | | 1.32 | 0.048 | | 0.052 |
| H1 | 6.20 | | 6.60 | 0.244 | | 0.256 |
| J1 | 2.40 | | 2.72 | 0.094 | | 0.107 |
| L | 13 | | 14 | 0.511 | | 0.551 |
| L1 | 3.50 | | 3.93 | 0.137 | | 0.154 |
| L20 | | 16.40 | | | 0.645 | |
| L30 | | 28.90 | | | 1.137 | |
| øP | 3.75 | | 3.85 | 0.147 | | 0.151 |
| Q | 2.65 | | 2.95 | 0.104 | | 0.116 |

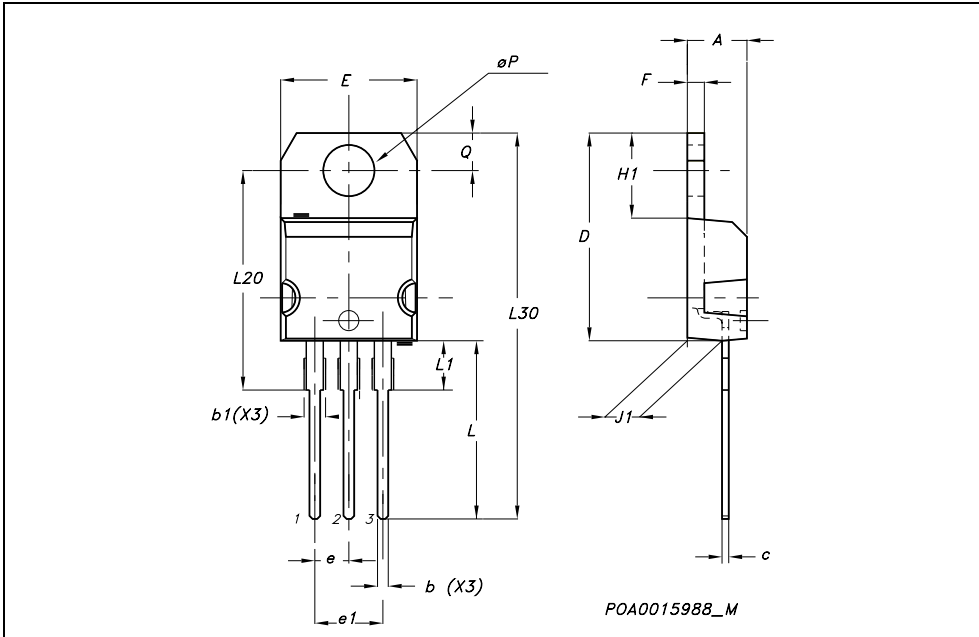

5 Revision history

Table 7. Revision history

| Date | Revision | Changes |
|-------------|-----------------|---------------------------------|
| 21-Jun-2004 | 3 | Preliminary version |
| 29-Jun-2006 | 4 | New template, no content change |

Please Read Carefully:

Information in this document is provided solely in connection with ST products. STMicroelectronics NV and its subsidiaries ("ST") reserve the right to make changes, corrections, modifications or improvements, to this document, and the products and services described herein at any time, without notice.

All ST products are sold pursuant to ST's terms and conditions of sale.

Purchasers are solely responsible for the choice, selection and use of the ST products and services described herein, and ST assumes no liability whatsoever relating to the choice, selection or use of the ST products and services described herein.

No license, express or implied, by estoppel or otherwise, to any intellectual property rights is granted under this document. If any part of this document refers to any third party products or services it shall not be deemed a license grant by ST for the use of such third party products or services, or any intellectual property contained therein or considered as a warranty covering the use in any manner whatsoever of such third party products or services or any intellectual property contained therein.

UNLESS OTHERWISE SET FORTH IN ST'S TERMS AND CONDITIONS OF SALE ST DISCLAIMS ANY EXPRESS OR IMPLIED WARRANTY WITH RESPECT TO THE USE AND/OR SALE OF ST PRODUCTS INCLUDING WITHOUT LIMITATION IMPLIED WARRANTIES OF MERCHANTABILITY, FITNESS FOR A PARTICULAR PURPOSE (AND THEIR EQUIVALENTS UNDER THE LAWS OF ANY JURISDICTION), OR INFRINGEMENT OF ANY PATENT, COPYRIGHT OR OTHER INTELLECTUAL PROPERTY RIGHT.

UNLESS EXPRESSLY APPROVED IN WRITING BY AN AUTHORIZED REPRESENTATIVE OF ST, ST PRODUCTS ARE NOT DESIGNED, AUTHORIZED OR WARRANTED FOR USE IN MILITARY, AIR CRAFT, SPACE, LIFE SAVING, OR LIFE SUSTAINING APPLICATIONS, NOR IN PRODUCTS OR SYSTEMS, WHERE FAILURE OR MALFUNCTION MAY RESULT IN PERSONAL INJURY, DEATH, OR SEVERE PROPERTY OR ENVIRONMENTAL DAMAGE.

Resale of ST products with provisions different from the statements and/or technical features set forth in this document shall immediately void any warranty granted by ST for the ST product or service described herein and shall not create or extend in any manner whatsoever, any liability of ST.

ST and the ST logo are trademarks or registered trademarks of ST in various countries.

Information in this document supersedes and replaces all information previously supplied.

The ST logo is a registered trademark of STMicroelectronics. All other names are the property of their respective owners.

© 2006 STMicroelectronics - All rights reserved

STMicroelectronics group of companies

Australia - Belgium - Brazil - Canada - China - Czech Republic - Finland - France - Germany - Hong Kong - India - Israel - Italy - Japan - Malaysia - Malta - Morocco - Singapore - Spain - Sweden - Switzerland - United Kingdom - United States of America

www.st.com