

DO NOT SCALE FROM THIS PRINT

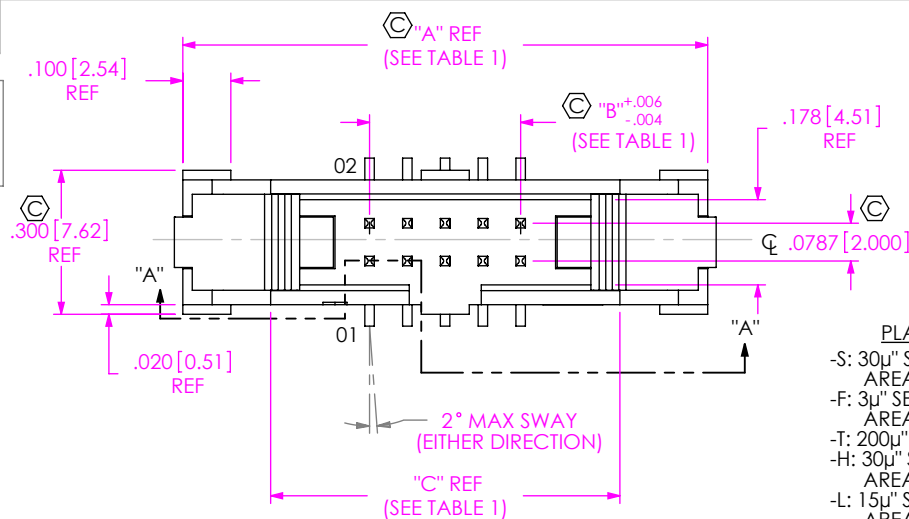

No OF POSITIONS  
-05 THRU -25

LEAD STYLE  
-01

**PLATING SPECIFICATION**  
 -S: 30μ" SELECTIVE GOLD IN CONTACT AREA, MATTE TIN ON TAIL.  
 -F: 3μ" SELECTIVE GOLD IN CONTACT AREA, MATTE TIN ON TAIL.  
 -T: 200μ" MATTE TIN ON ENTIRE CONTACT.  
 -H: 30μ" SELECTIVE GOLD IN CONTACT AREA, 3μ" SELECTIVE GOLD ON TAIL.  
 -L: 15μ" SELECTIVE GOLD IN CONTACT AREA, MATTE TIN ON TAIL.

**ROW SPECIFICATION**  
 -D: DOUBLE

**OPTION 3**  
 -TR: TAPE & REEL

**OPTION 2**  
 -P: PICK & PLACE PAD (FOR -SM ONLY, USE PPP-24) (USE PPP-55 WITH -SM-TR OPTION) (SEE SHT 3, FIG 5) (NOT AVAILABLE WITH -LC)  
 -K: POLYIMIDE FILM PAD (SEE SHT 2, FIG 4) (NOT AVAILABLE WITH -LC) (FOR -SM ONLY)

**POLARIZATION OPTION**  
 -XX= PIN OMITTED

**OPTION 1**  
 -LC: LOCKING CLIP (SEE NOTE 8) (FOR -SM ONLY, SEE NOTE 8) (NOT AVAILABLE WITH -P OR -K)

**-SR STRAIN RELIEF**

**TAIL OPTION**  
 -RA: RIGHT ANGLE  
 -SM: SURFACE MOUNT (LEAVE BLANK FOR THRU HOLE)

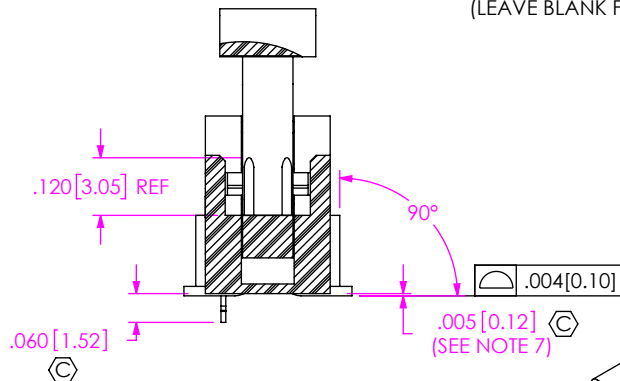
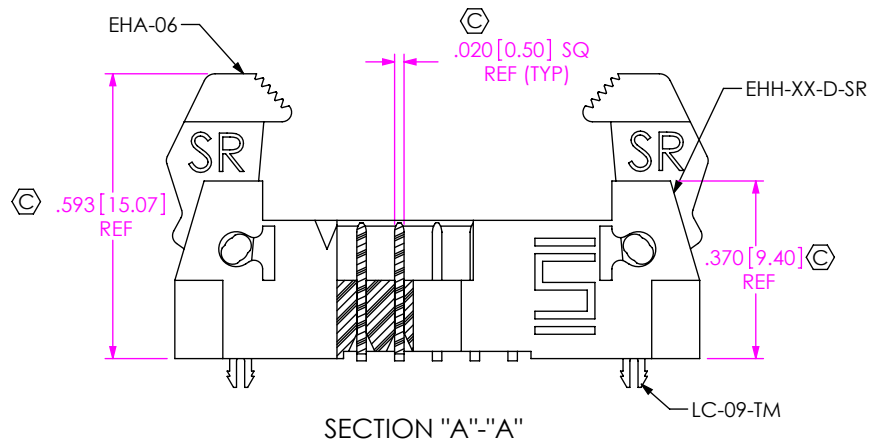
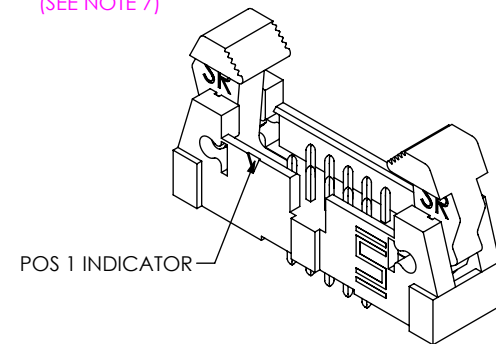
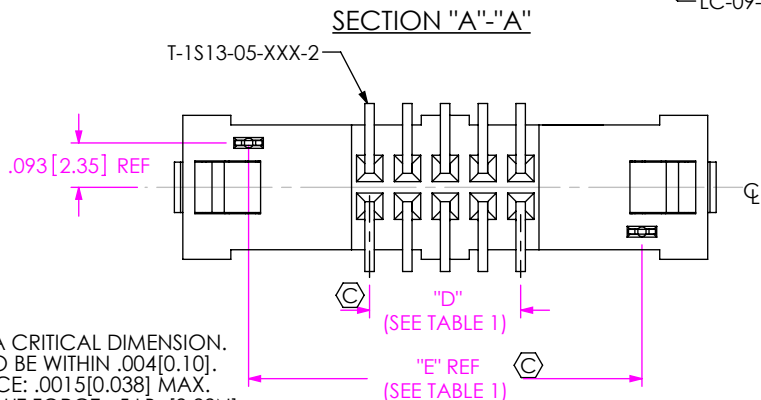

FIG 1  
(EHT-105-01-XX-D-SM-SR-LC SHOWN)



NOTES:

1. Ⓢ REPRESENTS A CRITICAL DIMENSION.
2. COPLANARITY TO BE WITHIN .004 [0.10].
3. BURR ALLOWANCE: .0015 [0.038] MAX.
4. MINIMUM PUSHOUT FORCE: .5 LB. [2.22N]
5. MAXIMUM ALLOWABLE BOW: .002 [0.05] INCH/INCH AFTER ASSEMBLY.
6. MAXIMUM PIN ROTATION IN BODY: 2°
7. MEASURE AT BEND
8. DUE TO THE HIGH AMOUNT OF INSERTION FORCE NEEDED, THE -LC OPTION IS NOT COMPATIBLE WITH AUTO PLACEMENT. SAMTEC RECOMMENDS MANUAL PLACEMENT FOR ALL ASSEMBLIES WITH THE -LC OPTION.

UNLESS OTHERWISE SPECIFIED, DIMENSIONS ARE IN INCHES. TOLERANCES ARE:  
 DECIMALS ANGLES  
 .XX: ±.01 [0.3] 2°  
 .XXX: ±.005 [0.13]  
 .XXXX: ±.0020 [0.051]

**PROPRIETARY NOTE**  
 THIS DOCUMENT CONTAINS CONFIDENTIAL AND PROPRIETARY INFORMATION AND ALL DESIGN, MANUFACTURING, REPRODUCTION, USE, PATENT RIGHTS AND SALES RIGHTS ARE EXPRESSLY RESERVED BY SAMTEC, INC. THIS DOCUMENT SHALL NOT BE DISCLOSED, IN WHOLE OR PART, TO ANY UNAUTHORIZED PERSON OR ENTITY NOR REPRODUCED, TRANSFERRED OR INCORPORATED IN ANY OTHER PROJECT IN ANY MANNER WITHOUT THE EXPRESS WRITTEN CONSENT OF SAMTEC, INC.



520 PARK EAST BLVD, NEW ALBANY, IN 47150  
 PHONE: 812-944-6733 FAX: 812-948-5047  
 e-Mail: info@SAMTEC.com code: 55322

**MATERIAL:** DO NOT SCALE DRAWING SHEET SCALE: 5:2  
 INSULATOR: VECTRA E130, COLOR: NATURAL  
 TERMINAL: PHOS BRONZE  
 MAX FLASH ALLOWED: .002 [0.05]  
 MAX GATE VESTIGE: .002 [0.05]

**DESCRIPTION:**  
 EHT EJECTOR HEADER ASSEMBLY  
 DWG. NO.  
 EHT-1XX-01-X-D-XX-SR-XX-XX-X-XX  
 BY: CHADP 08/04/2008 SHEET 1 OF 3

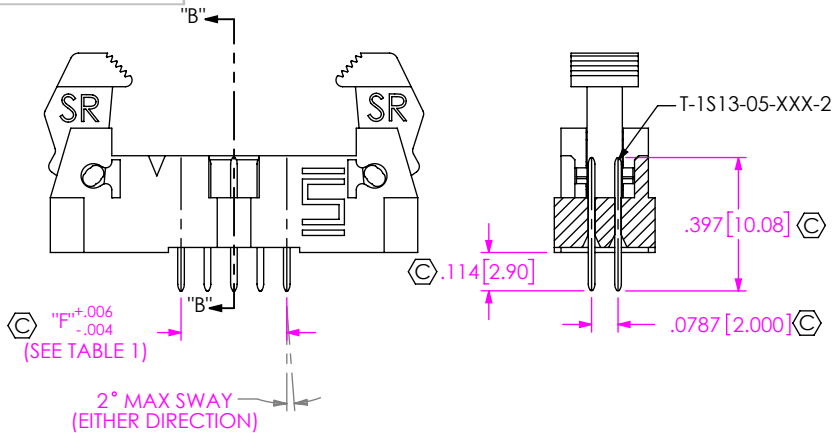

FIG 2  
(EHT-105-01-XX-D-SR SHOWN)  
(SAME AS FIG 1 DIFFERENT AS SHOWN)

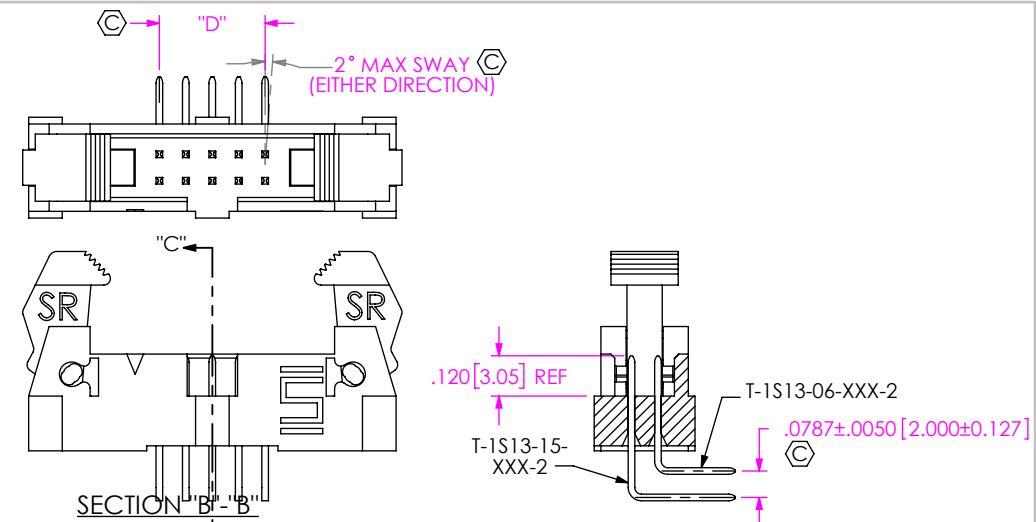
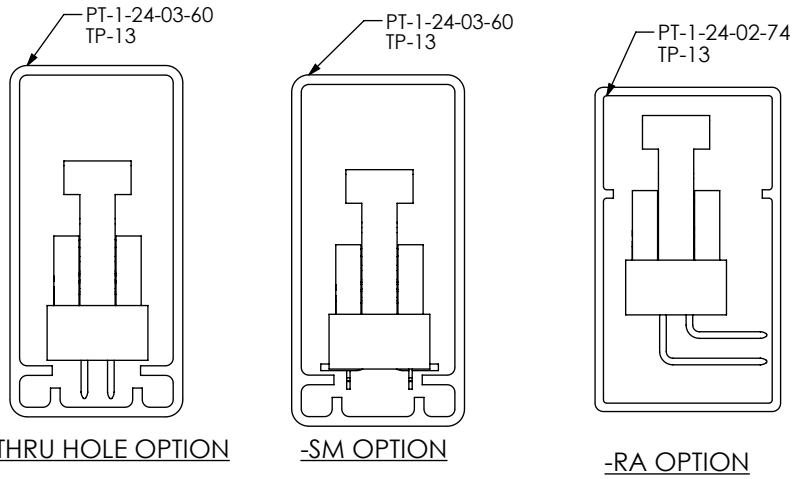

FIG 3  
(EHT-105-01-XX-D-RA-SR SHOWN)  
(SAME AS FIG 1 DIFFERENT AS SHOWN)



PACKAGING VIEWS  
(LOAD PARTS WITH POSITION #1 INDICATOR  
IN SAME DIRECTION AS ARROW ON TUBE)

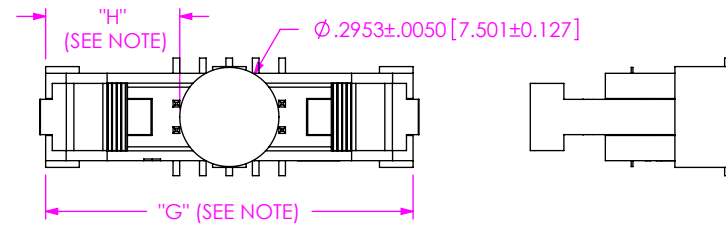
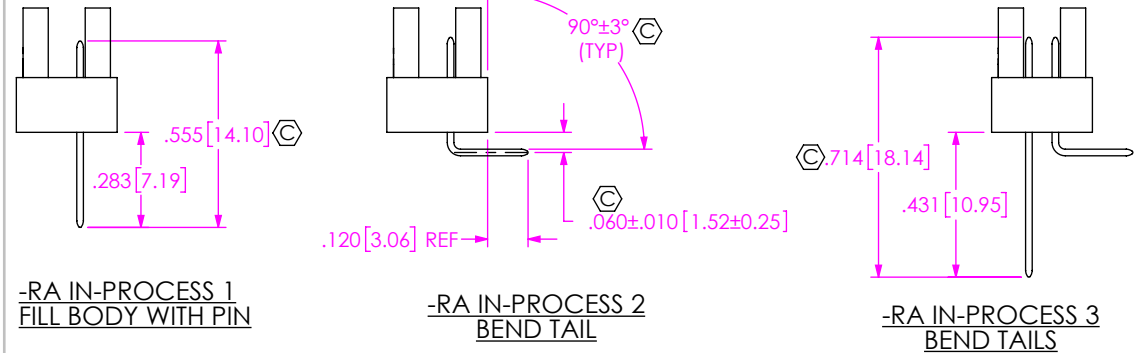
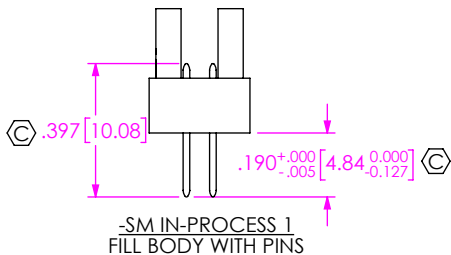
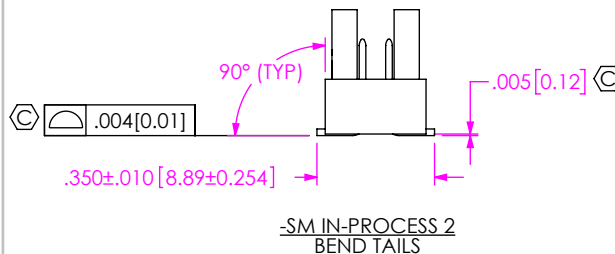

FIG 4  
-K: OPTION (POLYIMIDE FILM PAD)  
(SAME AS FIG 1 DIFFERENT AS SHOWN)  
NOTE: "G" = USE MEASURED DIMENSION (REF)  
"H" = {"G" -.2953[7.50]}/2 ±.020[0.51]}



-SM IN-PROCESS 1  
FILL BODY WITH PINS



-SM IN-PROCESS 2  
BEND TAILS

**PROPRIETARY NOTE**  
THIS DOCUMENT CONTAINS CONFIDENTIAL AND PROPRIETARY INFORMATION AND ALL DESIGN, MANUFACTURING, REPRODUCTION, USE, PATENT RIGHTS AND SALES RIGHTS ARE EXPRESSLY RESERVED BY SAMTEC, INC. THIS DOCUMENT SHALL NOT BE DISCLOSED, IN WHOLE OR PART, TO ANY UNAUTHORIZED PERSON OR ENTITY NOR REPRODUCED, TRANSFERRED OR INCORPORATED IN ANY OTHER PROJECT IN ANY MANNER WITHOUT THE EXPRESS WRITTEN CONSENT OF SAMTEC, INC.

DO NOT SCALE DRAWING

SHEET SCALE: 1:75:1



520 PARK EAST BLVD, NEW ALBANY, IN 47150  
PHONE: 812-944-6733 FAX: 812-948-5047  
e-Mail: info@SAMTEC.com code: 55322

DESCRIPTION: EHT EJECTOR HEADER ASSEMBLY  
DWG. NO. EHT-1XX-01-X-D-XX-SR-XX-XX-X-XX  
BY: CHADP 08/04/2008 SHEET 2 OF 3

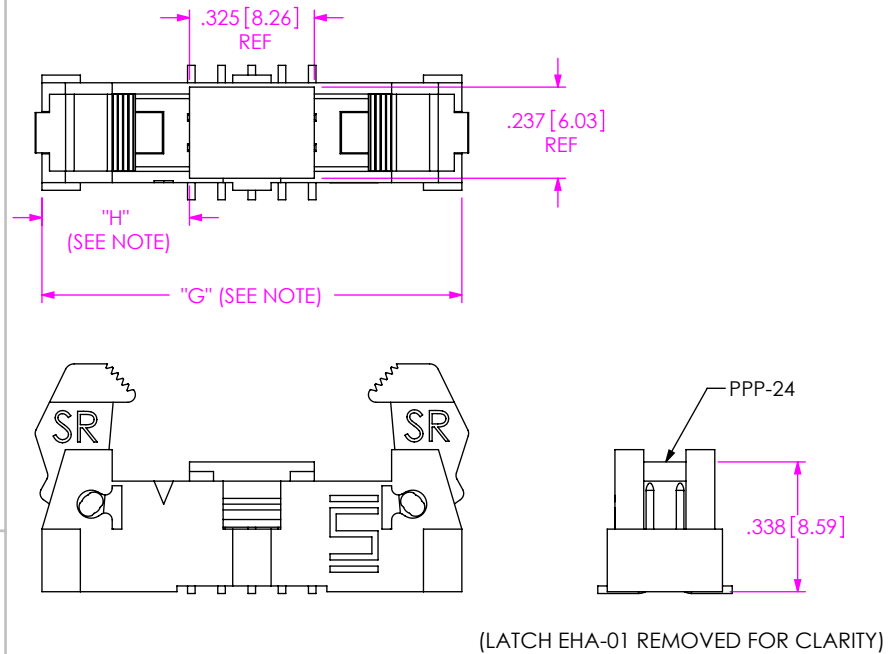
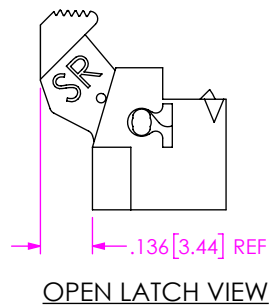
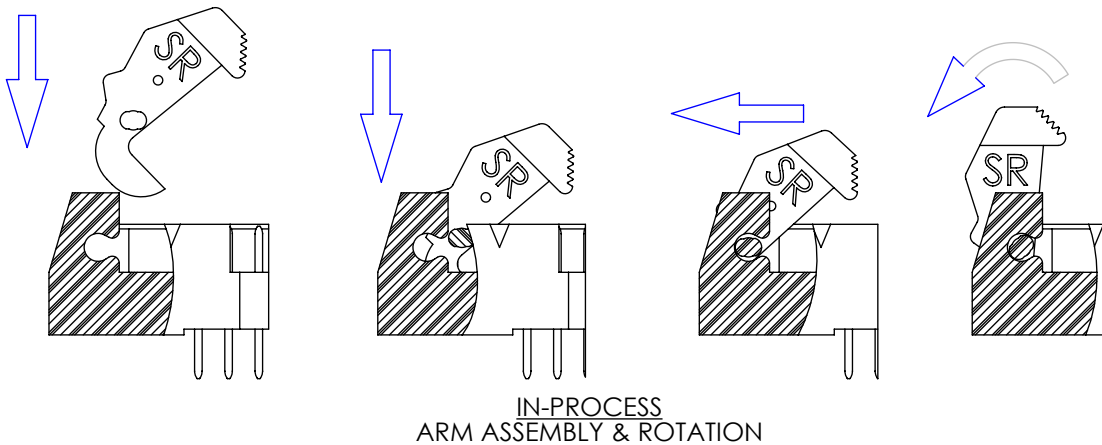

FIG 5  
-PPP: PICK AND PLACE PAD  
(SAME AS FIG 1 DIFFERENT AS SHOWN)

NOTE: "G" = USE MEASURED DIMENSION (REF)  
"H" = {"G" -.325[8.26]/2} ±.020[0.51]

**TABLE 1**

No. OF POS.	"A"	"B"	"C"	"D"	"E"	"F"
-05	1.094 [27.79]	0.315 [8.00]	.728 [18.49]	0.315 [8.00]	0.820 [20.83]	0.315 [8.00]
-06	1.173 [29.79]	0.394 [10.00]	.807 [20.49]	0.394 [10.00]	0.899 [22.83]	0.394 [10.00]
-07	1.251 [31.79]	0.472 [12.00]	.885 [22.49]	0.472 [12.00]	0.977 [24.83]	0.472 [12.00]
-08	1.330 [33.79]	0.551 [14.00]	.964 [24.49]	0.551 [14.00]	1.056 [26.83]	0.551 [14.00]
-09	1.409 [35.79]	0.630 [16.00]	1.043 [26.49]	0.630 [16.00]	1.135 [28.83]	0.630 [16.00]
-10	1.488 [37.79]	0.709 [18.00]	1.122 [28.49]	0.709 [18.00]	1.214 [30.83]	0.709 [18.00]
-11	1.566 [39.79]	0.787 [20.00]	1.200 [30.49]	0.787 [20.00]	1.292 [32.83]	0.787 [20.00]
-12	1.645 [41.79]	0.866 [22.00]	1.279 [32.49]	0.866 [22.00]	1.371 [34.83]	0.866 [22.00]
-13	1.724 [43.78]	0.945 [24.00]	1.358 [34.49]	0.945 [24.00]	1.450 [36.83]	0.945 [24.00]
-14	1.803 [45.78]	1.023 [26.00]	1.437 [36.49]	1.023 [26.00]	1.529 [38.83]	1.023 [26.00]
-15	1.881 [47.78]	1.102 [28.00]	1.515 [38.49]	1.102 [28.00]	1.607 [40.83]	1.102 [28.00]
-16	1.960 [49.78]	1.181 [30.00]	1.594 [40.49]	1.181 [30.00]	1.686 [42.83]	1.181 [30.00]
-17	2.039 [51.78]	1.260 [32.00]	1.673 [42.49]	1.260 [32.00]	1.765 [44.83]	1.260 [32.00]
-18	2.117 [53.78]	1.338 [34.00]	1.752 [44.49]	1.338 [34.00]	1.844 [46.83]	1.338 [34.00]
-19	2.196 [55.78]	1.417 [36.00]	1.830 [46.49]	1.417 [36.00]	1.922 [48.83]	1.417 [36.00]
-20	2.275 [57.78]	1.496 [38.00]	1.909 [48.49]	1.496 [38.00]	2.001 [50.83]	1.496 [38.00]
-21	2.353 [59.78]	1.575 [40.00]	1.988 [50.49]	1.575 [40.00]	2.080 [52.83]	1.575 [40.00]
-22	2.432 [61.78]	1.653 [42.00]	2.067 [52.49]	1.653 [42.00]	2.159 [54.83]	1.653 [42.00]
-23	2.511 [63.77]	1.732 [44.00]	2.145 [54.49]	1.732 [44.00]	2.237 [56.83]	1.732 [44.00]
-24	2.590 [65.77]	1.811 [46.00]	2.224 [56.49]	1.811 [46.00]	2.316 [58.83]	1.811 [46.00]
-25	2.668 [67.77]	1.890 [48.00]	2.303 [58.49]	1.890 [48.00]	2.395 [60.83]	1.890 [48.00]

\* PROPRIETARY NOTE \*

THIS DOCUMENT CONTAINS CONFIDENTIAL AND PROPRIETARY INFORMATION AND ALL DESIGN, MANUFACTURING, REPRODUCTION, USE, PATENT RIGHTS AND SALES RIGHTS ARE EXPRESSLY RESERVED BY SAMTEC, INC. THIS DOCUMENT SHALL NOT BE DISCLOSED, IN WHOLE OR PART, TO ANY UNAUTHORIZED PERSON OR ENTITY NOR REPRODUCED, TRANSFERRED OR INCORPORATED IN ANY OTHER PROJECT IN ANY MANNER WITHOUT THE EXPRESS WRITTEN CONSENT OF SAMTEC, INC.

DO NOT SCALE DRAWING

SHEET SCALE: 2:1



520 PARK EAST BLVD, NEW ALBANY, IN 47150  
PHONE: 812-944-6733 FAX: 812-948-5047  
e-Mail: info@SAMTEC.com code: 53322

DESCRIPTION: EHT EJECTOR HEADER ASSEMBLY

DWG. NO. EHT-1XX-01-X-D-XX-SR-XX-XX-X-XX

BY: CHADP 08/04/2008 SHEET 3 OF 3