

Device connector, rear mounting - RC-19P1NX241JS - 1602734

Please be informed that the data shown in this PDF Document is generated from our Online Catalog. Please find the complete data in the user's documentation. Our General Terms of Use for Downloads are valid (<http://phoenixcontact.com/download>)



Device connector for rear wall, RC, straight, Screw locking, M23, Flat gasket, 4xM3, Panel thickness min.: 2.7 mm, Panel thickness max.: 3.5 mm

The figure shows the 12-pos. product version



Key Commercial Data

Packing unit	20 pc
GTIN	
GTIN	4046356241274

Technical data

Housing data

Housing material	Metal
Type of locking	Screw locking
Degree of protection (when plugged in)	IP67
Thread type	M23

Environmental Product Compliance

REACH SVHC	Lead 7439-92-1
China RoHS	Environmentally Friendly Use Period = 50 years
	For details about hazardous substances go to tab "Downloads", Category "Manufacturer's declaration"

Drawings

Device connector, rear mounting - RC-19P1NX241JS - 1602734

Dimensional drawing

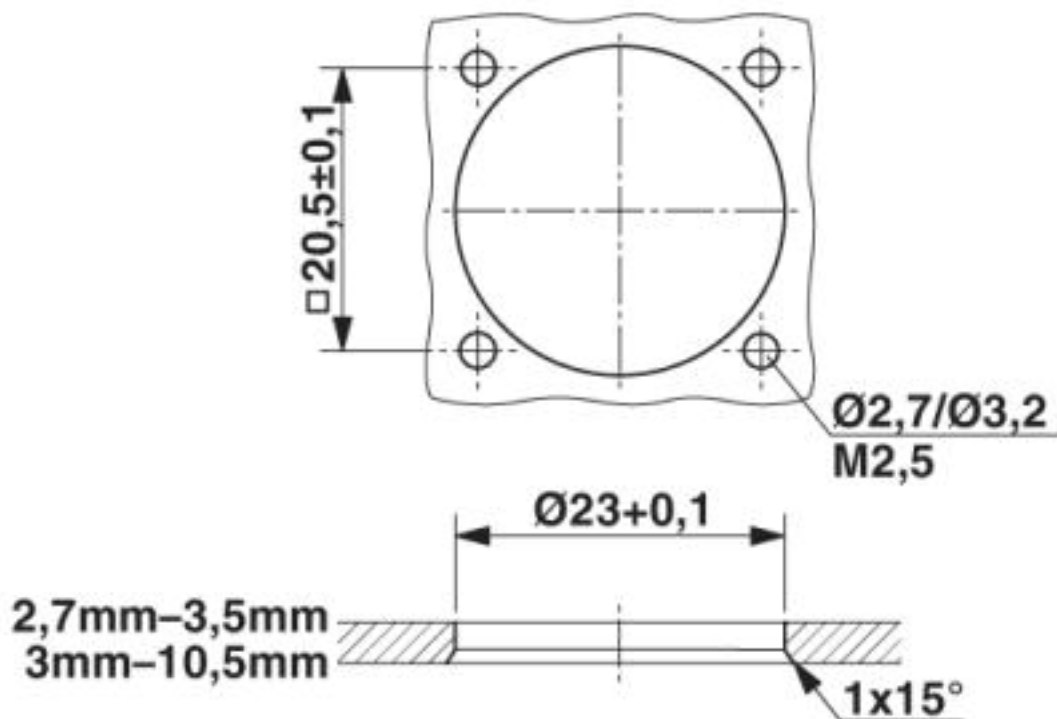

Installation dimensions

Classifications

eCl@ss

eCl@ss 10.0.1	27440102
eCl@ss 4.0	27260700
eCl@ss 4.1	27260700
eCl@ss 5.0	27260700
eCl@ss 5.1	27260700
eCl@ss 6.0	27279200
eCl@ss 7.0	27440103
eCl@ss 8.0	27440103
eCl@ss 9.0	27440102

ETIM

ETIM 3.0	EC001121
ETIM 4.0	EC001121
ETIM 5.0	EC001121
ETIM 6.0	EC001121
ETIM 7.0	EC001121

Device connector, rear mounting - RC-19P1NX241JS - 1602734

Classifications

UNSPSC

UNSPSC 6.01	43172015
UNSPSC 7.0901	43201404
UNSPSC 11	43172015
UNSPSC 12.01	43201404
UNSPSC 13.2	39121413
UNSPSC 18.0	39121413
UNSPSC 19.0	39121413
UNSPSC 20.0	39121413
UNSPSC 21.0	39121413

Approvals

Approvals

Approvals

EAC

Ex Approvals

Approval details

EAC		B.01687
-----	---	---------

Phoenix Contact 2020 © - all rights reserved
<http://www.phoenixcontact.com>

PHOENIX CONTACT GmbH & Co. KG
Flachsmarktstr. 8
32825 Blomberg
Germany
Tel. +49 5235 300
Fax +49 5235 3 41200
<http://www.phoenixcontact.com>