

PART NUMBER	CKT. SIZE	DIM A	DIM D	COVER	PACKAGING	PEG
87381-4488	44	42.00	40.00	NO	TUBE	YES
87381-4489	44	42.00	40.00	YES	TAPE/REEL	YES
87381-4487	44	42.00	40.00	YES	TUBE	YES
87381-4486	44	42.00	40.00	YES	TAPE/REEL	NO
87381-4485	44	42.00	40.00	YES	TUBE	NO

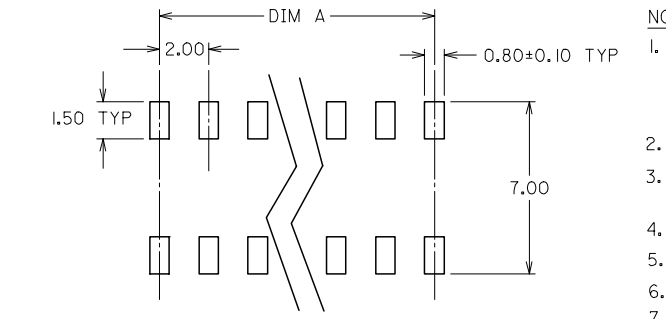

- NOTES:
- PLATING FINISH :
0.38um MIN. GOLD IN CONTACT AREA
1.27um MIN. TIN IN SOLDER TAIL AREA
BOTH OVER 1.27um MIN NI OVEALL
 - PRODUCT SPECIFICATION PS-87380 APPLIES
 - COPLANARITY OF SOLDER TAILS ARE TO BE MEASURED BY RESTING THE PART ON A FLAT GAUGE SURFACE
 - PACKAGING SEE SHEET 2 OF 2
 - TERMINAL FULLY LOADED
 - PART WITH COVER & PEG SHOWN FOR ILLUSTRATION.
 - PARTS SHALL BE PACKED IN MOISTURE BARRIER BAG.

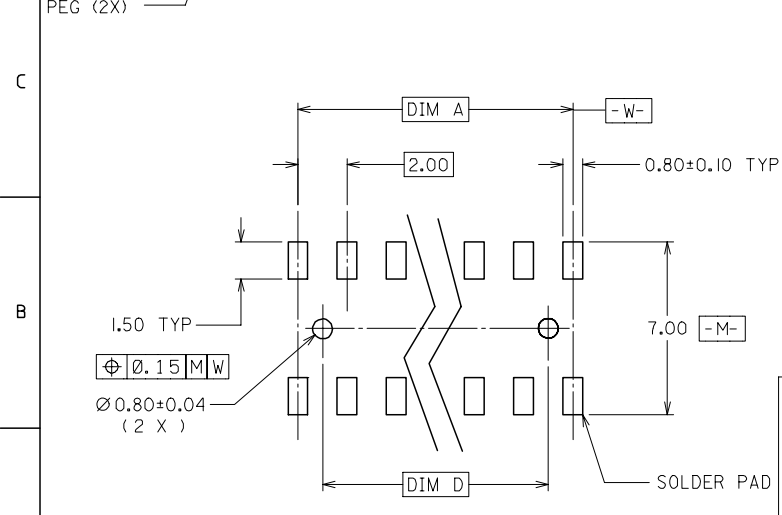
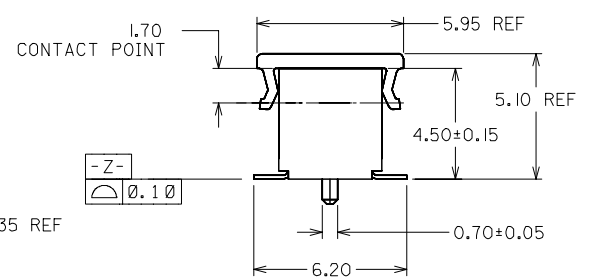
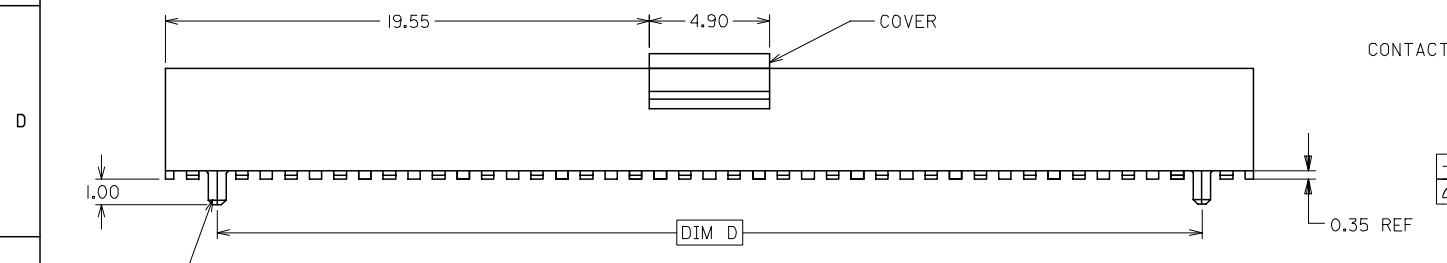
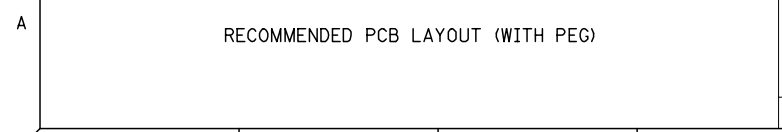

RECOMMENDED PCB LAYOUT (WITHOUT PEG)

ADD NOTE 7. EC NO: S2008-0281 DRWNS:KANG 2007/10/31 CHKD:ATSEE 2007/11/01 APPR:MLONG 2007/11/01	QUALITY SYMBOLS ▽=0 ▽=0	GENERAL TOLERANCES (UNLESS SPECIFIED)		DIMENSION STYLE MM ONLY		SCALE NTS	DESIGN UNITS METRIC	THIRD ANGLE PROJECTION	
				mm	INCH	DRAWN BY RSHAN	DATE 1999/01/11	TITLE MGRID 2MM RECEPTACLE 44 CKTS, 4.50MM HT.	
D1	REV	4 PLACES	± ---	± ---	APPROVED BY JSGOH	DATE 1999/11/16	MATERIAL NO. SKT0H		
		3 PLACES	± ---	± ---	DATE 1999/01/17	DOCUMENT NO. SD-87381-4498			
DRAFT WHERE APPLICABLE MUST REMAIN WITHIN DIMENSIONS		ANGULAR ± 3 °		SEE TABLE		SHEET NO. 1 OF 2		MOLEX INCORPORATED	

THIS DRAWING CONTAINS INFORMATION THAT IS PROPRIETARY TO MOLEX INCORPORATED AND SHOULD NOT BE USED WITHOUT WRITTEN PERMISSION

10 9 8 7 6 5 4 3 2 1

F

E

D

C

B

A

F

E

D

C

B

A

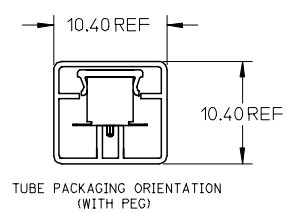
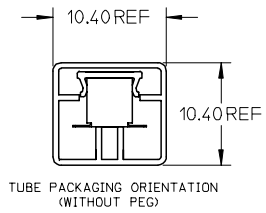
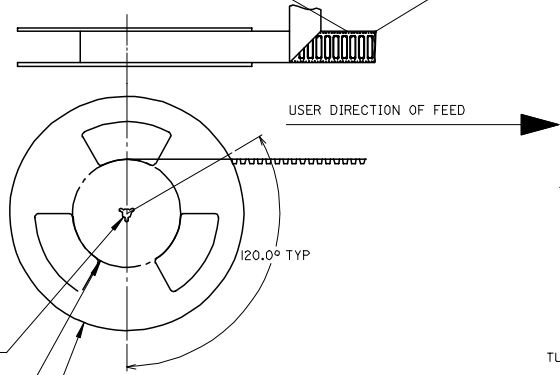
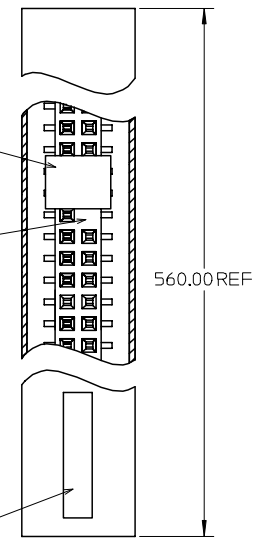
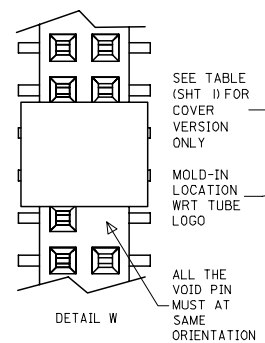
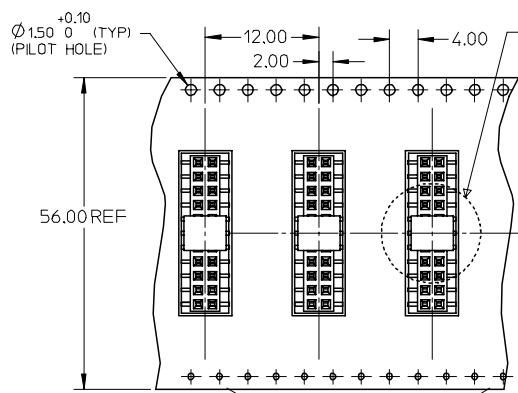

TAPE AND REEL ORIENTATION (NOT TO SCALE) 22 CKT SHOWN FOR ILLUSTRATION ONLY

NOTES:

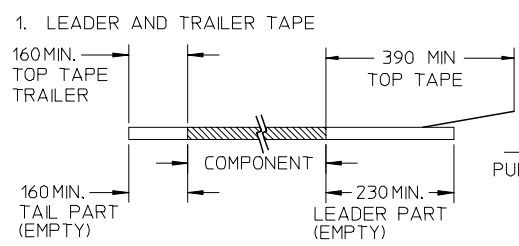

2. PEELING OFF FORCE OF THE TOP TAPE: 20-80gf. (PEELING DIRECTION AS SHOWN IN FOLLOWING FIGURE)

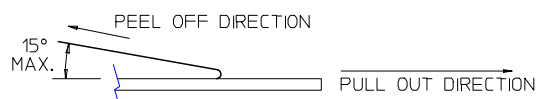

3. PACKAGING STANDARD IS AS PER EIA-481.
4. TAPE & REEL QUANTITY = 800 PCS/REEL

ADD NOTE 7. EC NO: S2008-0281 DRWNS:KANG 2007/10/31 CHKD:ATSEE 2007/11/01 APPR:MLONG 2007/11/01	DESCRIPTION	QUALITY SYMBOLS	GENERAL TOLERANCES (UNLESS SPECIFIED)	DIMENSION STYLE	SCALE	DESIGN UNITS	THIRD ANGLE PROJECTION
	REV	▽=0 ∇=0		MM ONLY	NTS	METRIC	
			4 PLACES ± --- ± --- 3 PLACES ± --- ± --- 2 PLACES ± 0.20 ± --- 1 PLACE ± --- ± ---				
	D1		ANGULAR ± 3°				

DRAWN BY	DATE	TITLE
RSHAN	1999/01/11	MGRID 2MM RECEPTACLE 44 CKTS, 4.50MM HT.
CHECKED BY	DATE	
JSGOH	1999/11/16	
APPROVED BY	DATE	
SKTOH	1999/01/17	
MATERIAL NO.	DOCUMENT NO.	SHEET NO.
SEE TABLE	SD-87381-4498	2 OF 2

SIZE	THIS DRAWING CONTAINS INFORMATION THAT IS PROPRIETARY TO MOLEX INCORPORATED AND SHOULD NOT BE USED WITHOUT WRITTEN PERMISSION	
A3		

9 8 7 6 5 4 3 2 1