

PRODUCT NO.  
SEE TABLE

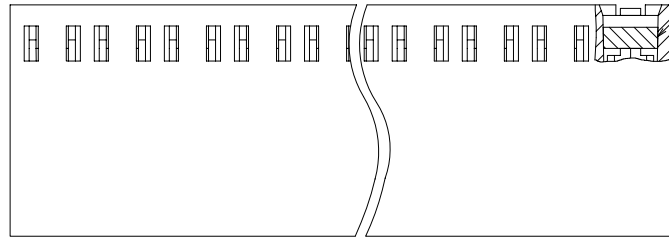

OPTIONAL  
INSULATION  
PLUG

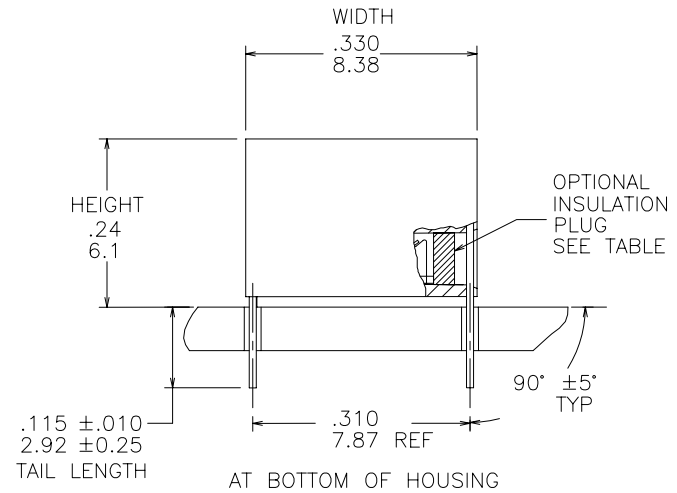
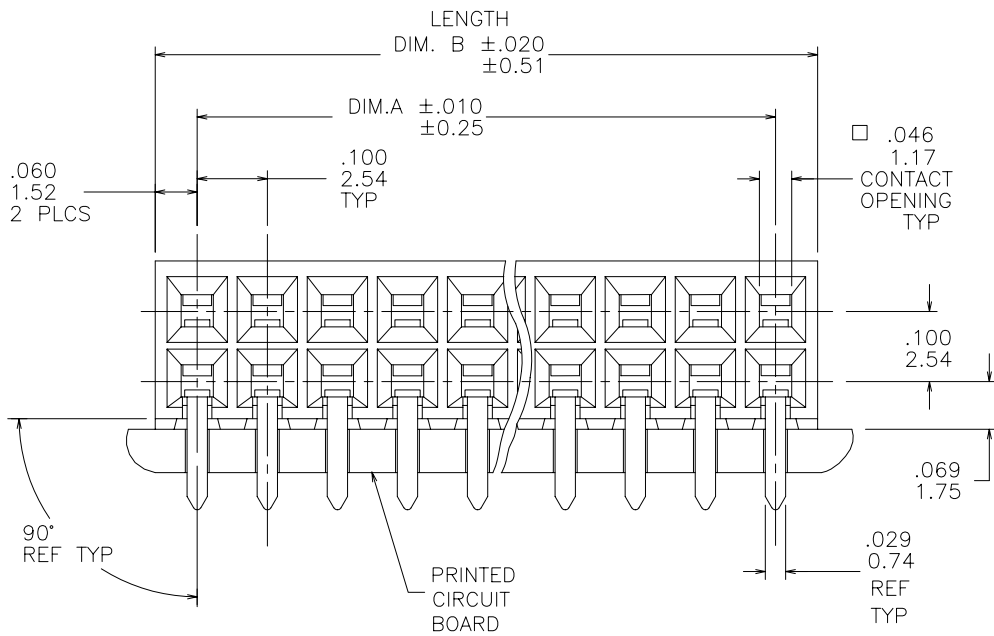

Copyright FCI

mat'l. code		surface		tolerance		projection		product family	
-		ISO 1302 <input checked="" type="checkbox"/>		ISO 406				CARD CONN.	
				ISO 1101					
tr		ecn no		date		tolerances unless otherwise specified		title	
H	C30134	MRC	6/9/93	angles		.xx $\pm 0.1/3$		HORIZ. CARD CONN.	
J	V61633	EPK	11/14/96	linear		.xxx $\pm 0.05/.13$		D/R .100/2.54 CL	
K	V70746	EPK	4/24/97	0'±2'		.xxxx $\pm 0.020/.051$		scale 4:1	
L	V70994	JM	10/19/97	dr		J. SHREINER 3/23/90		dwg no	
M	V02523	AZ	10/25/00	enfr		M. HAHN 3/23/90		sheet 1 of 7 size	
N	M05-0245	MHT	11/23/05	chr		M. HAHN 3/23/90		66925 A3	
P	M07-0137	MHT	2/26/07	appd		M. HAHN 3/23/90		type Product Customer Drawing	
sheet	revision	P	P	P	P	P	P		
index	sheet	1	2	3	4	5	6	7	

form: A3

PRODUCT NO.  
SEE TABLE

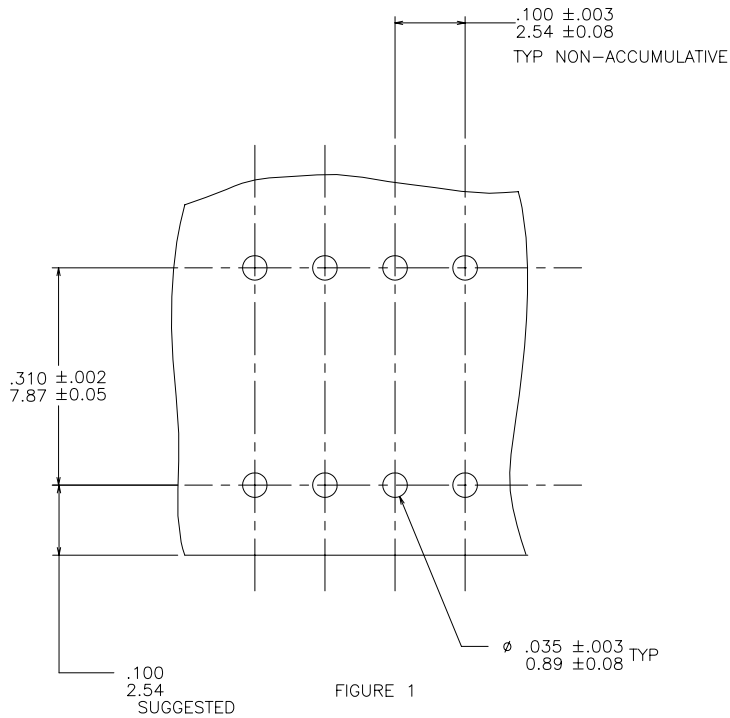

FIGURE 1

NOTES.

1. HOUSING MATERIAL.  
FILLED HIGH TEMPERATURE NYLON.  
PER UL 94V-0  
COLOR. BLACK
2. TERMINAL MATERIAL.  
BODY. BRASS .010/0.25 THICK.  
SPRING. BE-CU. HEAT TREATED  
BODY PLATING.  
30 MICROINCH GOLD/0.76 MICRO OVER 50 MICROINCH  
NICKEL/1.27 MICRON IN CONTACT AREA.  
SOLDER TAIL: 100u" PURE TIN (NOTE 9) OVER .050u" NICKEL.  
SPRING PLATING. GOLD FLASH
3. MARK "FCI" FCI PART NUMBER AND DATE CODE  
LEGIBLE ON TUBE LABEL.
4. APPLICATION INFORMATION.  
A. RECOMMENDED MOUNTING HOLE PATTERN IS SHOWN IN  
FIG. "1".  
B. ALL MATING PINS TO BE .025/0.64 SQUARE ON TRUE CENTER  
OF GIVEN TERMINAL SPACINGS WITHIN .015/0.38 DIA.  
C. SUGGESTED MATING PIN LENGTH .350±.020/8.89±0.51.
5. SOLDER TAIL TO HAVE GOLD FLASH OVER .050u" NICKEL.
- ⑥ ADD "LF" SUFFIX AT THE END OF PART NUMBER FOR LEAD  
FREE OPTION.
- ⑦ THESE PRODUCT MEETS EUROPEAN UNION DIRECTIVES AND OTHER  
COUNTRY REGULATIONS AS DESCRIBED IN GS-22-008
8. THIS PART WILL WITHSTAND EXPOSURE TO 260°C PEAK TEMPERATURE  
FOR 20 SECONDS IN A WAVE SOLDER, INFRA-RED OR VAPOR PHASE  
SOLDER PROCESS.
- ⑨ THIS PRODUCT HAS 100% TIN PLATING IN THE INTERFACE AND  
HAS NOT BEEN TESTED FOR WISKER GROWTH IN ALL INTERCONNECT  
REQUIREMENTS



FCIconnect.com

Copyright FCI

mat'l. code		surface		tolerance		projection		product family	
-		ISO 1302 ✓		ISO 406		⊕		CARD CONN.	
ISO 1101		tolerances unless otherwise specified		INCH/MM		title			
ltr		ecn		no		dr		date	
P									
angles		linear		.xx ±.01/.3		scale 4:1		HORIZ. CARD CONN.	
0°±2'				.xxx ±.005/.13				D/R .100/2.54 CL	
				.xxx ±.0020/.051				dwg no	
dr		J. SHREINER		3/23/90		FCI		sheet 2 of 7	
enfr		M. HAHN		3/23/90				66925	
chr		M. HAHN		3/23/90				A3	
appd		M. HAHN		3/23/90				type Product Customer Drawing	
sheet		revision							
index		sheet							

form: A3

PRODUCT NUMBER	NO. OF POS.	DIM. A	DIM. B	INSULATION PLUG	LEAD FREE OPTION
66925-001	2X1	.00/.0	.120/3.05	NO	UNASSIGNED
-002	2X2	.10/2.5	.220/5.59		UNASSIGNED
-003	2X3	.20/5.0	.320/8.13		NOTE 5
-004	2X4	.30/7.6	.420/10.67		NOTE 5
-005	2X5	.40/10.1	.520/13.21		
-006	2X6	.50/12.7	.620/15.75		
-007	2X7	.60/15.2	.720/18.27		
-008	2X8	.70/17.7	.820/20.83		
-009	2X9	.80/20.3	.920/23.37		
-010	2X10	.90/22.8	1.020/25.91		
-011	2X11	1.00/25.4	1.120/28.45		
-012	2X12	1.10/27.9	1.220/30.99		
-013	2X13	1.20/30.4	1.320/33.53		
-014	2X14	1.30/33.0	1.420/36.07		
-015	2X15	1.40/35.5	1.520/38.61		
-016	2X16	1.50/38.1	1.620/41.15		
-017	2X17	1.60/40.6	1.720/43.69		
-018	2X18	1.70/43.1	1.820/46.23		
-019	2X19	1.80/45.7	1.920/48.77		
-020	2X20	1.90/48.2	2.020/51.31		
-021	2X21	2.00/50.8	2.120/53.85		
-022	2X22	2.10/53.3	2.220/56.39		
-023	2X23	2.20/55.8	2.320/58.93		
-024	2X24	2.30/58.4	2.420/61.47		
-025	2X25	2.40/60.9	2.520/64.01		
-026	2X26	2.50/63.5	2.620/66.55		
-027	2X27	2.60/66.0	2.720/69.09		
-028	2X28	2.70/68.5	2.820/71.63		
-029	2X29	2.80/71.1	2.920/74.17		
-030	2X30	2.90/73.6	3.020/76.71		
-031	2X31	3.00/76.2	3.120/79.25		
-032	2X32	3.10/78.7	3.220/81.79		
-033	2X33	3.20/81.2	3.320/84.33		
-034	2X34	3.30/83.8	3.420/86.87		
-035	2X35	3.40/86.3	3.520/89.41		
-036	2X36	3.50/88.9	3.620/91.95		
-037	2X37	3.60/91.4	3.720/94.49		
-038	2X38	3.70/93.9	3.820/97.03		
-039	2X39	3.80/96.5	3.920/99.57		
66925-040	2X40	3.90/99.0	4.020/102.11	NO	NOTE 6,7

NOTE 6,7

UNASSIGNED  
UNASSIGNED  
NOTE 5  
NOTE 5



FCIconnect.com

Copyright FCI

mat'l. code		surface		tolerance		projection		product family	
-		ISO 1302 ✓		ISO 406		ISO 1101		CARD CONN.	
ltr	ecn	no	dr	date	tolerances unless otherwise specified			title	
P					angles	linear	.xx ±.01/.3	HORIZ. CARD CONN.	
					0'±2'		.xxx ±.005/.13	D/R .100/2.54 CL	
							.xxx ±.0020/.051	scale 4:1	
					dr	J. SHREINER	3/23/90	dwg no	
					enr	M. HAHN	3/23/90	sheet 3 of 7 size	
					chr	M. HAHN	3/23/90	66925 A3	
					appd	M. HAHN	3/23/90	type Product Customer Drawing	
sheet index	revision sheet								



PRODUCT NUMBER	NO. OF POS.	DIM. A	DIM. B	INSULATION PLUG	LEAD FREE OPTION
66925-041	2X41	4.00/101.6	4.120/104.65	NO	NOTE 6,7
-042	2X42	4.10/104.1	4.220/107.19		
-043	2X43	4.20/106.6	4.320/109.73		
-044	2X44	4.30/109.2	4.420/112.27		
-045	2X45	4.40/111.7	4.520/114.81		
-046	2X46	4.50/114.3	4.620/117.35		
-047	2X47	4.60/116.8	4.720/119.89		
-048	2X48	4.70/119.3	4.820/122.43		
-049	2X49	4.80/121.9	4.920/124.97		
-050	2X50	4.90/124.4	5.020/127.51		
-051	2X51	5.00/127.0	5.120/130.05		
-052	2X52	5.10/129.5	5.220/132.59		
-053	2X53	5.20/132.0	5.320/135.15		
-054	2X54	5.30/134.6	5.420/137.67		
-055	2X55	5.40/137.1	5.520/140.21		
-056	2X56	5.50/139.7	5.620/142.76		
-057	2X57	5.60/142.2	5.720/145.29		
-058	2X58	5.70/144.7	5.820/147.83		
-059	2X59	5.80/147.3	5.920/150.37		
-060	2X60	5.90/149.8	6.020/152.91		
-061	2X61	6.00/152.4	6.120/155.45		
-062	2X62	6.10/154.9	6.220/157.99		
-063	2X63	6.20/157.4	6.320/160.53		
-064	2X64	6.30/160.0	6.420/163.07		
66925-065	2X65	6.40/162.5	6.520/165.61	NO	NOTE 6,7
-066 THRU					OBSOLETE
-100					



FCJconnect.com

Copyright FCJ

mat'l. code		surface		tolerance		projection		product family	
-		ISO 1302		ISO 406				CARD CONN.	
ltr		ecn no/dr		date		tolerances unless otherwise specified		title	
P						.xx ±.01/.3 .xxx ±.005/.13 .xxxx ±.0020/.051		INCH/MM scale 4:1	
				0'±2'				HORIZ. CARD CONN. D/R .100/2.54 CL	
				dr		J. SHREINER		3/23/90	
				enr		M. HAHN		3/23/90	
				chr		M. HAHN		3/23/90	
				appd		M. HAHN		3/23/90	
sheet		revision							
index		sheet						dwg no 66925 sheet 4 of 7 size A3 type Product Customer Drawing	

form: A3

PRODUCT NUMBER	NO. OF POS.	DIM. A	DIM. B	INSULATION PLUG	LEAD FREE OPTION
66925-501	2X1	.00/.0	.120/3.05	YES	
-502	2X2	.10/2.5	.220/5.59		
-503	2X3	.20/5.0	.320/8.13	YES	
-504	2X4	.30/7.6	.420/10.67		
-505	2X5	.40/10.1	.520/13.21		
-506	2X6	.50/12.7	.620/15.75		
-507	2X7	.60/15.2	.720/18.27		
-508	2X8	.70/17.7	.820/20.83		
-509	2X9	.80/20.3	.920/23.37		
-510	2X10	.90/22.8	1.020/25.91		
-511	2X11	1.00/25.4	1.120/28.45		
-512	2X12	1.10/27.9	1.220/30.99		
-513	2X13	1.20/30.4	1.320/33.53		
-514	2X14	1.30/33.0	1.420/36.07		
-515	2X15	1.40/35.5	1.520/38.61		
-516	2X16	1.50/38.1	1.620/41.15		
-517	2X17	1.60/40.6	1.720/43.69		
-518	2X18	1.70/43.1	1.820/46.23		
-519	2X19	1.80/45.7	1.920/48.77		
-520	2X20	1.90/48.2	2.020/51.31		
-521	2X21	2.00/50.8	2.120/53.85		
-522	2X22	2.10/53.3	2.220/56.39		
-523	2X23	2.20/55.8	2.320/58.93		
-524	2X24	2.30/58.4	2.420/61.47		
-525	2X25	2.40/60.9	2.520/64.01		
-526	2X26	2.50/63.5	2.620/66.55		
-527	2X27	2.60/66.0	2.720/69.09		
-528	2X28	2.70/68.5	2.820/71.63		
-529	2X29	2.80/71.1	2.920/74.17		
-530	2X30	2.90/73.6	3.020/76.71		
-531	2X31	3.00/76.2	3.120/79.25		
-532	2X32	3.10/78.7	3.220/81.79		
-533	2X33	3.20/81.2	3.320/84.33		
-534	2X34	3.30/83.8	3.420/86.87		
-535	2X35	3.40/86.3	3.520/89.41		
-536	2X36	3.50/88.9	3.620/91.95		
-537	2X37	3.60/91.4	3.720/94.49		
-538	2X38	3.70/93.9	3.820/97.03		
-539	2X39	3.80/96.5	3.920/99.57		
66925-540	2X40	3.90/99.0	4.020/102.11	YES	

UNASSIGNED  
UNASSIGNED  
NOTE 5  
NOTE 5

NOTE 6,7

NOTE 6,7



FCIconnect.com

Copyright FCI

mat'l. code		surface		tolerance		projection		product family	
-		ISO 1302 ✓		ISO 406		⊕		CARD CONN.	
ISO 1101		tolerances unless otherwise specified		linear		INCH/MM		title	
P		angles		.xx ±.01/.3		scale 4:1		HORIZ. CARD CONN.	
		0°±2'		.xxx ±.005/.13				D/R .100/2.54 CL	
				.xxxx ±.0020/.051				dwg no	
		dr		J. SHREINER		3/23/90		sheet 5 of 7	
		enfr		M. HAHN		3/23/90		size	
		chr		M. HAHN		3/23/90		A3	
		appd		M. HAHN		3/23/90		type	
								Product Customer Drawing	
sheet index		revision sheet							



PRODUCT NUMBER	NO. OF POS.	DIM. A	DIM. B	INSULATION PLUG	LEAD FREE OPTION
66925-541	2X41	4.00/101.6	4.120/104.65	YES	NOTE 6,7
-542	2X42	4.10/104.1	4.220/107.19		
-543	2X43	4.20/106.6	4.320/109.73		
-544	2X44	4.30/109.2	4.420/112.27		
-545	2X45	4.40/111.7	4.520/114.81		
-546	2X46	4.50/114.3	4.620/117.35		
-547	2X47	4.60/116.8	4.720/119.89		
-548	2X48	4.70/119.3	4.820/122.43		
-549	2X49	4.80/121.9	4.920/124.97		
-550	2X50	4.90/124.4	5.020/127.51		
-551	2X51	5.00/127.0	5.120/130.05		
-552	2X52	5.10/129.5	5.220/132.59		
-553	2X53	5.20/132.0	5.320/135.15		
-554	2X54	5.30/134.6	5.420/137.67		
-555	2X55	5.40/137.1	5.520/140.21		
-556	2X56	5.50/139.7	5.620/142.76		
-557	2X57	5.60/142.2	5.720/145.29		
-558	2X58	5.70/144.7	5.820/147.83		
-559	2X59	5.80/147.3	5.920/150.37		
-560	2X60	5.90/149.8	6.020/152.91		
-561	2X61	6.00/152.4	6.120/155.45		
-562	2X62	6.10/154.9	6.220/157.99		
-563	2X63	6.20/157.4	6.320/160.53		
-564	2X64	6.30/160.0	6.420/163.07		
66925-565	2X65	6.40/162.5	6.520/165.61	YES	NOTE 6,7
-566 THRU					
-600					

OBSOLETE



FCJconnect.com

Copyright FCJ

mat'l. code		surface		tolerance		projection		product family	
-		ISO 1302 ✓		ISO 406 ISO 1101				CARD CONN.	
ltr	ecn	no	dr	date		tolerances unless otherwise specified		title	
P						angles linear .xx ±.01/.3 .xxx ±.005/.13 .xxxx ±.0020/.051		INCH/MM scale 4:1 HORIZ. CARD CONN. D/R .100/2.54 CL	
dr		J. SHREINER		3/23/90				dwg no sheet 6 of 7 size 66925 A3	
enr		M. HAHN		3/23/90				type Product Customer Drawing	
chr		M. HAHN		3/23/90					
appd		M. HAHN		3/23/90					
sheet index	revision sheet								

form: A3

PRODUCT NUMBER	NO. OF POS.	DIM.A	DIM. B	INSUL. PLUG	SPECIAL MARKING	CUST. RESTR.	LEAD FREE OPTION
66925-800	2X50	4.90/124.4	5.02/127.5	NO	66925-800 104100110 DATE CODE	YES.	NOTE 6,7
66925-801	2X100	9.90/251.4	10.02/254.5	NO	66925-801 10410111 DATE CODE	YES.	OBSOLETE
66925-802	2X4	.30/7.6	.42/10.6	NO	FCI ↓	YES	
66925-803	2X6	.50/12.7	.62/15.7	NO	FCI ↓	YES	NOTE 5



Copyright FCI

mat'l. code		surface		tolerance		projection		product family	
-		ISO 1302 ✓		ISO 406 ISO 1101				CARD CONN.	
ltr	ecn	no	dr	date	tolerances unless otherwise specified		title		
P					angles	linear	INCH/MM		
					0°±2'	.xx ±.01/.3 .xxx ±.005/.13 .xxxx ±.0020/.051	scale 4:1		
					dr	J. SHREINER	3/23/90	dwg no	
					enfr	M. HAHN	3/23/90	sheet 7 of 7 size	
					chr	M. HAHN	3/23/90	66925 A3	
					appd	M. HAHN	3/23/90	type Product Customer Drawing	
sheet index	revision sheet								

