

# EMDS22J2H-160.000M TR [Click part number to visit Part Number Details page](#)

## REGULATORY COMPLIANCE (Data Sheet downloaded on Mar 27, 2018)



◀ Click badges to download compliance docs

Regulatory Compliance standards are subject to updates by governing bodies. Click the badges to download the latest compliance docs for this part number directly from Ecliptek.



## ITEM DESCRIPTION

MEMS Clock Oscillators LVDS (DS) 2.5Vdc 6 Pad 3.2mm x 5.0mm Plastic Surface Mount (SMD) 160.000MHz  $\pm$ 25ppm over -40°C to +85°C

## ELECTRICAL SPECIFICATIONS

Nominal Frequency	160.000MHz
Frequency Tolerance/Stability	$\pm$ 25ppm Maximum over -40°C to +85°C (Inclusive of all conditions: Calibration Tolerance at 25°C, Frequency Stability over the Operating Temperature Range, Supply Voltage Change, Output Load Change, First Year Aging at 25°C, Reflow, Shock, and Vibration)
Aging at 25°C	$\pm$ 1ppm Maximum First Year
Supply Voltage	2.5Vdc $\pm$ 5%
Input Current	75mA Maximum (Excluding Load Termination Current)
Output Voltage Logic High (Voh)	1.425Vdc Typical
Output Voltage Logic Low (Vol)	1.075Vdc Typical
Differential Output Error (dVod)	50mVdc Maximum
Differential Output Voltage (Vod)	247mVdc Minimum, 350mVdc Typical, 454mVdc Maximum
Offset Voltage (Vos)	1.125V Minimum, 1.250V Typical, 1.375V Maximum
Rise/Fall Time	225pSec Typical, 325pSec Maximum (Measured over 20% to 80% of waveform)
Duty Cycle	50 $\pm$ 5(%) (Measured at 50% of waveform)
Offset Error (dVos)	50mVdc Maximum
Load Drive Capability	100 Ohms Between Output and Complementary Output
Output Logic Type	LVDS
Logic Control / Additional Output	Output Enable (OE) and Complementary Output
Output Control Input Voltage	Vih of 70% of Vdd Minimum or No Connect to Enable Output and Complementary Output, Vil of 30% of Vdd Maximum to Disable Output and Complementary Output (High Impedance)
Output Enable Current	70mA Maximum (Without Load)
Period Jitter (Deterministic)	0.2pSec Typical
Period Jitter (Random)	2.0pSec Typical
Period Jitter (RMS)	2.5pSec Typical, 3.5pSec Maximum
Period Jitter (pk-pk)	25pSec Typical, 30pSec Maximum
RMS Phase Jitter (Fj = 637kHz to 10MHz; Random)	1.6pSec Typical
RMS Phase Jitter (Fj = 1MHz to 20MHz; Random)	0.7pSec Typical
RMS Phase Jitter (Fj = 1.875MHz to 20MHz; Random)	0.6pSec Typical
Start Up Time	10mSec Maximum
Storage Temperature Range	-55°C to +125°C

## ENVIRONMENTAL & MECHANICAL SPECIFICATIONS

ESD Susceptibility	MIL-STD-883, Method 3015, Class 2, HBM 2000V
Flammability	UL94-V0
Mechanical Shock	MIL-STD-883, Method 2002, Condition G, 30,000G
Moisture Resistance	MIL-STD-883, Method 1004
Moisture Sensitivity Level	J-STD-020, MSL 1

**EMDS22J2H-160.000M TR** [Click part number to visit Part Number Details page](#)**ENVIRONMENTAL & MECHANICAL SPECIFICATIONS CONTINUED**

<b>Resistance to Soldering Heat</b>	MIL-STD-202, Method 210, Condition K
<b>Resistance to Solvents</b>	MIL-STD-202, Method 215
<b>Solderability</b>	MIL-STD-883, Method 2003 (Pads on bottom of package only)
<b>Temperature Cycling</b>	MIL-STD-883, Method 1010, Condition B
<b>Thermal Shock</b>	MIL-STD-883, Method 1011, Condition B
<b>Vibration</b>	MIL-STD-883, Method 2007, Condition A, 20G

## EMDS22J2H-160.000M TR [Click part number to visit Part Number Details page](#)

### MECHANICAL DIMENSIONS (all dimensions in millimeters)

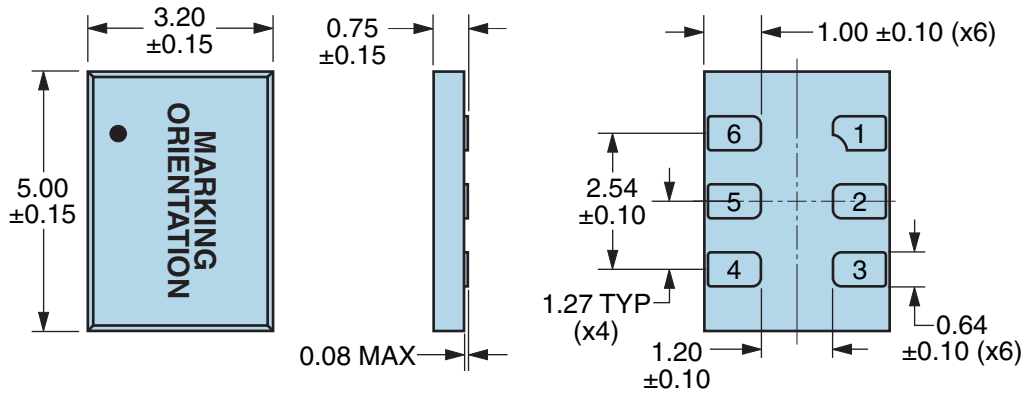

PIN	CONNECTION
1	Output Enable (OE)
2	No Connect
3	Case Ground
4	Output
5	Complementary Output
6	Supply Voltage

LINE	MARKING
1	<b>XXXX or XXXXX</b> XXXX or XXXXX=Ecliptek Manufacturing Identifier

### Suggested Solder Pad Layout

All Dimensions in Millimeters

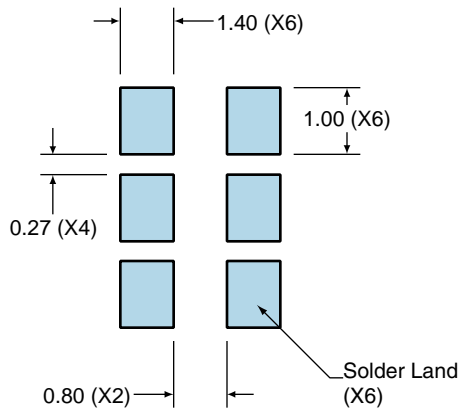

All Tolerances are  $\pm 0.1$

# EMDS22J2H-160.000M TR [Click part number to visit Part Number Details page](#)

## OUTPUT WAVEFORM & TIMING DIAGRAM

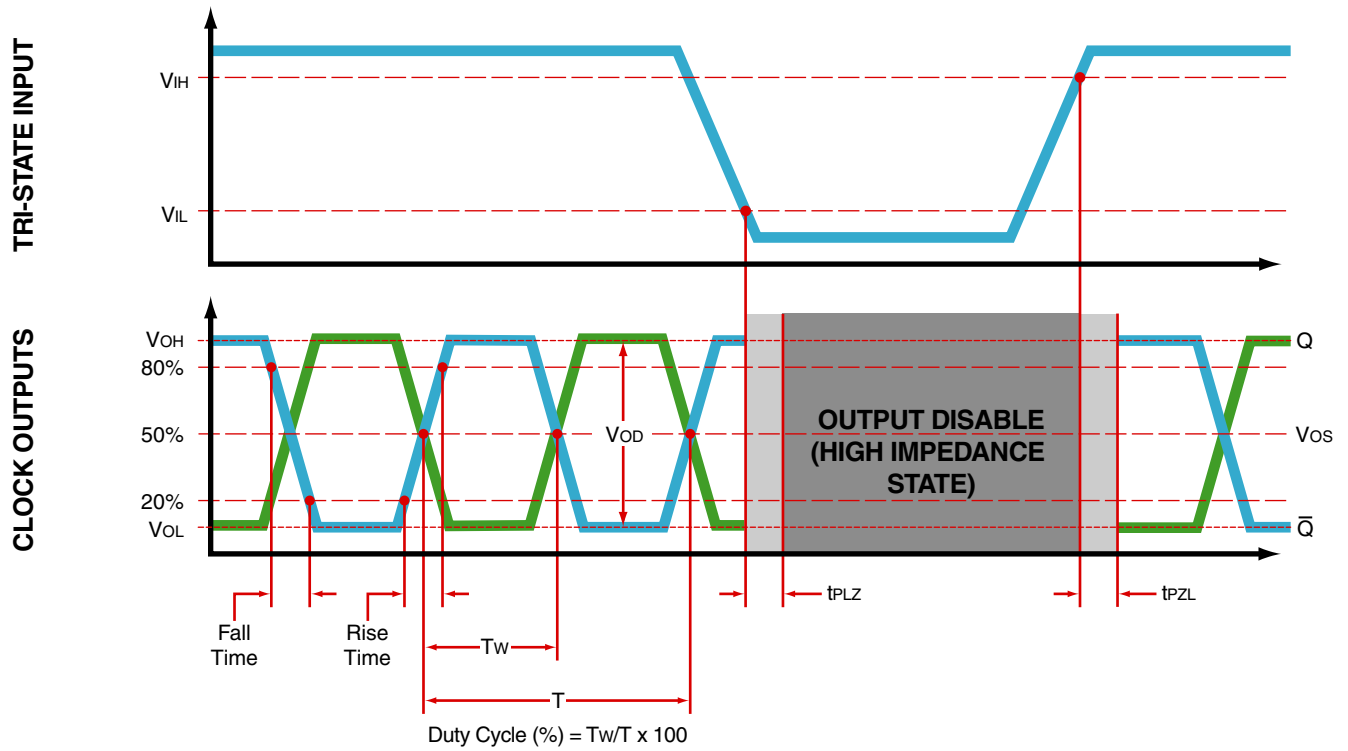

# EMDS22J2H-160.000M TR [Click part number to visit Part Number Details page](#)

## Test Circuit for Output Enable and Complementary Output

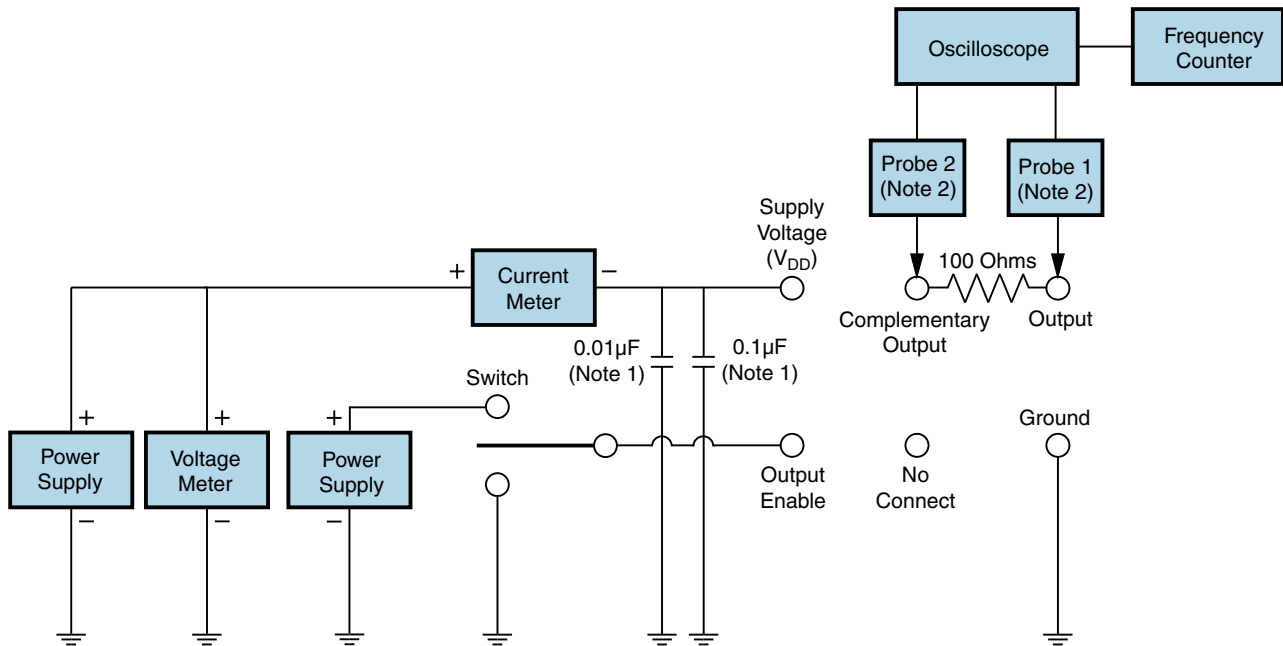

Note 1: An external  $0.01\mu\text{F}$  ceramic bypass capacitor in parallel with a  $0.1\mu\text{F}$  high frequency ceramic bypass capacitor close (less than 2mm) to the package ground and supply voltage pin is required.

Note 2: A low capacitance ( $<12\text{pF}$ ), 10X attenuation factor, high impedance ( $>10\text{Mohms}$ ), and high bandwidth ( $>500\text{MHz}$ ) passive probe is recommended.

Note 3: Test circuit PCB traces need to be designed for a characteristic line impedance of 50 ohms.

# EMDS22J2H-160.000M TR

## Tape & Reel Dimensions

Quantity Per Reel: 1,000 units

All Dimensions in Millimeters

Compliant to EIA-481

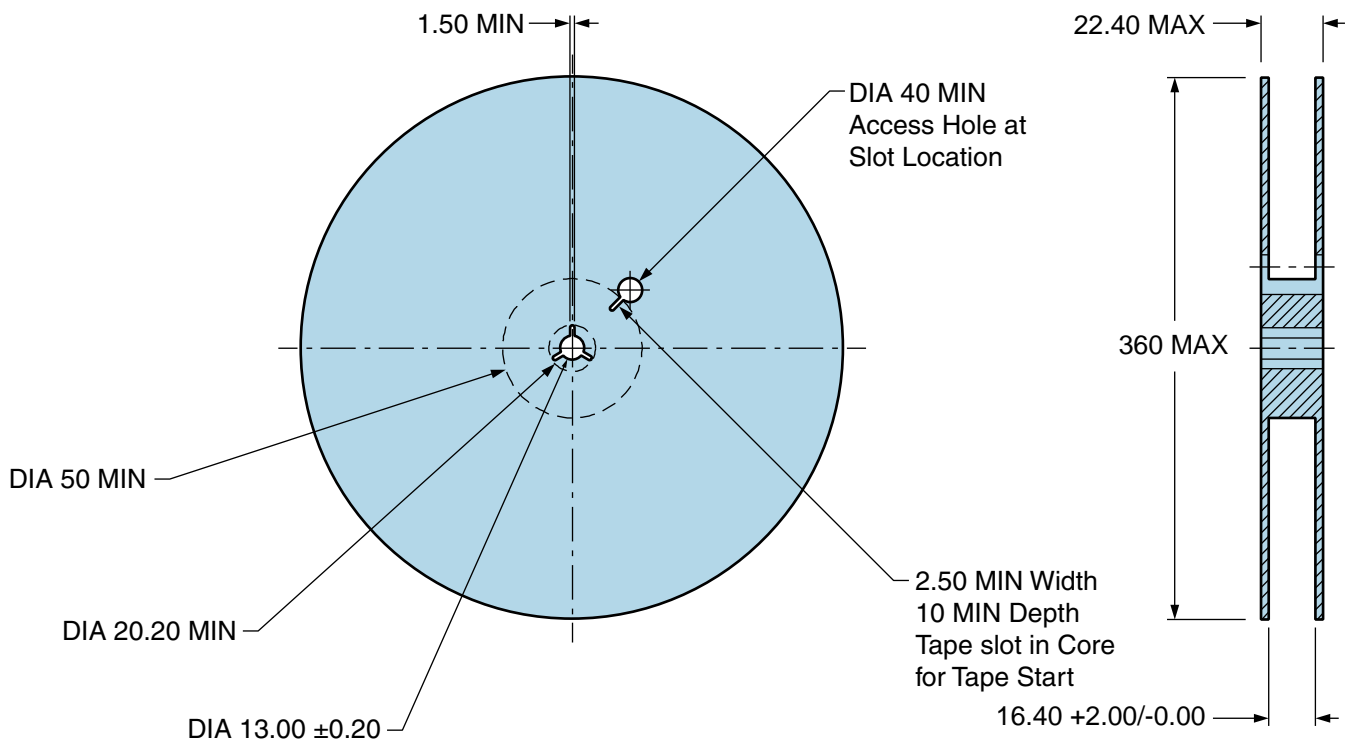
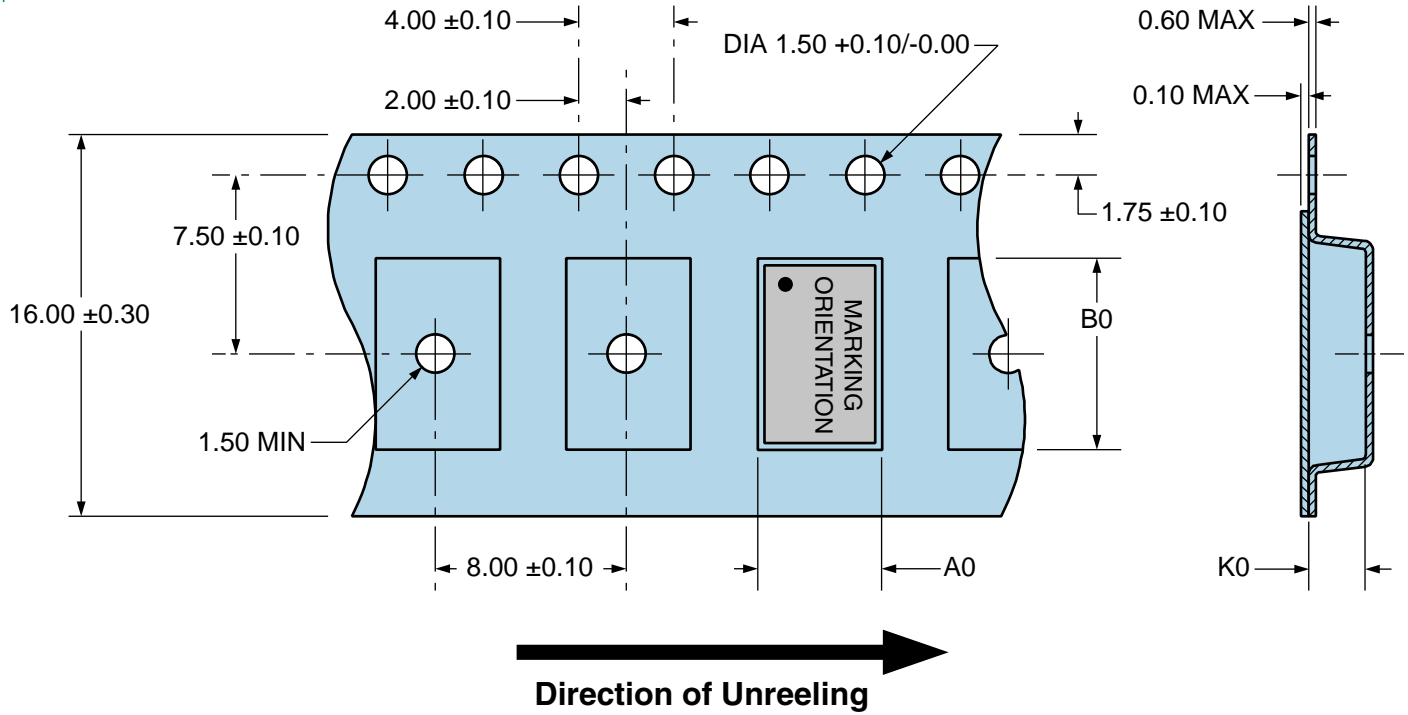

# EMDS22J2H-160.000M TR [Click part number to visit Part Number Details page](#)

## Recommended Solder Reflow Methods



### High Temperature Infrared/Convection

$T_s \text{ MAX to } T_L$ (Ramp-up Rate)	3°C/Second Maximum
--	--------------------

#### Preheat

- Temperature Minimum ( $T_s \text{ MIN}$ )	150°C
- Temperature Typical ( $T_s \text{ TYP}$ )	175°C
- Temperature Maximum ( $T_s \text{ MAX}$ )	200°C
- Time ( $t_s \text{ MIN}$ )	60 - 180 Seconds

Ramp-up Rate ( $T_L$ to $T_p$ )	3°C/Second Maximum
---------------------------------	--------------------

#### Time Maintained Above:

- Temperature ( $T_L$ )	217°C
- Time ( $t_L$ )	60 - 150 Seconds

Peak Temperature ( $T_p$ )	260°C Maximum for 10 Seconds Maximum
----------------------------	--------------------------------------

Target Peak Temperature ( $T_p \text{ Target}$ )	250°C +0/-5°C
--	---------------

Time within 5°C of actual peak ( $t_p$ )	20 - 40 Seconds
--	-----------------

Ramp-down Rate	6°C/Second Maximum
----------------	--------------------

Time 25°C to Peak Temperature (t)	8 Minutes Maximum
-----------------------------------	-------------------

Moisture Sensitivity Level	Level 1
----------------------------	---------

# EMDS22J2H-160.000M TR [Click part number to visit Part Number Details page](#)

## Recommended Solder Reflow Methods



### Low Temperature Infrared/Convection 240°C

Ts MAX to TL (Ramp-up Rate)	5°C/Second Maximum
<b>Preheat</b>	
- Temperature Minimum (Ts MIN)	N/A
- Temperature Typical (Ts TYP)	150°C
- Temperature Maximum (Ts MAX)	N/A
- Time (ts MIN)	60 - 120 Seconds
<b>Ramp-up Rate (TL to TP)</b>	5°C/Second Maximum
<b>Time Maintained Above:</b>	
- Temperature (TL)	150°C
- Time (tL)	200 Seconds Maximum
<b>Peak Temperature (TP)</b>	240°C Maximum
<b>Target Peak Temperature (TP Target)</b>	240°C Maximum 2 Times / 230°C Maximum 1 Time
<b>Time within 5°C of actual peak (tp)</b>	10 Seconds Maximum 2 Times / 80 Seconds Maximum 1 Time
<b>Ramp-down Rate</b>	5°C/Second Maximum
<b>Time 25°C to Peak Temperature (t)</b>	N/A
<b>Moisture Sensitivity Level</b>	Level 1

### Low Temperature Manual Soldering

185°C Maximum for 10 Seconds Maximum, 2 times Maximum.

### High Temperature Manual Soldering

260°C Maximum for 5 Seconds Maximum, 2 times Maximum.