

INCH-POUND

MS3476F
4 June 2009
SUPERSEDING
MS3476E
31 October 1988

DETAIL SPECIFICATION SHEET

CONNECTORS, PLUG, ELECTRICAL, SERIES 2,
CRIMP TYPE, BAYONET COUPLING, CLASSES A, D, L, T, W AND Z

Reactivated after 4 June 2009, and may be used
for new or existing designs and acquisitions.

This specification is approved for use by all Departments
and Agencies of the Department of Defense.

The requirements for acquiring the product described herein
shall consist of this specification sheet and MIL-DTL-26482.

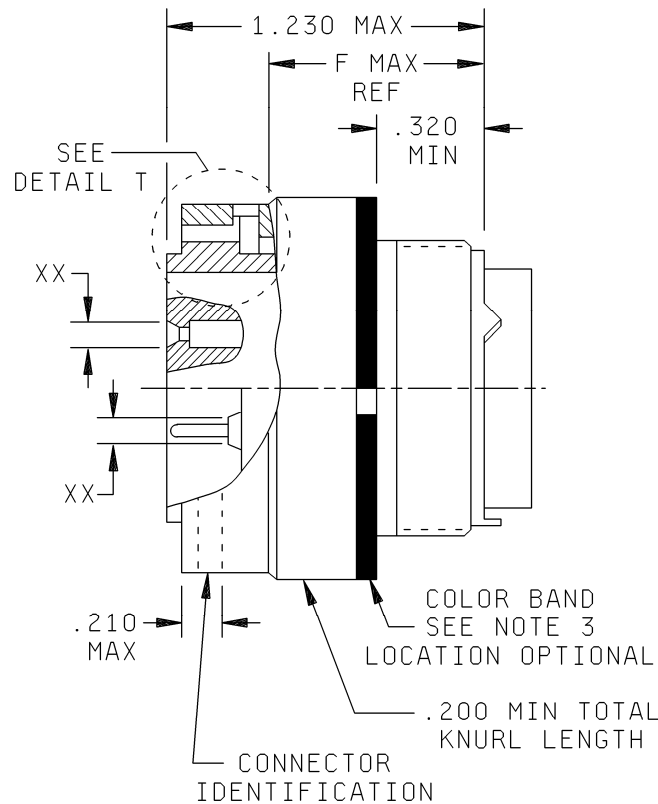

NOTE: For "XX", note 5 and table I for contact cavities requiring reduced dimensions.

FIGURE 1. Plug, dimensions.

AMSC N/A

FSC 5935

MS3476F

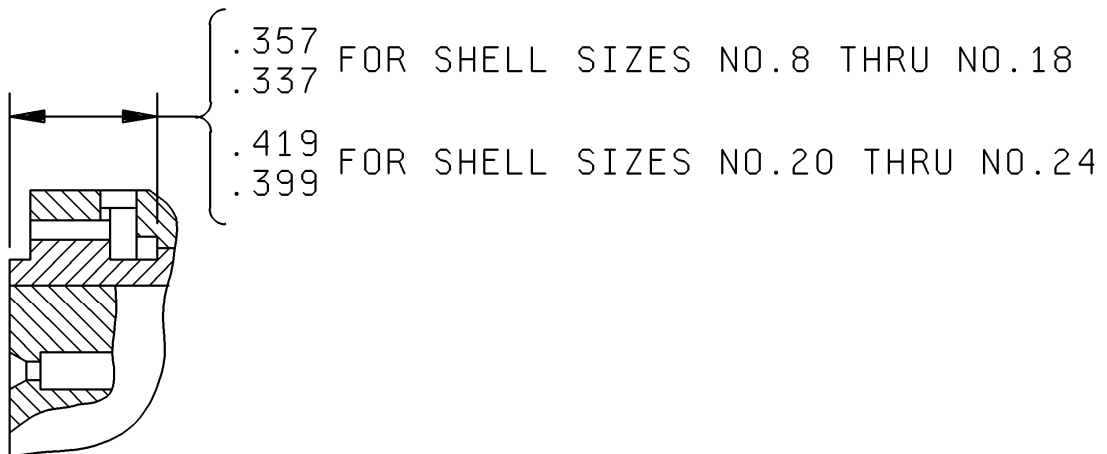
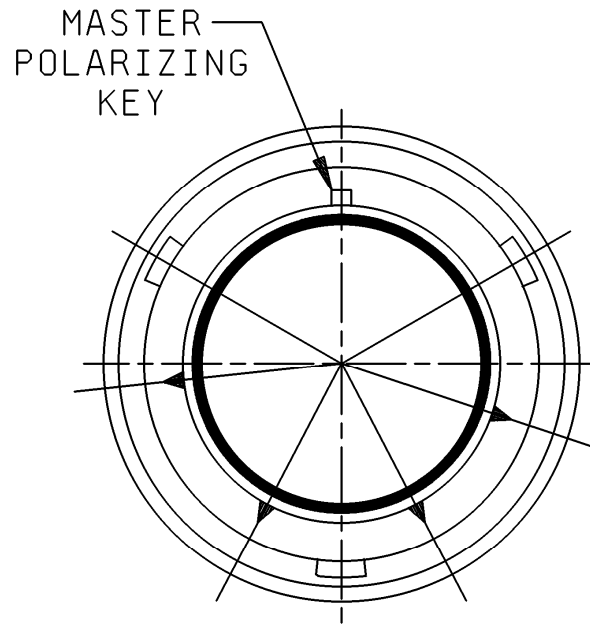
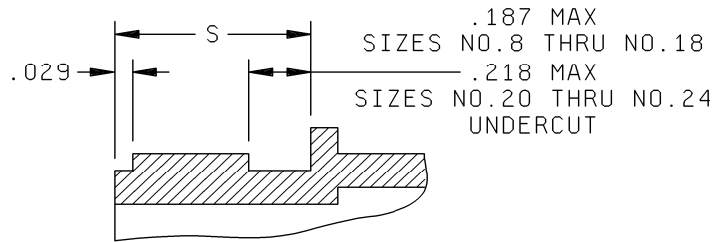
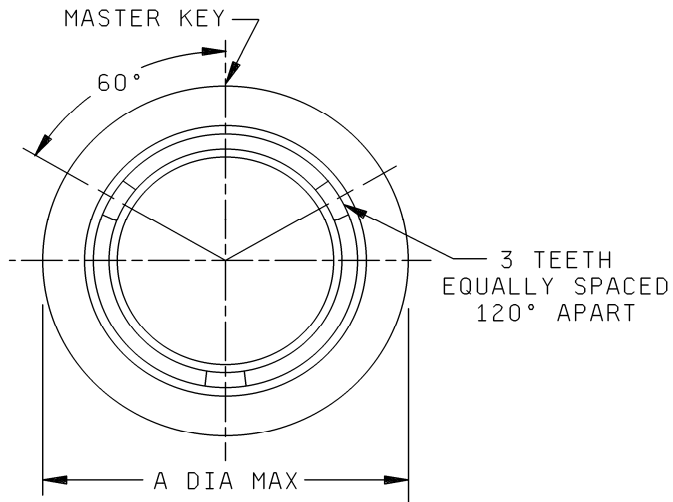

FIGURE 1. Plug, dimensions - Continued.

MS3476F



DETAIL T

COUPLING RING REMOVED
FOR CLARITY

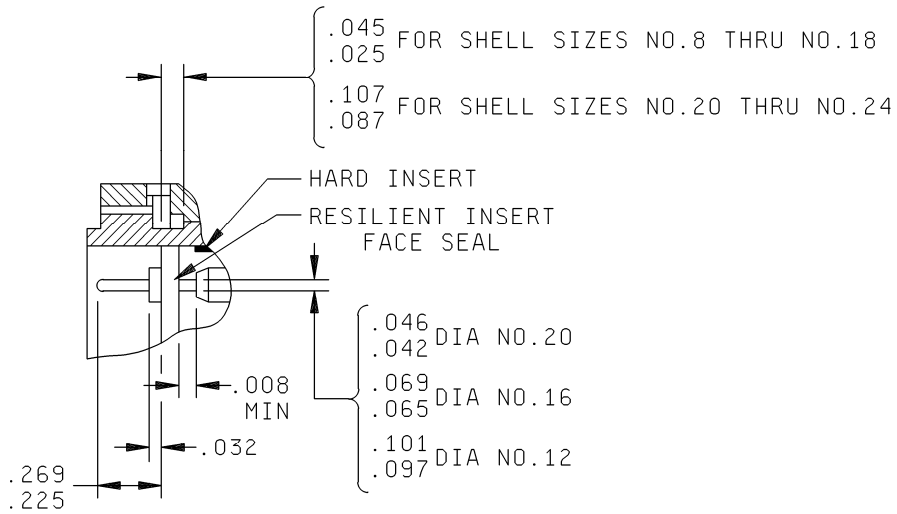

FIGURE 1. Plug dimensions - Continued.

MS3476F

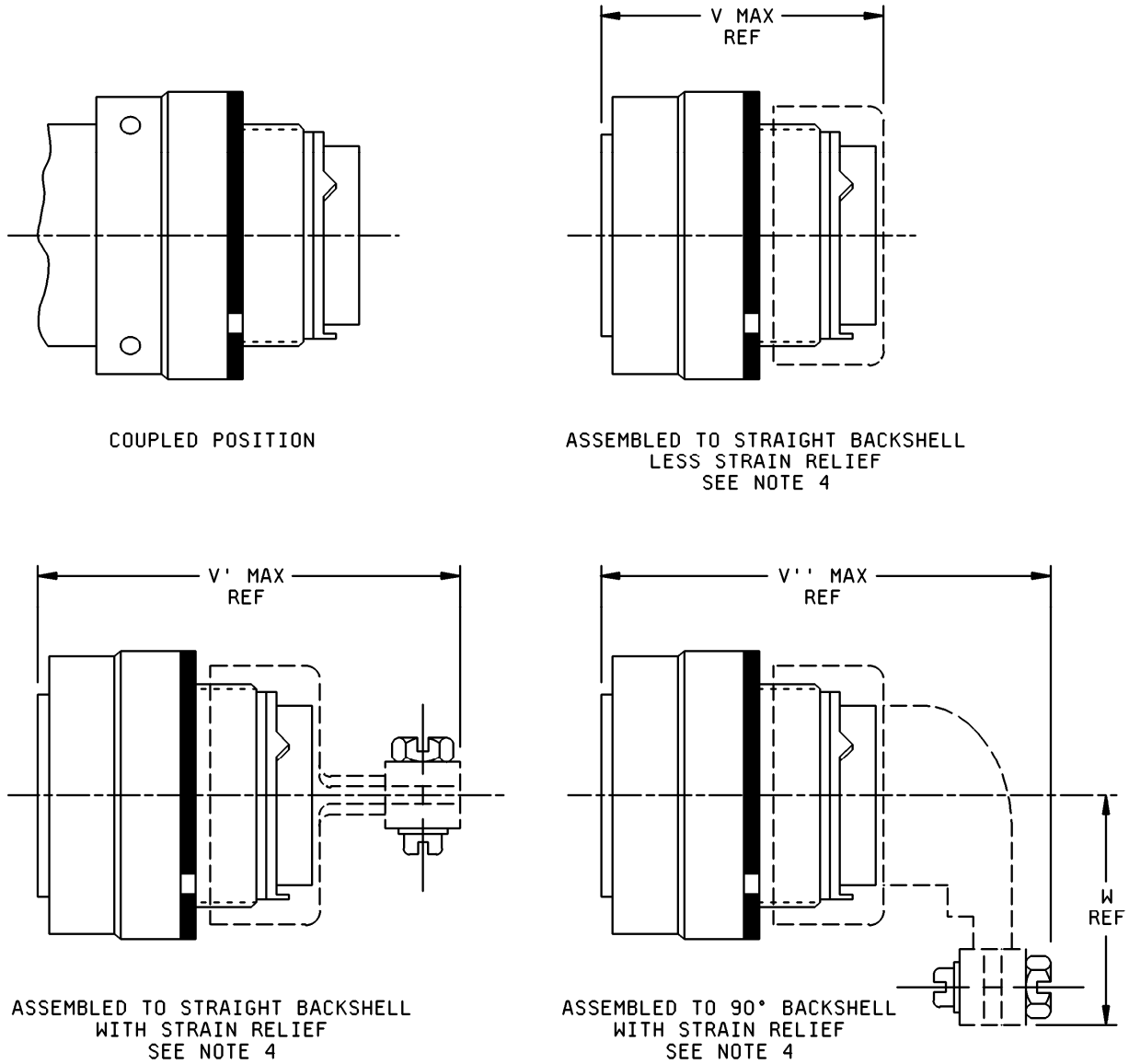

FIGURE 1. Plug dimensions - Continued.

MS3476F

Shell size	A	F	S	V	V'	V''	W	Max weight In lbs. (grams) 1/			
								Pin	Socket		
8	.782 (19.86)	.887 (22.53)	.363 (9.22)	1.507 (38.28)	1.857 (47.17)	2.130 (54.10)	.830 (21.08)	.0204 (9.26)	.0216 (9.81)		
10	.926 (23.52)						.880 (22.35)	.0406 (18.43)	.0421 (19.11)		
12	1.043 (26.49)						.950 (24.13)	.0505 (22.93)	.0536 (24.33)		
14	1.183 (30.05)						2.355 (59.82)	1.010 (25.65)	.0639 (29.01)	.0692 (31.42)	
16	1.305 (33.15)						2.490 (63.25)	1.070 (27.18)	.0788 (35.77)	.0880 (39.95)	
18	1.391 (35.33)						2.589 (65.76)	1.130 (28.70)	.0864 (39.22)	.0957 (43.44)	
20	1.531 (38.89)	.825 (20.96)	.425 (10.80)		2.092 (53.14)	2.722 (69.14)	1.190 (30.23)	.1016 (46.12)	.1114 (50.57)		
22	1.656 (42.06)							2.845 (72.26)	1.260 (32.00)	.1241 (56.34)	.1363 (61.88)
24	1.777 (45.14)							2.967 (75.36)	1.320 (33.53)	.1400 (63.56)	.1916 (86.98)

1/ Less contacts and accessories. Maximum weights do not apply to class S.

Inches	mm	Inches	mm	Inches	mm
.008	0.20	.065	1.66	.225	5.72
.010	0.25	.069	1.75	.269	6.83
.025	0.64	.087	2.21	.320	8.13
.029	0.74	.097	2.46	.337	8.56
.032	0.81	.101	2.57	.357	9.07
.042	1.07	.141	2.72	.399	10.13
.045	1.14	.200	5.08	.419	10.64
.046	1.17	.210	5.33	1.230	31.24

NOTES:

1. Dimensions are in inches. Metric equivalents are given for information only and are in parentheses.
2. Unless otherwise specified, tolerances are $\pm .005$ (0.13 mm) for 3 place decimals, $\pm .01$ (0.3 mm) for 2 place decimals, and $\pm 1^\circ$ for all angles.
3. Color bands: $0.070 \pm .031$ (1.78 ± 0.79 mm) wide, color blue.
4. Connector assembly must be used with a backshell. Backshells must be procured separately. See SAE-AS85049 for applicable backshells.
5. Insert arrangements requiring reduced diameters for raised seal barrier on outer row of contact cavities as indicated.

FIGURE 1. Plug, dimensions - Continued.

MS3476F

TABLE I. Contact cavities requiring reduced diameters (XX) for pins and sockets in outer row of contact cavities. 1/

Shell size	Insert arrangement	Contact Cavities
8	-33 & -98	A, B, C
12	-10	C, G
14	-12	A, B, C, D, E, F, G, H
14	-18	A, C, E, G, J, L
14	-19	B, D, F, H, K, M
16	-26	A, B, C, D, E, F, G, H, J, K, L, M, N, P, R
18	-32	A, B, C, D, E, F, G, H, J, K, L, M, N, P, R, S, T
22	-41	A, B, C, D, E, F, G, H, J, K, L, M, N, P, R, S, T, U, V, W, X, Y

1/ The reduced diameter "XX" refers to the diameters of the raised seal barriers (pin barrier rings) or lead-in chamfers (socket entry holes) to ensure proper sealing of pin and socket after mating. See MIL-DTL-26482, connector intermateability control dimensions (series 1 and series 2) figure for reduced diameter "XX" for contact size 20 only.

REQUIREMENTS:

Dimensions and configuration: See figure 1 and table I.

Connector mating: This connector mates with MS3470, MS3471, MS3472, MS3473, MS3474, MS3477 and MS3479.

Also, they will mate with MS3115 (dummy stowage receptacle) and with the following series 1 receptacles, provided both mating connectors contain a full compliment of power contacts: MS3100, MS3112, MS3113, MS3114, MS3119, MS3120, MS3122, MS3124, MS3127 and MS3128.

Intermateability and rear accessory interchangeability dimensions are in accordance with MIL-DTL-26482.

Class E is cancelled and replaced by class L.

This specification sheet supersedes, MIL-C-83723/13 and MIL-C-83723/14.

For insert arrangement, see MIL-STD-1669.

Insert arrangements requiring reduced diameters for raised seal barriers or lead-in chamfer on outer row of contact cavities as indicated, see table I.

Connector identification marking shall be in accordance with MIL-DTL-26482. Example: MS3476L----, minimum height does not apply to shell sizes 8, 10 and 12.

Part or Identifying Number (PIN) example:

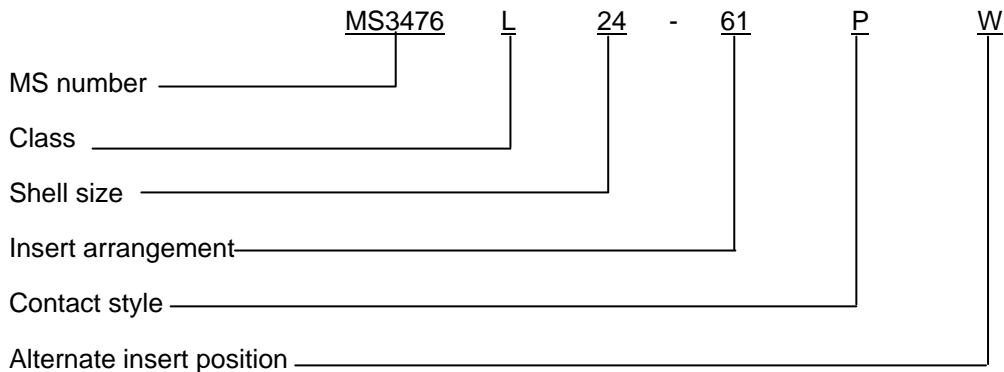

MS3476F

Changes from previous issue. Marginal notations are not used in this revision to identify changes with respect to the previous issue due to the extent of the changes.

Referenced documents. In addition to MIL-DTL-26482, this document references the following:

MS3100
MS3112
MS3113
MS3114
MS3115
MS3119
MS3120
MS3122
MS3124
MS3127
MS3128
MS3470
MS3471
MS3472
MS3473
MS3474
MS3477
MS3479
MIL-STD-1669
SAE-AS85049

CONCLUDING MATERIAL

Custodians:

Army – CR
Navy – AS
Air Force – 85
DLA – CC

Preparing activity:
DLA – CC

(Project: 5935–2007-188)

Review activities:

Army – AR, AV
Navy – EC, SH
Air Force – 99

NOTE: The activities listed above were interested in this document as of the date of this document. Since organizations and responsibilities can change, you should verify the currency of the information above using the ASSIST Online database at <http://assist.daps.dla.mil>.