

1

2

3

4

A

B

C

D

A

B

C

D

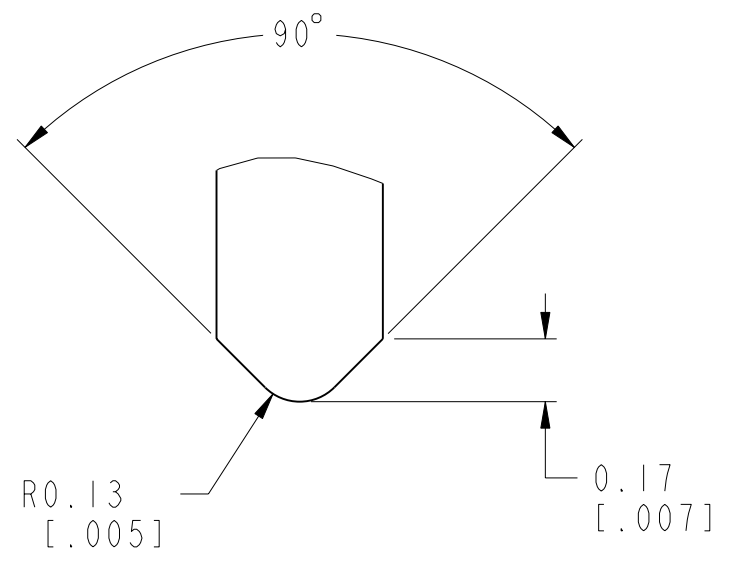
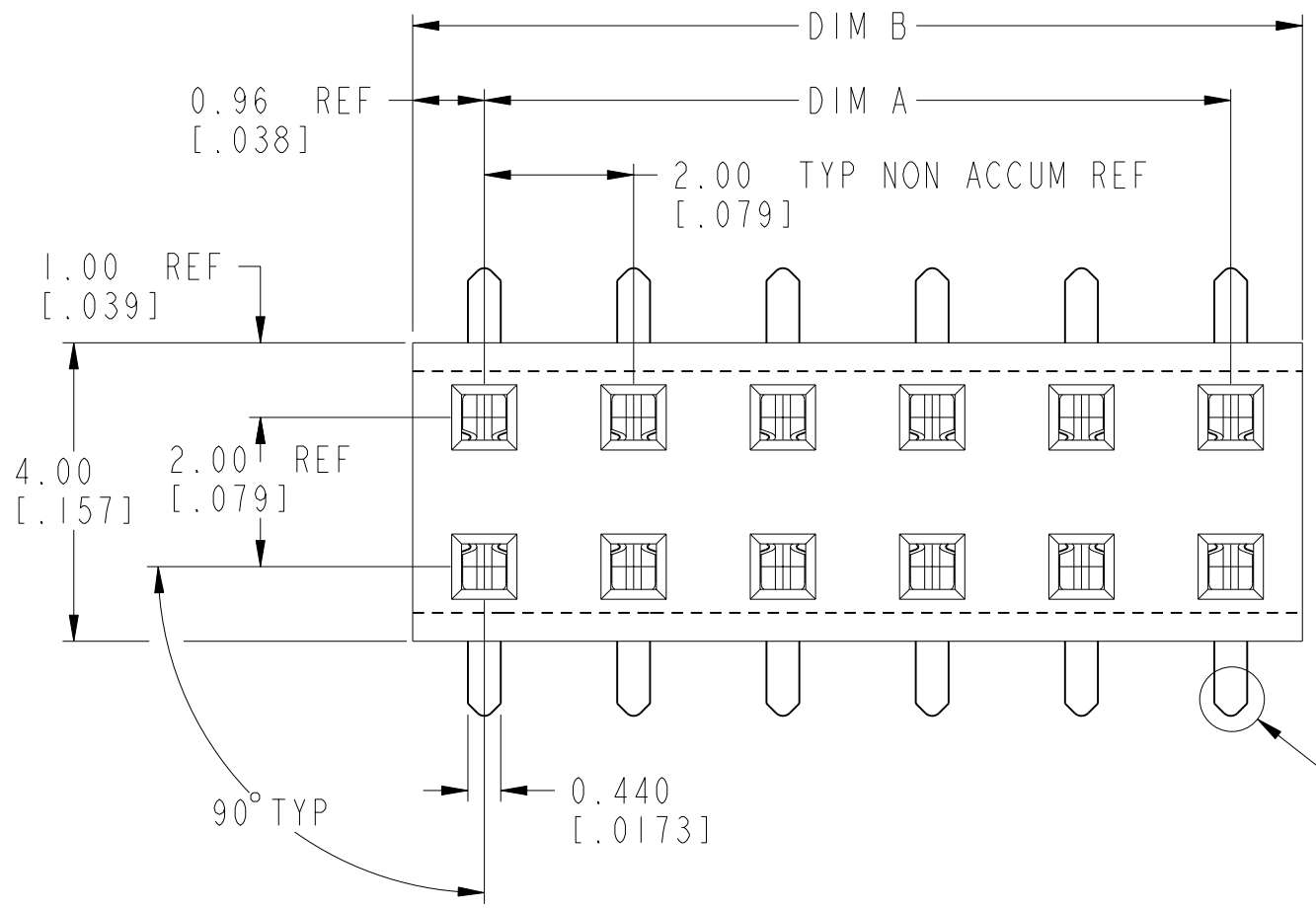

DETAIL A
SCALE 50:1

DETAIL A
SEE NOTE 4

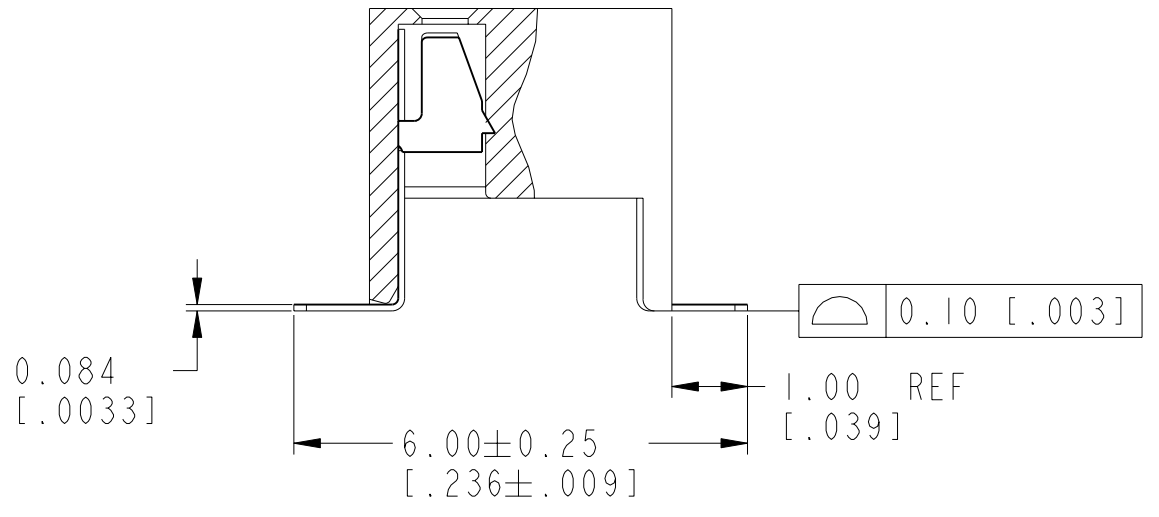
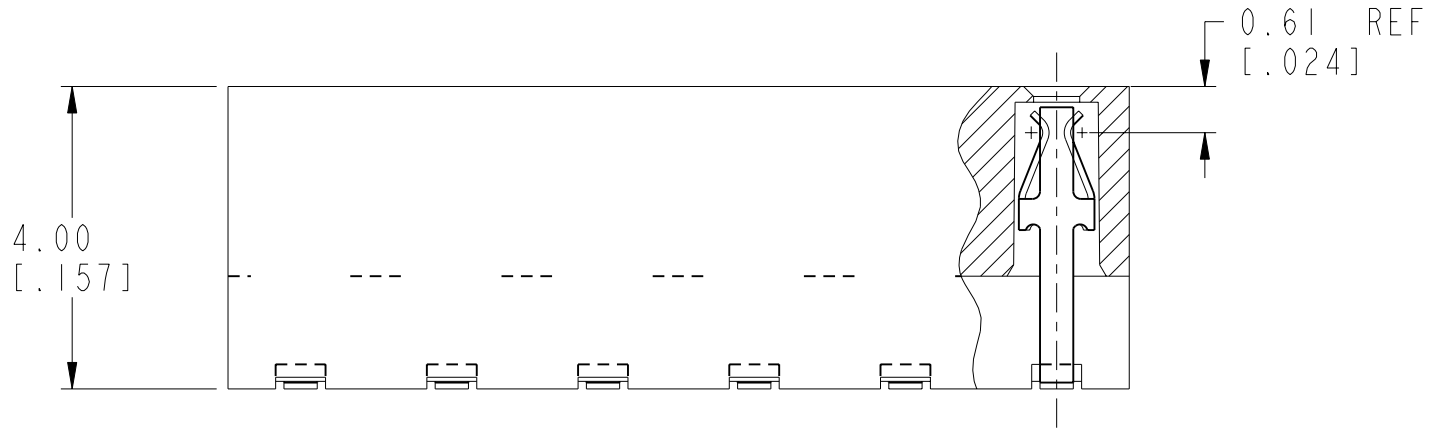

Copyright FCI.

CONFIDENTIAL

www.fciconnect.com		surface - ✓ ISO 1302	tolerance std ISO 406 ISO 1101	projection MM/INCH
		TOLERANCES UNLESS OTHERWISE SPECIFIED		size A3
Dr	BS LOW	2000-01-06	ANGULAR	x.X/.XX ±0.3/.01
Eng	BS LOW	2000-01-06	LINEAR	x.XX/.XXX ±0.13/.005
Chr	KH LEE	2010-06-28	0° ±2°	x.XXX/.XXXX ±0.051/.0020
Appr	JOEY NG	2010-06-28	Product family	LPVCC
FCI		LOW PROFILE VCC		91812
		TOP ENTRY SMT 4.00 ASSY		P
catalog no		CUSTOMER		sheet 1 of 3

rev	ecn no	dr	date
K	S40318	BSL	1994-12-20
L	S80115	BSL	1998-05-14
M	V94400	BSL	1999-12-01
N	S05-0064	KBM	2005-03-01
P	S10-0136	NBR	2010-06-28
-	-	-	-
-	-	-	-

PRODUCT NO.	POSITIONS	DIM. A	DIM. B
91812-X04	2 X 2	2.00 / .079	3.92 / .154
-X06	2 X 3	4.00 / .158	5.92 / .233
-X08	2 X 4	6.00 / .236	7.92 / .312
-X10	2 X 5	8.00 / .315	9.92 / .391
-X12	2 X 6	10.00 / .394	11.92 / .469
-X14	2 X 7	12.00 / .472	13.92 / .548
-X16	2 X 8	14.00 / .551	15.92 / .627
-X18	2 X 9	16.00 / .630	17.92 / .706
-X20	2 X 10	18.00 / .709	19.92 / .784
-X22	2 X 11	20.00 / .787	21.92 / .863
-X24	2 X 12	22.00 / .866	23.92 / .942
-X26	2 X 13	24.00 / .945	25.92 / 1.020
-X28	2 X 14	26.00 / 1.024	27.92 / 1.099
-X30	2 X 15	28.00 / 1.102	29.92 / 1.178

PLATING OPTIONS OVER CONTACT AREA
0 = 0.20μm/8μ" Au
1 = 0.76μm/30μ" Au
3 = 0.38μm/15μ" Au

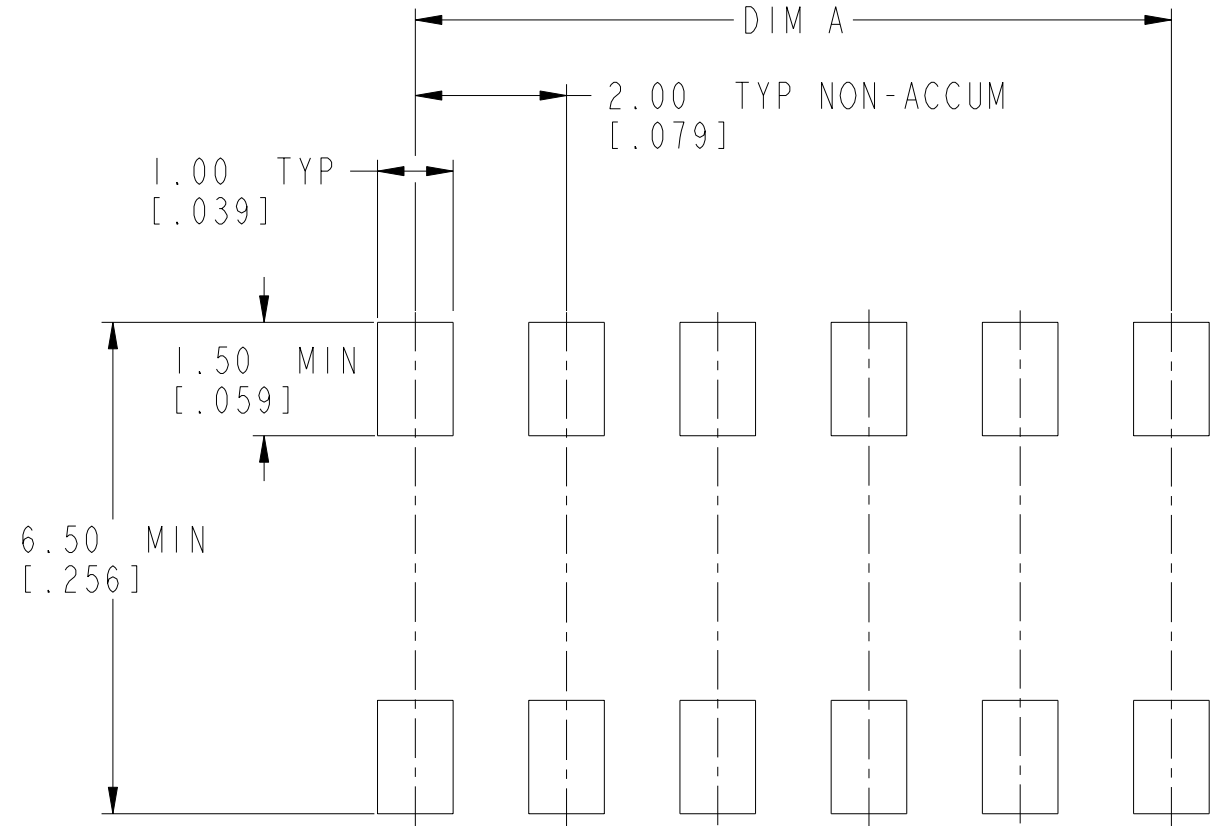

RECOMMENDED PAD LAYOUT

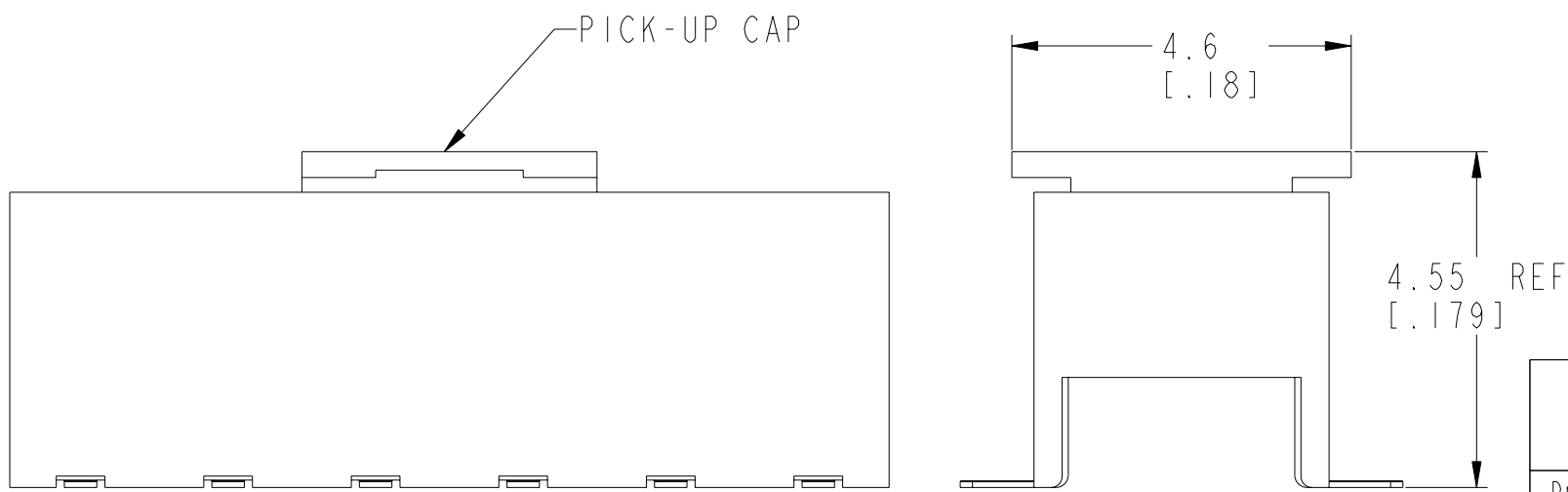

FIG. 1
NOTE 7 (b) & (d)

CONFIDENTIAL

www.fciconnect.com			surface - ✓ ISO 1302	tolerance std ISO 406 ISO 1101	projection MM/INCH
			TOLERANCES UNLESS OTHERWISE SPECIFIED		size A3
Dr	BS LOW	2000-01-06	ANGULAR	x.xx/.xx	±0.3/.01
Eng	BS LOW	2000-01-06	LINEAR	x.xx/.xxx	±0.13/.005
Chr	KH LEE	2010-06-28	0° ±2°	x.xxx/.xxxx	±0.051/.0020
Appr	JOEY NG	2010-06-28	Product family	LPVCC	Spec ref -
FCi			Title LOW PROFILE VCC		Rev. P
			TOP ENTRY SMT 4.00 ASSY		dwg no 91812
catalog no -			CUSTOMER		sheet 2 of 3

NOTES:

- 1. HOUSING MATERIAL : HIGH TEMP PLASTIC.
- 2. TERMINAL MATERIAL : BeCu.
- 3. TERMINAL RETENTION 0.5Kg/1.1 Lbs.
- 4. "V" CUT OPTIONAL - MANUFACTURING PROCESS OPTION.
- 5. SOLDER TAILS PLATING:
 (a) SOLDER TAIL OF P/N:91812-XXX IS TIN/LEAD PLATED.
 (b) SOLDER TAIL OF P/N:91812-XXXLF IS GOLD FLASH PLATED.

6. PRODUCT DESCRIPTION CODE :

XXXXX-XXXLF

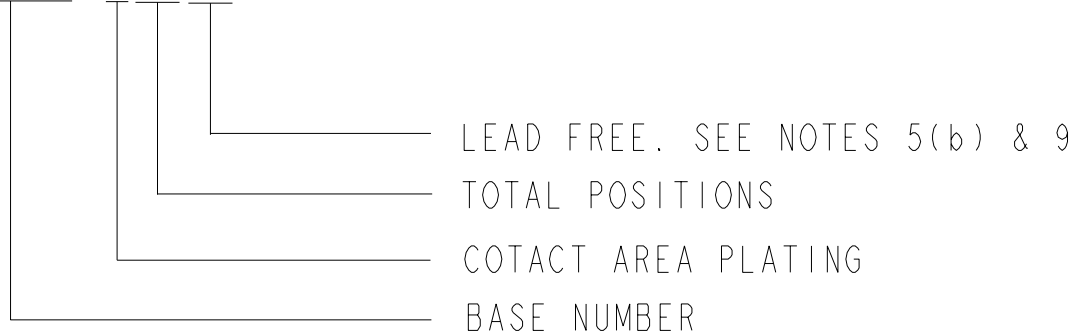

- 7. PACKAGING:
 (a) XXXXX-XXX --- STD PACKAGING IN TUBE.
 (b) XXXXX-XXXTR --- TAPE AND REEL (CONDUCTIVE) PACKAGING WITH PICK-UP CAP (SEE FIG 1).
 (c) XXXXX-XXXTRN --- TAPE AND REEL (CONDUCTIVE) PACKAGING WITHOUT PICK-UP CAP.
 (d) XXXXX-XXXCR --- TAPE AND REEL (NON-CONDUCTIVE) PACKAGING WITH PICK-UP CAP (SEE FIG 1).
 (e) XXXXX-XXXCRN --- TAPE AND REEL (NON-CONDUCTIVE) PACKAGING WITHOUT PICK-UP CAP.

8. THE HOUSING WILL WITHSTAND EXPOSURE TO 255°C PEAK TEMPERATURE FOR 10 SECONDS IN A CONVECTION, INFRA-RED OR VAPOR PHASE REFLOW OVEN.

9. THIS PRODUCT MEETS EUROPEAN UNION DIRECTIVES AND OTHER COUNTRY REGULATIONS AS DESCRIBED IN GS-22-008.

10. A P SYMBOL WILL BE NEXT TO ANY DIMENSION, VIEW OR NOTE WHICH HAS BEEN MODIFIED WITH THE CURRENT DRAWING REVISION.

CONFIDENTIAL

www.fciconnect.com			surface - ✓ ISO 1302	tolerance std ISO 406 ISO 1101	projection MM / INCH	TOLERANCES UNLESS OTHERWISE SPECIFIED		
Dr	BS LOW	2000-01-06	ANGULAR	LINEAR	x.X/.XX	±0.3/.01	size A3	Scale 10:1
Eng	BS LOW	2000-01-06			x.XX/.XXX	±0.13/.005	ECN S10-0136	
Chr	KH LEE	2010-06-28	0° ±2°		x.XXX/.XXXX	±0.051/.0020	Spec ref -	
Appr	JOEY NG	2010-06-28	Product family LPVCC					
			title LOW PROFILE VCC TOP ENTRY SMT 4.00 ASSY		dwg no 91812		Rev. P	
catalog no -			CUSTOMER		sheet 3 of 3			